

- MATERIALS:**
1. CORPORATION STOP: MUELLER MODEL B-2969-N;
  2. CURB BOX: BINGHAM AND TAYLOR CO., FIGURE 4901, SIZE NO. 94-E, COMPLETE WITH LID;
  3. CURB STOP: MUELLER MODEL B-25209N ;
  4. STATIONARY ROD: MANUFACTURER'S STANDARD;
  5. FOR 1-1/2" AND 2" SERVICES, PROVIDE SMITH-BLAIR TYPE 317 SERVICE SADDLE
  6. OR EQUALS

- NOTES:**
1. BACKFILL TRENCH PER SPECIFICATIONS.
  2. COMPACT BACKFILL AS PER SPECIFICATIONS.

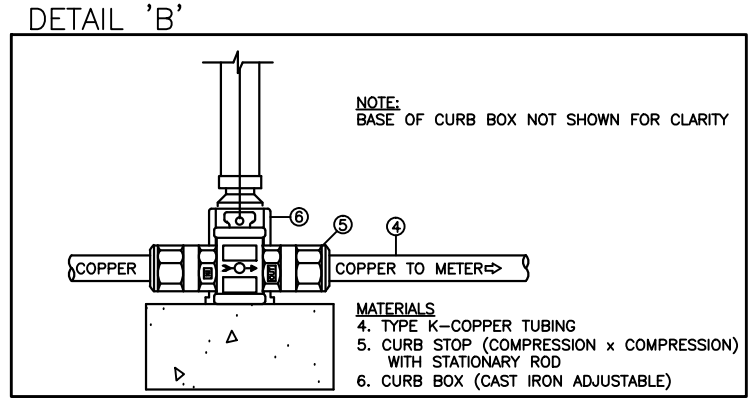
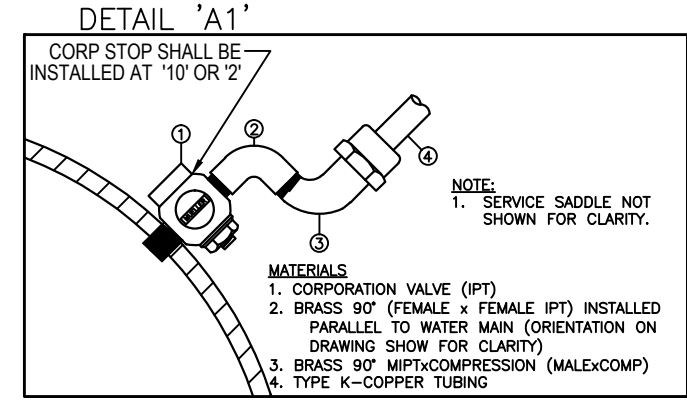

# WATER SERVICE CONNECTION DETAIL

(NOT TO SCALE)

<b>PASSAIC VALLEY WATER COMMISSION</b>		
1525 MAIN AVE. CLIFTON, N.J. TEL:(973) 340-4300		
<b>WATER SERVICE CONNECTION UP TO 2"</b>		
<b>TYPICAL DETAIL</b>		
DESIGNED BY:		DATE: 3/28/22
DRAWN BY: M.R/PAD		SCALE: NOT TO SCALE
CHECKED BY:		DWG. 1 OF 1