



PASSAIC VALLEY WATER COMMISSION

RESOLUTION #24-EXE-10

RESOLUTION OF PASSAIC VALLEY WATER COMMISSION

DATE OF ADOPTION: OCTOBER 23, 2024

Factual Contents certified to by Louis Amodio, Administrative Secretary. Approved as to Form and Legality on basis of facts set forth by Yaacov Brisman, General Counsel. Entering Executive Closed Session in accordance with Open Public Meetings Act, R.S. 10:4-6 et seq. Pursuant to the Open Public Meetings Act,

COMMISSIONER: **RUBY N. COTTON** offers the following Resolution for adoption:

WHEREAS, Section 8 of the Open Public Meetings Act, c. 231, P.L. 1975, permits the exclusion of the public from a meeting in certain circumstances; and

WHEREAS the public body is of the opinion that such circumstances presently exist:

NOW, THEREFORE, BE IT RESOLVED, by the Commissioners of Passaic Valley Water Commission:

1. The public shall be excluded from discussion of the hereinafter-specified subject Matters; Contracts, Security, Negotiations, Personnel, Law and: other matters as may be discussed *in camera*.
2. It is anticipated at this time that the above-stated subject matters will be ratified During public meeting following or as soon thereafter as the reason for discussion no Longer exists.
3. This Resolution shall take effect immediately.

Second by COMMISSIONER: **GERALD FRIEND** Time: 10:06 A.M.

RECORD OF COMMISSION VOTE ON FINAL PASSAGE

| | AYE | NAY | ABSTAIN | ABSENT |
|--------------------|----------|-----|---------|----------|
| VAN RENSA LIER, R. | ___ | ___ | ___ | <u>X</u> |
| COTTON, R. | <u>X</u> | ___ | ___ | ___ |
| SANCHEZ, R. | <u>X</u> | ___ | ___ | ___ |
| KOLODZIEJ, J. | <u>X</u> | ___ | ___ | ___ |
| FRIEND, G. | <u>X</u> | ___ | ___ | ___ |
| DEPADUA, C. | <u>X</u> | ___ | ___ | ___ |
| LEVINE, J. | <u>X</u> | ___ | ___ | ___ |

Adopted at a meeting of Passaic Valley Water Commission.

President
 JEFFREY LEVINE

Secretary
 RUBY N. COTTON

This Resolution, when adopted, must remain in the custody of the Administrative Secretary.

RESOLUTION NO. 24-116

PASSAIC VALLEY WATER COMMISSION

**RESOLUTION TO AWARD CONTRACT NO. 24-PA-06 ENTITLED
"PROFESSIONAL SERVICES FOR FINANCIAL ADVISOR"**

DATE OF ADOPTION: OCTOBER 23, 2024

Introduced by Commissioner: **RIGO SANCHEZ**

Seconded by Commissioner: **JOSEPH KOLODZIEJ**

WHEREAS, Passaic Valley Water Commission ("PVWC") has solicited for professional services (or Extraordinary Unspecifiable Services) for Award Project No. 24-PA-06, "Professional Services for Financial Advisor" (hereinafter the "Project"), with said solicitation and procurement of responses (and evaluation of same) undertaken through a Fair and Open process, as defined in N.J.S.A. 19:44A-20.7 (hereinafter the "Fair and Open Process"); and

WHEREAS, the Local Public Contracts Law, N.J.S.A. 40A:11-5(1)(a)(i) and the Fair and Open Process require that notice, with respect to contracts for professional services (or Extraordinary Unspecifiable Services), procured through a fair and open process and awarded without competitive bids, must be publicly advertised; and

WHEREAS, following public advertisement as required by New Jersey law, in accordance with an appropriate form of notice, and placement of the said notice on the official website of PVWC, as well as in the official newspaper of PVWC and any other such publications as may have been deemed appropriate, PVWC has received a response to provide professional services (or Extraordinary Unspecifiable Services) related to the Project from two (2) professional (or provider of Extraordinary Unspecifiable Services) providers; and

WHEREAS, the firm of NW Financial Group, LLC of Hoboken, New Jersey (the "Awardee") was determined to be professionally qualified and capable of performing the required services with respect to the Project, with

reimbursement to be on a Take-and-Pay, Time-and-Materials basis, not to exceed \$60,000 over a period of one (1) year, as stipulated by the Commission in the Form of Agreement for Professional Services (the "Contract"); and

WHEREAS, a copy of the Contract is attached hereto as **Exhibit A**; and

WHEREAS, it is in the best interest of PVWC, its users and constituent municipalities to engage, or continue to engage, the services of the Awardee at this time; and

WHEREAS, the services to be rendered pursuant hereto constitute professional services (or Extraordinary Unspecifiable Services) within the meaning and intent of the Local Public Contracts Law; and

WHEREAS, the Responses and solicitations are on file in the office of the Administrative Secretary and available for inspection; and

WHEREAS, PVWC's Chief Financial Officer has certified, with respect hereto, that funds are currently available for said purpose and a copy of the said certification is attached hereto and made a part hereof as **Exhibit B**.

WHEREAS, PVWC's Chief Financial Officer has certified, with respect hereto, that funds are currently available for said purpose and said certificate is on file in the Purchasing Department.

NOW, THEREFORE, BE IT RESOLVED, by Passaic Valley Water Commission, in the County of Passaic, New Jersey:

1. That PVWC hereby awards the Contract to the Awardees in accordance with N.J.S.A. 40A:11-1 et seq. and N.J.S.A. 19:44A-20.7, and in accordance with said Response, as set forth hereinabove; and
2. That an appropriate official of PVWC, on behalf of PVWC, is hereby authorized and directed to execute the Contract hereby awarded to the Awardee and the Secretary of PVWC to attest to the Contract and such other officers, employees and officials of PVWC are hereby authorized to perform such acts and execute such documents as are necessary to implement the terms and intentions of this Resolution, and

3. That this matter shall be advertised as required by New Jersey law, in accordance with an appropriate form of notice, and a copy of this Resolution and Agreement shall be placed on file and made available for inspection at the office of the Administrative Secretary of Passaic Valley Water Commission.

RECORD OF COMMISSION VOTE ON FINAL PASSAGE

| | AYE | NAY | ABSTAIN | ABSENT |
|---------------------------|--------------|------------|----------------|---------------|
| SANCHEZ, R. | <u> X </u> | ___ | ___ | ___ |
| COTTON, R. | <u> X </u> | ___ | ___ | ___ |
| DEPADUA, C. | <u> X </u> | ___ | ___ | ___ |
| KOLODZIEJ, J. | <u> X </u> | ___ | ___ | ___ |
| LEVINE, J. | <u> X </u> | ___ | ___ | ___ |
| VAN RENSA LIER, R. | ___ | ___ | ___ | <u> X </u> |
| FRIEND, G. | <u> X </u> | ___ | ___ | ___ |

Adopted at a meeting of Passaic Valley Water Commission.



President
JEFFREY LEVINE



Secretary
RUBY N. COTTON

This Resolution, when adopted, must remain in the custody of the Administrative Secretary.

CERTIFICATION

I, LOUIS AMODIO, Administrative Secretary of the Passaic Valley Water Commission in the County of Passaic, and the State of New Jersey do hereby certify that the foregoing Resolution is a true copy thereof of the foregoing Resolution duly passed and adopted by a majority of a legal quorum of the full membership of the Passaic Valley Water Commission at its duly noticed and convened meeting of the said Commission on October 23, 2024.

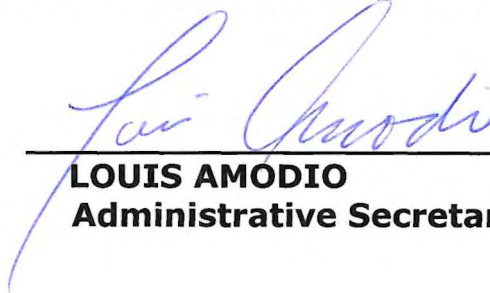

LOUIS AMODIO
Administrative Secretary

EXHIBIT A

PASSAIC VALLEY WATER COMMISSION

REQUEST FOR QUALIFICATIONS FOR PROFESSIONAL SERVICES (OR EXTRAORDINARY UNSPECIFIABLE SERVICES)

PVWC'S STANDARD FORM OF AGREEMENT FOR PROFESSIONAL SERVICES

APPENDIX C

THIS AGREEMENT (hereinafter "AGREEMENT") made as of _____, 20__ between PASSAIC VALLEY WATER COMMISSION ("PVWC"), a Public Utility Company organized pursuant to its enabling statute (N.J.S.A. 40:62-108 et seq.), having its principal place of business at 1525 Main Avenue, Clifton, New Jersey 07011, and NW Financial Group, LLC, a professional firm (hereinafter "PROFESSIONAL") having a place of business at 522 Broad Street, Bloomfield, NJ 07003.

WHEREAS, PVWC desires professional services as applicable, to assist PVWC in its efforts related to Project Number **24-PA-06** entitled "**PROFESSIONAL SERVICES FOR FINANCIAL ADVISER**"; and

WHEREAS, PVWC requires Professional Services to assist it in implementing the PROJECT; and:

WHEREAS, PROFESSIONAL represents that it has the experience and the required professional knowledge to provide the professional services, and/or extraordinary unspecifiable services, as applicable (hereinafter "PROFESSIONAL SERVICES"), and as required by PVWC in this regard as set forth in the "Public Notice", "Table of Contents", and the "Request for Qualifications" of the "Request for Qualifications for Professional Services (or Extraordinary Unspecifiable Services)", and Appendices A, B, C, D & E of the Solicitation (and including, where applicable, Appendix F with additional technical and other requirements attached thereto); all of which, along with a copy of the PROFESSIONAL'S Statement of Qualifications dated September 30, 2024, are collectively referred to herein as the "QUALIFICATIONS"; and

WHEREAS, the AGREEMENT shall be for up to a one-year period of time commencing on the Effective Date of this AGREEMENT as defined in Paragraph 19 herein, and for any extended periods authorized by PVWC.

WHEREAS, PVWC and PROFESSIONAL are desirous of entering into a consulting agreement to cover the PROFESSIONAL SERVICES authorized by PVWC and required for the PROJECT; and

NOW, THEREFORE, in consideration of the mutual promises herein, PVWC and PROFESSIONAL agree that the terms and conditions of this AGREEMENT are the following:

1. PROFESSIONAL shall provide the PROFESSIONAL SERVICES authorized by PVWC and required for the PROJECT. PROFESSIONAL'S obligations under this AGREEMENT are solely for the benefit of PVWC and no other party is intended to benefit or have rights hereunder.

2. PROFESSIONAL shall perform the PROFESSIONAL SERVICES as defined under this AGREEMENT at a level customary for competent and prudent professional service providers, all as applicable, performing such services at the time and place where the services are provided ("STANDARD OF CARE"). These services will be provided by professional service providers in the appropriate disciplines, and by other professionals and individuals skilled in other technical disciplines, as appropriate. PROFESSIONAL shall be responsible for the professional quality, technical

accuracy, timely completion and the coordination of all aspects of its services including reports and other deliverables and services provided under this AGREEMENT. The services to be performed by PROFESSIONAL shall conform to the generally accepted codes and regulations applicable to the subject PROJECT. PROFESSIONAL agrees to indemnify and hold PVWC harmless from all losses and damages resulting from PROFESSIONAL'S failure to meet the STANDARD OF CARE. Further, PROFESSIONAL shall correct and re-perform any services not conforming to the required STANDARD OF CARE without additional compensation and cost to PVWC, (including, but not limited to pending written or oral testimony, reports, etc., which might occur from activities resulting from the performance of this AGREEMENT which were caused by PROFESSIONAL'S performance). In addition, PROFESSIONAL shall indemnify and hold harmless PVWC and its officers, agents and employees of PVWC from and against any losses, claims, damages, or liabilities to which PVWC may become subject insofar as and to the extent they arise out of the deviation from the STANDARD OF CARE in the performance of the services by the PROFESSIONAL, hereunder.

3. The cost of services for those portions, if any, of the PROJECT that are pre-authorized in writing by the Commission (and subsequently performed by PROFESSIONAL pursuant to this AGREEMENT for PROJECT) shall be as stipulated in Appendix E or in accordance with the QUALIFICATIONS not to exceed \$60,000.00.

PROFESSIONAL shall invoice PVWC its services hereunder after completion thereof and on the basis of reports and accompanying documents, if appropriate, on a monthly basis, including therein information as to progress in performance as against one hundred percent (100%) completion thereof and also showing amounts previously compensated hereunder, as against the total authorization. To the extent items appearing on invoices presented by PROFESSIONAL are not contested, PVWC will remit payment of the invoice as soon as it can reasonably process same in the normal course of business and barring any failure of systems related thereto or unusual staffing shortages. If at any time it appears to PROFESSIONAL that the proposed scope of services to be performed on the different aspects of any PROJECT will exceed that which was authorized by PVWC, PROFESSIONAL shall clearly indicate same in its continuing written reports. The PROJECT shall be invoiced separately. Each invoice shall include a breakdown of hours expended along with the names of individual expending said hours, along with a breakdown of charges from subcontractors where applicable and out-of-pocket expenses chargeable to the PROJECT. Each invoice shall include a summary sheet including total amount billed for the time period covered by the invoice and the time period covered, total amount billed to date, total not-to-exceed dollar amount for cost of services (said amounts as set forth or defined in Paragraph 3 herein), and balance remaining.

4. PROFESSIONAL shall be responsible to PVWC for any subcontractors and outside associates or professional it engages to assist it in the performance of the services required under this AGREEMENT.

5. PVWC will provide to PROFESSIONAL all available information, including previous reports and any other data in its possession relevant to the subject PROJECT. Further, PVWC will be responsible for providing PROFESSIONAL access to all public and private property in connection with services to be performed for the PROJECT.

6. Both PVWC and PROFESSIONAL understand that the goal of this AGREEMENT is to complete all phases of the subject PROJECT in a reasonably expeditious fashion. To this end each pledges to the other full cooperation.

7. The services to be performed under this AGREEMENT for the PROJECT shall be deemed to be completed when the scope of work authorized by PVWC for the PROJECT has satisfactorily been fulfilled.

8. By notice in writing at any time, PVWC may change the general scope of services required by PROFESSIONAL as set forth herein. In such event an equitable adjustment, if appropriate, in compensation shall be agreed to in writing prior to PROFESSIONAL'S performing the changed services.

9. PROFESSIONAL shall hold secret and confidential all information designated by PVWC as confidential. PROFESSIONAL shall not reveal any designated confidential information to a third party unless the disclosing party was lawfully possessed with the information before receipt of same from the party claiming confidentiality and whose information has been designated as described herein as being confidential, or applicable law, regulation, court order or any agency of competent jurisdiction requires its disclosure; or the failure to disclose the information would pose an imminent and substantial threat to human health or the environment.

10. PROFESSIONAL shall maintain insurance.

Insurance Coverages

- A. Commercial General Liability: \$1,000,000 Each Occurrence / \$2,000,000 Aggregate (Completed Operations must be included)
- B. Business Automobile Liability: \$1,000,000 combined single limit any one accident (All owned, hired or non-owned automobiles used in connection with this agreement)
- C. Professional Liability/Errors & Omissions Liability: \$1,000,000 each claim / \$2,000,000 annual aggregate (Must not contain cyber, privacy or network-related exclusions)
- D. Workers' Compensation: Statutory
- E. Employers' Liability: \$1,000,000
- F. Crime: \$1,000,000 (Must include Employee Theft and Client Coverage)

PROFESSIONAL shall provide to the PVWC certificates of insurance as to each of the above which evidence that the policies are in effect.

11. This AGREEMENT shall be interpreted in accordance with the laws of the State of New Jersey and any litigation/arbitration relating to the AGREEMENT shall be venued in New Jersey. In the event of litigation, the parties agree and consent to the action being initiated in the Superior Court of New Jersey, Passaic County.

12. PROFESSIONAL represents that it is an independent professional and not an employee of PVWC.

13. If a dispute or complaint arises concerning this AGREEMENT, PVWC and PROFESSIONAL will negotiate a resolution of the dispute. Should negotiations be unsuccessful, the resolution of the dispute shall be submitted to arbitration in accordance with the current Construction Industry Arbitration Rules of the American Arbitration Association and the arbitration proceeding shall be venued in New Jersey. Any decision rendered by the arbitrators shall be final. Judgment may be entered upon the decision in any court having jurisdiction. The decision shall not be subject to modification or appeal except to the extent permitted by Sections 10 and 11 of the Federal Arbitration Act (9 U.S.C. 10, 11). Notwithstanding the aforementioned, disputes which have a total value (exclusive of interest) in excess of the dollar amount for cost of services (said dollar amount as stipulated in paragraph 3 herein) shall not be arbitrated but shall be litigated.

14. All notices required or intended under this AGREEMENT may be delivered in person, by facsimile or express mail. All notices shall be effective upon the date of receipt by the parties. Notices shall be delivered or sent to the other party at the address appearing in this AGREEMENT. An address may only be changed by written notice to the other party.

15. During the performance of this contract, the contractor agrees as follows:

a) The contractor or subcontractor, where applicable, will not discriminate against any employee or applicant for employment because of age, race, creed, color, national origin, ancestry, marital status, affectional or sexual orientation and gender identity or expression, disability, nationality or sex. Except with respect to affectional or sexual orientation and gender identity or expression, the contractor will ensure that equal employment opportunity is afforded to such applicants in recruitment and employment, and that employees are treated during employment, without regard to their age, race, creed, color, national origin, ancestry, marital status, affectional or sexual orientation, gender identity or expression, disability, nationality or sex. Such equal employment opportunity shall include but not be limited to the following: employment, upgrading, demotion or transfer; recruitment or recruitment advertising; layoff or termination; rates of pay or other forms of compensation; and selection for training, including apprenticeship. The contractor agrees to post in conspicuous places, available to employees and applicants for employment, notices to be provided by the Public Agency Compliance Officer setting forth the provisions of this nondiscrimination clause.

b) The contractor or subcontractor, where applicable, will, in all solicitations or advertisements for employees placed by or on behalf of the contractor, state that all qualified applicants will receive consideration for employment without regard to age, race, creed, color, national origin, ancestry, marital status, affectional or sexual orientation, gender identity or expression, disability, nationality or sex.

c) The contractor or subcontractor, where applicable, will send to each labor union or representative or workers with which it has a collective bargaining agreement or other contract or understanding, a notice, to be provided by the agency contracting officer advising the labor union or workers' representative of the contractor's commitments under this act and shall post copies of the notice in conspicuous places available to employees and applicants for employment.

d) The contractor or subcontractor, where applicable, agrees to comply with any regulations promulgated by the Treasurer pursuant to N.J.S.A. 10:5-31 et seq. as amended and supplemented from time to time and the Americans with Disabilities Act.

e) The contractor or subcontractor agrees to make good faith efforts to afford equal employment opportunities to minority and women workers consistent with Good faith efforts to meet targeted county employment goals established in accordance with N.J.A.C. 17:27-5.2, or Good faith efforts to meet targeted county employment goals determined by the Division, pursuant to N.J.A.C. 17:27-5.2.

f) The contractor or subcontractor agrees to inform in writing its appropriate recruitment agencies including, but not limited to, employment agencies, placement bureaus, colleges, universities, labor unions, that it does not discriminate on the basis of age, creed, color, national origin, ancestry, marital status, affectional or sexual orientation, gender identity or expression, disability, nationality or sex, and that it will discontinue the use of any recruitment agency which engages in direct or indirect discriminatory practices.

g) The contractor or subcontractor agrees to revise any of its testing procedures, if necessary, to assure that all personal testing conforms with the principles of job-related testing, as

established by the statutes and court decisions of the State of New Jersey and as established by applicable Federal law and applicable Federal court decisions.

h) In conforming with the applicable employment goals, the contractor or subcontractor agrees to review all procedures relating to transfer, upgrading, downgrading and layoff to ensure that all such actions are taken without regard to age, creed, color, national origin, ancestry, marital status, affectional or sexual orientation, gender identity or expression, disability, nationality or sex, consistent with the statutes and court decisions of the State of New Jersey, and applicable Federal law and applicable Federal court decisions.

i) The contractor shall submit to the public agency, after notification of award but prior to execution of a goods and services contract, one of the following three documents:

- Letter of Federal Affirmative Action Plan Approval
- Certificate of Employee Information Report
- Employee Information Report Form AA302

j) The contractor and its subcontractor shall furnish such reports or other documents to the Division of Public Contracts Equal Employment Opportunity Compliance as may be requested by the Division from time to time in order to carry out the purposes of these regulations, and public agencies shall furnish such information as may be requested by the Division of Public Contracts Equal Employment Opportunity Compliance for conducting a compliance investigation pursuant to Subchapter 10 of the Administrative Code at N.J.A.C. 17:27.

16. This AGREEMENT is subject to termination at the conclusion of all of the Contract work, time being of the essence as described herein, unless extended by the mutual agreement of the Parties. PVWC retains the right to terminate the PROFESSIONAL upon 15 days' notice to the PROFESSIONAL, which notice shall be effective when given to the PROFESSIONAL in writing at the PROFESSIONAL'S place of business by way of certified mail return receipt requested and regular mail. No other Notice shall be necessary. Should termination under this Article take place, the PROFESSIONAL shall be entitled to compensation for all authorized Contract work completed satisfactorily to the date of termination. PVWC shall be the sole judge of satisfactory work.

17. This AGREEMENT, including any schedules, attachments and referenced documents, is the entire agreement between PVWC and PROFESSIONAL. Any prior or contemporaneous agreements, promises, negotiations or representations not expressly stated herein are of no force and effect. Any changes to this AGREEMENT shall be in writing and signed by the PVWC and PROFESSIONAL.

18. A waiver or breach of any term, condition or covenant by a party shall not constitute a waiver or breach of any other term, condition or covenant. If any court of competent jurisdiction declares a provision of the AGREEMENT invalid, illegal or otherwise unenforceable, the remaining provisions of the AGREEMENT shall remain in full force and effect.

19. The effective date of this AGREEMENT shall be as of the date set forth hereinabove, or where such date is not indicated, the effective date of the AGREEMENT shall be when the last of the two parties is in full possession of a fully executed AGREEMENT document.

20. PROFESSIONAL'S hourly rates for technical and related support services and non-labor expenses shall be as set forth in the QUALIFICATIONS.

21. PROFESSIONAL understands and agrees that upon submission to PVWC and upon receipt of proper payment as provided for in this AGREEMENT, any reports, data, logs or other information provided to PVWC pursuant to the terms and conditions of this AGREEMENT (and which

are not designated in accordance with Paragraph 9 of this AGREEMENT as being confidential) are deemed to be non-proprietary to the extent that PVWC, in its sole discretion, may utilize the information submitted for whatever purposes it deems necessary or desirable without seeking permission from PROFESSIONAL, and without providing any additional compensation to PROFESSIONAL; provided, however, that PVWC shall have sole responsibility for use of such work products in applications for which they may not originally have been intended. Reports, data, logs and other information provided to PVWC by PROFESSIONAL shall become the property of PVWC provided, however, that PROFESSIONAL shall have unrestricted right to their use.

22. PVWC designates the Executive Director, the Director of Engineering, or the General Counsel of the PVWC as its designated representative having authority to give instructions, receive information, define PVWC'S policies, and make decisions with respect to the scope of the work to be performed. PVWC reserves the right to change these designees from time to time and will notify PROFESSIONAL of any change(s) in writing.

23. Except as otherwise approved by PVWC, for the PROJECT, PVWC will be responsible for furnishing all approvals and permits from governmental authorities and other entities having jurisdiction over the scope of the work to be performed and approvals from others as may be necessary for the timely completion of the said work, including payment of all permit fees.

24. This AGREEMENT may be executed in several counterparts and all so executed documents shall constitute one agreement, binding on all the parties hereto, notwithstanding that all the parties are not signatory to the original or the same counterpart.

IN WITNESS WHEREOF, the parties hereto have made and executed this AGREEMENT by their duly authorized officers, and have affixed their corporate seals, as of the day and year shown on the cover page.

NW FINANCIAL GROUP, LLC

Witness or Attest

Secretary

(Seal)

By: _____
Authorized Signatory

PASSAIC VALLEY WATER COMMISSION

By: _____
LOUIS AMODIO
Administrative Secretary

By: _____
JEFFREY LEVINE
President

EXHIBIT B

RESOLUTION NO. 24-117

PASSAIC VALLEY WATER COMMISSION

**RESOLUTION TO AWARD CONTRACT NO. 24-PD-02 ENTITLED
"PROFESSIONAL SERVICES FOR W-4 LICENSED OPERATOR"**

DATE OF ADOPTION: OCTOBER 23, 2024

Introduced by Commissioner: **RIGO SANCHEZ**

Seconded by Commissioner: **JOSEPH KOLODZIEJ**

WHEREAS, Passaic Valley Water Commission ("PVWC") has solicited for Extraordinary Unspecifiable Services ("EUS's") for Contract No. 24-PD-02 entitled "Professional Services for W-4 Licensed Operator" (hereinafter the "Project"); and

WHEREAS, said Contract shall be awarded as an EUS under the Non-Fair and Open Process and N.J.S.A. 40A:11-5(1)(a)(i) for performing distribution management services; and

WHEREAS, PVWC is required under the State of New Jersey's Amended Administrative Consent Order to hire a professional firm to assist PVWC with performing public outreach for the reservoir projects; and

WHEREAS, the firm of J & J Utility Consulting Services, LLC of Verona, New Jersey (the "Awardee") was determined to be professionally qualified and capable of performing the required services with respect to the Project, with reimbursement to be on a Take-and-Pay, Time-and-Materials basis, not to exceed \$225,000.00 over a period of one (1) year, as stipulated by the Commission in the Form of Agreement for Professional Services (the "Contract"); and

WHEREAS, a copy of the Contract is attached hereto as **Exhibit A**; and

WHEREAS, it is in the best interest of PVWC, its users and constituent municipalities to engage, or continue to engage, the services of the Awardee at this time; and

WHEREAS, PVWC's Chief Financial Officer has certified, with respect hereto, that funds are currently available for said purpose and a copy of the said certification is attached hereto and made a part hereof as **Exhibit B**.

NOW, THEREFORE, BE IT RESOLVED, by Passaic Valley Water Commission, in the County of Passaic, New Jersey:

1. That PVWC hereby awards the Contract to the Awardee in accordance with N.J.S.A. 40A:11-5(1)(a)(i) and N.J.S.A. 19:44A-1 et seq. as set forth hereinabove; and
2. That an appropriate official of PVWC, on behalf of PVWC, is hereby authorized and directed to execute the Contract hereby awarded to the Awardee and the Secretary of PVWC to attest to the Contract and such other officers, employees and officials of PVWC are hereby authorized to perform such acts and execute such documents as are necessary to implement the terms and intentions of this Resolution; and
3. That this matter shall be advertised as required by New Jersey law, in accordance with an appropriate form of notice, and a copy of this Resolution and Agreement shall be placed on file and made available for inspection at the office of the Administrative Secretary of Passaic Valley Water Commission.

RECORD OF COMMISSION VOTE ON FINAL PASSAGE

| | AYE | NAY | ABSTAIN | ABSENT |
|--------------------------|-----------------|------------|----------------|-----------------|
| SANCHEZ, R. | <u>X</u> | — | — | — |
| COTTON, R. | <u>X</u> | — | — | — |
| DEPADUA, C. | <u>X</u> | — | — | — |
| KOLODZIEJ, J. | <u>X</u> | — | — | — |
| LEVINE, J. | <u>X</u> | — | — | — |
| VAN RENSALIER, R. | — | — | — | <u>X</u> |
| FRIEND, G. | <u>X</u> | — | — | — |

Adopted at a meeting of Passaic Valley Water Commission.



President
JEFFREY LEVINE

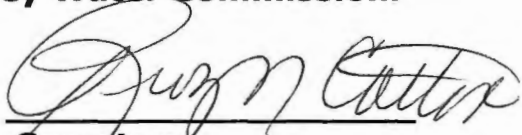

Secretary
RUBY N. COTTON

This Resolution, when adopted, must remain in the custody of the Administrative Secretary.

CERTIFICATION

I, LOUIS AMODIO, Administrative Secretary of the Passaic Valley Water Commission in the County of Passaic, and the State of New Jersey do hereby certify that the foregoing Resolution is a true copy thereof of the foregoing Resolution duly passed and adopted by a majority of a legal quorum of the full membership of the Passaic Valley Water Commission at its duly noticed and convened meeting of the said Commission on October 23, 2024.



LOUIS AMODIO
Administrative Secretary

EXHIBIT A

PASSAIC VALLEY WATER COMMISSION

REQUEST FOR PROPOSALS FOR PROFESSIONAL SERVICES (OR EXTRAORDINARY UNSPECIFIABLE SERVICES)

APPENDIX C

FORM OF AGREEMENT

THIS AGREEMENT (hereinafter "AGREEMENT") made as of _____, 20__ between PASSAIC VALLEY WATER COMMISSION ("PVWC"), a Public Utility Company organized pursuant to its enabling statute (N.J.S.A. 40:62-108 *et seq.*), having its principal place of business at 1525 Main Avenue, Clifton, New Jersey 07011, and J & J Utility Consulting, LLC, a professional firm (hereinafter "PROFESSIONAL") having a place of business at 88 Woodland Avenue, Verona, New Jersey.

WHEREAS, PVWC desires professional services as applicable, to assist PVWC in its efforts related to **Project Number 24-PD-02** entitled **Professional Services for W-4 Licensed Operator** (hereinafter the "PROJECT"); and

WHEREAS, PVWC requires Professional Services to assist it in implementing the PROJECT; and:

WHEREAS, PROFESSIONAL represents that it has the experience and the required professional knowledge to provide the professional services, and/or extraordinary unspecifiable services, as applicable (hereinafter "PROFESSIONAL SERVICES"), and as required by PVWC in this regard as set forth in the "Public Notice", "Table of Contents", and the "Request for Proposals" of the "Request for Proposals for Professional Services (or Extraordinary Unspecifiable Services)", and Appendices A, B, C, & D of the Solicitation (and including, where applicable, Appendix E with additional technical and other requirements attached thereto); all of which, along with a copy of the PROFESSIONAL'S proposal dated September , 2024, are collectively referred to herein as the "PROPOSAL"; and

WHEREAS, the AGREEMENT shall be for **a one-year period of time** commencing on the Effective Date of this AGREEMENT as defined in Paragraph 19 herein, and for any extended periods authorized by PVWC.

WHEREAS, PVWC and PROFESSIONAL are desirous of entering into a consulting agreement to cover the PROFESSIONAL SERVICES authorized by PVWC and required for the PROJECT; and

NOW, THEREFORE, in consideration of the mutual promises herein, PVWC and PROFESSIONAL agree that the terms and conditions of this AGREEMENT are the following:

1. PROFESSIONAL shall provide the PROFESSIONAL SERVICES authorized by PVWC and required for the PROJECT. PROFESSIONAL'S obligations under this AGREEMENT are solely for the benefit of PVWC and no other party is intended to benefit or have rights hereunder.

2. PROFESSIONAL shall perform the PROFESSIONAL SERVICES as defined under this AGREEMENT at a level customary for competent and prudent professional service providers, all as applicable, performing such services at the time and place where the services are provided ("STANDARD OF CARE"). These services will be provided by professional service providers in the appropriate disciplines, and by other professionals and individuals skilled in other technical disciplines, as appropriate. PROFESSIONAL shall be responsible for the professional quality, technical accuracy, timely completion and the coordination of all aspects of its services including reports and

other deliverables and services provided under this AGREEMENT. The services to be performed by PROFESSIONAL shall conform to the generally accepted codes and regulations applicable to the subject PROJECT. PROFESSIONAL agrees to indemnify and hold PVWC harmless from all losses and damages resulting from PROFESSIONAL'S failure to meet the STANDARD OF CARE. Further, PROFESSIONAL shall correct and re-perform any services not conforming to the required STANDARD OF CARE without additional compensation and cost to PVWC, (including, but not limited to pending written or oral testimony, reports, etc., which might occur from activities resulting from the performance of this AGREEMENT which were caused by PROFESSIONAL'S performance). In addition, PROFESSIONAL shall indemnify and hold harmless PVWC and its officers, agents and employees of PVWC from and against any losses, claims, damages, or liabilities to which PVWC may become subject insofar as and to the extent they arise out of the deviation from the STANDARD OF CARE in the performance of the services by the PROFESSIONAL, hereunder.

3. The cost of services for those portions, if any, of the PROJECT that are pre-authorized in writing by the Commission (and subsequently performed by PROFESSIONAL pursuant to this AGREEMENT for PROJECT) shall be as stipulated in **Appendix D** or in accordance with the QUALIFICATIONS **not to exceed \$225,000.00**.

PROFESSIONAL shall invoice PVWC its services hereunder after completion thereof and on the basis of reports and accompanying documents, if appropriate, on a monthly basis, including therein information as to progress in performance as against one hundred percent (100%) completion thereof and also showing amounts previously compensated hereunder, as against the total authorization. To the extent items appearing on invoices presented by PROFESSIONAL are not contested, PVWC will remit payment of the invoice as soon as it can reasonably process same in the normal course of business and barring any failure of systems related thereto or unusual staffing shortages. If at any time it appears to PROFESSIONAL that the proposed scope of services to be performed on the different aspects of any PROJECT will exceed that which was authorized by PVWC, PROFESSIONAL shall clearly indicate same in its continuing written reports. The PROJECT shall be invoiced separately. Each invoice shall include a breakdown of hours expended along with the names of individual expending said hours, along with a breakdown of charges from subcontractors where applicable and out-of-pocket expenses chargeable to the PROJECT. Each invoice shall include a summary sheet including total amount billed for the time period covered by the invoice and the time period covered, total amount billed to date, total not-to-exceed dollar amount for cost of services (said amounts as set forth or defined in Paragraph 3 herein), and balance remaining.

4. PROFESSIONAL shall be responsible to PVWC for any subcontractors and outside associates or professional it engages to assist it in the performance of the services required under this AGREEMENT.

5. PVWC will provide to PROFESSIONAL all available information, including previous reports and any other data in its possession relevant to the subject PROJECT. Further, PVWC will be responsible for providing PROFESSIONAL access to all public and private property in connection with services to be performed for the PROJECT.

6. Both PVWC and PROFESSIONAL understand that the goal of this AGREEMENT is to complete all phases of the subject PROJECT in a reasonably expeditious fashion. To this end each pledges to the other full cooperation.

7. The services to be performed under this AGREEMENT for the PROJECT shall be deemed to be completed when the scope of work authorized by PVWC for the PROJECT has satisfactorily been fulfilled.

8. By notice in writing at any time, PVWC may change the general scope of services required by PROFESSIONAL as set forth herein. In such event an equitable adjustment, if appropriate, in compensation shall be agreed to in writing prior to PROFESSIONAL'S performing the changed services.

9. PROFESSIONAL shall hold secret and confidential all information designated by PVWC as confidential. PROFESSIONAL shall not reveal any designated confidential information to a third party unless the disclosing party was lawfully possessed with the information before receipt of same from the party claiming confidentiality and whose information has been designated as described herein as being confidential, or applicable law, regulation, court order or any agency of competent jurisdiction requires its disclosure; or the failure to disclose the information would pose an imminent and substantial threat to human health or the environment.

10. PROFESSIONAL shall maintain insurance.

Insurance Coverages

- A. Commercial General Liability: \$1,000,000 Each Occurrence / \$1,000,000 Aggregate (Completed Operations must be included)
- B. Business Automobile Liability: \$1,000,000 combined single limit any one accident (All owned, hired or non-owned automobiles used in connection with this agreement)
- C. Professional Liability/Errors & Omissions Liability: \$1,000,000 each claim / \$1,000,000 annual aggregate (Must not contain cyber, privacy or network-related exclusions)
- D. Workers' Compensation: Statutory
- E. Employers' Liability: \$1,000,000

PROFESSIONAL shall provide to the PVWC certificates of insurance as to each of the above which evidence that the policies are in effect.

11. This AGREEMENT shall be interpreted in accordance with the laws of the State of New Jersey and any litigation/arbitration relating to the AGREEMENT shall be venued in New Jersey. In the event of litigation, the parties agree and consent to the action being initiated in the Superior Court of New Jersey, Passaic County.

12. PROFESSIONAL represents that it is an independent professional and not an employee of PVWC.

13. If a dispute or complaint arises concerning this AGREEMENT, PVWC and PROFESSIONAL will negotiate a resolution of the dispute. Should negotiations be unsuccessful, the resolution of the dispute shall be submitted to arbitration in accordance with the current Construction Industry Arbitration Rules of the American Arbitration Association and the arbitration proceeding shall be venued in New Jersey. Any decision rendered by the arbitrators shall be final. Judgment may be entered upon the decision in any court having jurisdiction. The decision shall not be subject to modification or appeal except to the extent permitted by Sections 10 and 11 of the Federal Arbitration Act (9 U.S.C. 10, 11). Notwithstanding the aforementioned, disputes which have a total value (exclusive of interest) in excess of the dollar amount for cost of services (said dollar amount as stipulated in paragraph 3 herein) shall not be arbitrated but shall be litigated.

14. All notices required or intended under this AGREEMENT may be delivered in person, by facsimile or express mail. All notices shall be effective upon the date of receipt by the parties.

Notices shall be delivered or sent to the other party at the address appearing in this AGREEMENT. An address may only be changed by written notice to the other party.

15. During the performance of this contract, the contractor agrees as follows:

a) The contractor or subcontractor, where applicable, will not discriminate against any employee or applicant for employment because of age, race, creed, color, national origin, ancestry, marital status, affectional or sexual orientation and gender identity or expression, disability, nationality or sex. Except with respect to affectional or sexual orientation and gender identity or expression, the contractor will ensure that equal employment opportunity is afforded to such applicants in recruitment and employment, and that employees are treated during employment, without regard to their age, race, creed, color, national origin, ancestry, marital status, affectional or sexual orientation, gender identity or expression, disability, nationality or sex. Such equal employment opportunity shall include but not be limited to the following: employment, upgrading, demotion or transfer; recruitment or recruitment advertising; layoff or termination; rates of pay or other forms of compensation; and selection for training, including apprenticeship. The contractor agrees to post in conspicuous places, available to employees and applicants for employment, notices to be provided by the Public Agency Compliance Officer setting forth the provisions of this nondiscrimination clause.

b) The contractor or subcontractor, where applicable, will, in all solicitations or advertisements for employees placed by or on behalf of the contractor, state that all qualified applicants will receive consideration for employment without regard to age, race, creed, color, national origin, ancestry, marital status, affectional or sexual orientation, gender identity or expression, disability, nationality or sex.

c) The contractor or subcontractor, where applicable, will send to each labor union or representative or workers with which it has a collective bargaining agreement or other contract or understanding, a notice, to be provided by the agency contracting officer advising the labor union or workers' representative of the contractor's commitments under this act and shall post copies of the notice in conspicuous places available to employees and applicants for employment.

d) The contractor or subcontractor, where applicable, agrees to comply with any regulations promulgated by the Treasurer pursuant to N.J.S.A. 10:5-31 et seq. as amended and supplemented from time to time and the Americans with Disabilities Act.

e) The contractor or subcontractor agrees to make good faith efforts to afford equal employment opportunities to minority and women workers consistent with Good faith efforts to meet targeted county employment goals established in accordance with N.J.A.C. 17:27-5.2, or Good faith efforts to meet targeted county employment goals determined by the Division, pursuant to N.J.A.C. 17:27-5.2.

f) The contractor or subcontractor agrees to inform in writing its appropriate recruitment agencies including, but not limited to, employment agencies, placement bureaus, colleges, universities, labor unions, that it does not discriminate on the basis of age, creed, color, national origin, ancestry, marital status, affectional or sexual orientation, gender identity or expression, disability, nationality or sex, and that it will discontinue the use of any recruitment agency which engages in direct or indirect discriminatory practices.

g) The contractor or subcontractor agrees to revise any of its testing procedures, if necessary, to assure that all personal testing conforms with the principles of job-related testing, as established by the statutes and court decisions of the State of New Jersey and as established by applicable Federal law and applicable Federal court decisions.

h) In conforming with the applicable employment goals, the contractor or subcontractor agrees to review all procedures relating to transfer, upgrading, downgrading and layoff to ensure that all such actions are taken without regard to age, creed, color, national origin, ancestry, marital status, affectional or sexual orientation, gender identity or expression, disability, nationality or sex, consistent with the statutes and court decisions of the State of New Jersey, and applicable Federal law and applicable Federal court decisions.

i) The contractor shall submit to the public agency, after notification of award but prior to execution of a goods and services contract, one of the following three documents:

- Letter of Federal Affirmative Action Plan Approval
- Certificate of Employee Information Report
- Employee Information Report Form AA302

j) The contractor and its subcontractor shall furnish such reports or other documents to the Division of Public Contracts Equal Employment Opportunity Compliance as may be requested by the Division from time to time in order to carry out the purposes of these regulations, and public agencies shall furnish such information as may be requested by the Division of Public Contracts Equal Employment Opportunity Compliance for conducting a compliance investigation pursuant to Subchapter 10 of the Administrative Code at N.J.A.C. 17:27.

16. This AGREEMENT is subject to termination at the conclusion of all of the Contract work, time being of the essence as described herein, unless extended by the mutual agreement of the Parties. PVWC retains the right to terminate the PROFESSIONAL upon 15 days' notice to the PROFESSIONAL, which notice shall be effective when given to the PROFESSIONAL in writing at the PROFESSIONAL'S place of business by way of certified mail return receipt requested and regular mail. No other Notice shall be necessary. Should termination under this Article take place, the PROFESSIONAL shall be entitled to compensation for all authorized Contract work completed satisfactorily to the date of termination. PVWC shall be the sole judge of satisfactory work.

17. This AGREEMENT, including any schedules, attachments and referenced documents, is the entire agreement between PVWC and PROFESSIONAL. Any prior or contemporaneous agreements, promises, negotiations or representations not expressly stated herein are of no force and effect. Any changes to this AGREEMENT shall be in writing and signed by the PVWC and PROFESSIONAL.

18. A waiver or breach of any term, condition or covenant by a party shall not constitute a waiver or breach of any other term, condition or covenant. If any court of competent jurisdiction declares a provision of the AGREEMENT invalid, illegal or otherwise unenforceable, the remaining provisions of the AGREEMENT shall remain in full force and effect.

19. The effective date of this AGREEMENT shall be as of the date set forth hereinabove, or where such date is not indicated, the effective date of the AGREEMENT shall be when the last of the two parties is in full possession of a fully executed AGREEMENT document.

20. PROFESSIONAL'S hourly rates for technical and related support services and non-labor expenses shall be as set forth in the QUALIFICATIONS.

21. PROFESSIONAL understands and agrees that upon submission to PVWC and upon receipt of proper payment as provided for in this AGREEMENT, any reports, data, logs or other information provided to PVWC pursuant to the terms and conditions of this AGREEMENT (and which are not designated in accordance with Paragraph 9 of this AGREEMENT as being confidential) are deemed to be non-proprietary to the extent that PVWC, in its sole discretion, may utilize the

information submitted for whatever purposes it deems necessary or desirable without seeking permission from PROFESSIONAL, and without providing any additional compensation to PROFESSIONAL; provided, however, that PVWC shall have sole responsibility for use of such work products in applications for which they may not originally have been intended. Reports, data, logs and other information provided to PVWC by PROFESSIONAL shall become the property of PVWC provided, however, that PROFESSIONAL shall have unrestricted right to their use.

22. PVWC designates the Executive Director, the Director of Engineering, or the General Counsel of the PVWC as its designated representative having authority to give instructions, receive information, define PVWC'S policies, and make decisions with respect to the scope of the work to be performed. PVWC reserves the right to change these designees from time to time and will notify PROFESSIONAL of any change(s) in writing.

23. Except as otherwise approved by PVWC, for the PROJECT, PVWC will be responsible for furnishing all approvals and permits from governmental authorities and other entities having jurisdiction over the scope of the work to be performed and approvals from others as may be necessary for the timely completion of the said work, including payment of all permit fees.

24. This AGREEMENT may be executed in several counterparts and all so executed documents shall constitute one agreement, binding on all the parties hereto, notwithstanding that all the parties are not signatory to the original or the same counterpart.

IN WITNESS WHEREOF, the parties hereto have made and executed this AGREEMENT by their duly authorized officers, and have affixed their corporate seals, as of the day and year shown on the cover page.

J & J UTILITY CONSULTING, LLC

Witness or Attest

Secretary

(Seal)

By: _____
Authorized Signatory

PASSAIC VALLEY WATER COMMISSION

By: _____
LOUIS AMODIO
Administrative Secretary

By: _____
JEFFREY LEVINE
President

EXHIBIT B

RESOLUTION NO. 24-118

PASSAIC VALLEY WATER COMMISSION

**RESOLUTION TO AUTHORIZE THE SALE OF ITS SURPLUS PERSONAL
PROPERTY NO LONGER NEEDED FOR PUBLIC USE ON AN ON-LINE
AUCTION WEBSITE**

DATE OF ADOPTION: OCTOBER 23, 2024

Introduced by Commissioner: **RIGO SANCHEZ**

Seconded by Commissioner: **JOSEPH KOLODZIEJ**

WHEREAS, Passaic Valley Water Commission ("PVWC") is the owner of certain miscellaneous materials, vehicles, and equipment ("Surplus Personal Property") which PVWC has determined are no longer needed for public use; and

WHEREAS, the Local Unit Technology Pilot Program and Study Act (P.L. 2001, c. 30) authorizes the sale of Surplus Personal Property no longer needed for public use through the use of an on-line auction service; and

WHEREAS, in accordance with N.J.S.A. 40A:11-36, a Public Notice (legal newspaper advertisement) informing the public as to the nature of the Surplus Personal Property being sold and how to obtain more information on the sale, will be published (and placed on PVWC's website), within the required time frames, and a copy of the Public Notice (with a general description of the Surplus Personal Property to be included in the auction) is attached hereto and made a part hereof as **Exhibit A**; and

WHEREAS, pursuant to the Passaic County Cooperative Contract, PVWC will utilize the on-line services of GovDeals, Inc., 100 Capitol Commerce Blvd., Montgomery, AL 36117, Phone: (866) 377-1494; Fax: (334) 387-0519 located at www.GovDeals.com for conducting the sales; and

WHEREAS, the terms and conditions of the agreement entered into between GovDeals and PVWC, along with the agreed-to compensation to GovDeals, are available at www.GovDeals.com and a copy of the said agreement is on file and available for inspection at the office of the Administrative Secretary of PVWC; and

WHEREAS, the scheduled date and time for the auction, with items and/or groups of items as applicable, shall be as set forth in the Public Notice; and

WHEREAS, pursuant to N.J.S.A. 40A:11-36, sales shall be held not less than seven (7) days, nor more than fourteen (14) days after the latest publication of the Public Notice; and

WHEREAS, all sales will be made to the highest bidder, all sales shall be final, and all Surplus Personal Property will be sold "As Is-Where Is", free from any guarantee or warranty; and

WHEREAS, all Surplus Personal Property purchased will be required to be removed by the successful bidder(s) from PVWC's premises within ten (10) business days of the close of the auction, and any and all Surplus Personal Property not sold at the auction (or removed by the successful bidders within the stipulated time frame) shall subsequently be properly disposed of by PVWC personnel; and

WHEREAS, within the parameters established by the governing law, PVWC reserves the right to accept or reject any or all bids.

NOW, THEREFORE, BE IT RESOLVED, by Passaic Valley Water Commission, in the County of Passaic, New Jersey:

1. PVWC is hereby authorized to sell the Surplus Personal Property as generally described and set forth in the Public Notice attached hereto as **Exhibit A**, utilizing the on-line auction website entitled www.GovDeals.com; and
2. Said Public Notice shall be published in a newspaper circulating in the member municipalities of PVWC no earlier than seven (7) days nor no later than fourteen (14) days prior to said sale; and
3. That the appropriate officials and employees of the Commission are hereby authorized to perform such acts and execute such documents as are necessary to implement the terms and intentions of this Resolution and the submissions provided in connection therewith.

RECORD OF COMMISSION VOTE ON FINAL PASSAGE

| | AYE | NAY | ABSTAIN | ABSENT |
|--------------------------|-----------------|------------|----------------|-----------------|
| VAN RENSALIER, R. | — | — | — | <u>X</u> |
| COTTON, R. | <u>X</u> | — | — | — |
| SANCHEZ, R. | <u>X</u> | — | — | — |
| KOLODZIEJ, J. | <u>X</u> | — | — | — |
| DEPADUA, C. | <u>X</u> | — | — | — |
| FRIEND, G. | <u>X</u> | — | — | — |
| LEVINE, J. | <u>X</u> | — | — | — |

Adopted at a meeting of Passaic Valley Water Commission.

President
JEFFREY LEVINE



Secretary
RUBY N. COTTON

This Resolution, when adopted, must remain in the custody of the Administrative Secretary.

CERTIFICATION

I, LOUIS AMODIO, Administrative Secretary of the Passaic Valley Water Commission in the County of Passaic, and the State of New Jersey do hereby certify that the foregoing Resolution is a true copy thereof of the foregoing Resolution duly passed and adopted by a majority of a legal quorum of the full membership of the Passaic Valley Water Commission at its duly noticed and convened meeting of the said Commission on October 23, 2024.



LOUIS AMODIO
Administrative Secretary

EXHIBIT A

SCHEDULE OF SURPLUS PROPERTY

List of Auction Items:

Vehicles:

| | |
|--------------------------------------|-------------------|
| (17) 2004 Dodge Dakota club cab 4x4 | 1D7HG12K24S746548 |
| (50) 1997 International Utility 4700 | 1HTSCAAN3VH480630 |
| (55) 2008 Ford F 550SD Utility | 1FDAX56R38EC82471 |
| (61) 2006 Ford E250 | 1FTNS24W66HA42080 |
| (89) 1987 Ford F700 Boom Truck | 1FDPK74N4HYA02609 |
| (E19)2007 Holmes Trailer | 5LVBV101X7A013167 |
| (42T) 2005 Pequea Trailer | 4JASL18215G111382 |
| (43T) 2005 Pequea Trailer | 4JASL18225G111383 |
| (45T) 2005 Cross Country Trailer | 431FS182251000935 |

RESOLUTION NO. 24-119

PASSAIC VALLEY WATER COMMISSION

**RESOLUTION TO AWARD CONTRACT NO. 24-V-11 ENTITLED
"FURNISH AND DELIVER SODIUM HYPOCHLORITE"**

DATE OF ADOPTION: OCTOBER 23, 2024

Introduced by Commissioner: **RIGO SANCHEZ**

Seconded by Commissioner: **JOSEPH KOLODZIEJ**

WHEREAS, on October 22, 2024, three (3) bids were received by Passaic Valley Water Commission ("PVWC") for Contract No. 24-V-11 entitled "Furnish and Deliver Sodium Hypochlorite"; and

WHEREAS, the lowest responsible, responsive bid submitted for this contract was that of Univar Solutions USA LLC of Morrisville, Pennsylvania (the "Awardee") with respect to said bid, in the amount of \$1,139,925.00 for a period of one (1) year; and

WHEREAS, the bids have been reviewed by the Engineering Department and the Director of Purchasing and a copy of said bid tabulation sheet is attached hereto and made a part hereof as **Exhibit A**; and

WHEREAS, the Local Public Contracts Law provides for award of the Contract upon receipt of bids and qualifications of bidders therefore; and

WHEREAS, PVWC's Chief Financial Officer has certified, with respect hereto, that funds are currently available for said purpose and a copy of the said certification is attached hereto and made a part hereof as **Exhibit B**;

NOW, THEREFORE, BE IT RESOLVED, by Passaic Valley Water Commission, in the County of Passaic, New Jersey:

1. That PVWC hereby awards the Contract to the Awardee in accordance with N.J.S.A. 40A:11-1 et seq. and N.J.S.A. 19:44A-

20.7, and in accordance with said Response, as set forth hereinabove; and

2. That an appropriate official of PVWC, on behalf of PVWC, is hereby authorized and directed to execute the Contract hereby awarded to the Awardee and the Secretary of PVWC to attest to the Contract and such other officers, employees and officials of PVWC are hereby authorized to perform such acts and execute such documents as are necessary to implement the terms and intentions of this Resolution.

RECORD OF COMMISSION VOTE ON FINAL PASSAGE

| | AYE | NAY | ABSTAIN | ABSENT |
|---------------------------|------------|------------|----------------|---------------|
| SANCHEZ, R. | <u>X</u> | ___ | ___ | ___ |
| COTTON, R. | <u>X</u> | ___ | ___ | ___ |
| DEPADUA, C. | <u>X</u> | ___ | ___ | ___ |
| KOLODZIEJ, J. | <u>X</u> | ___ | ___ | ___ |
| LEVINE, J. | <u>X</u> | ___ | ___ | ___ |
| VAN RENSA LIER, R. | ___ | ___ | ___ | <u>X</u> |
| FRIEND, G. | <u>X</u> | ___ | ___ | ___ |

Adopted at a meeting of Passaic Valley Water Commission.



President
JEFFREY LEVINE

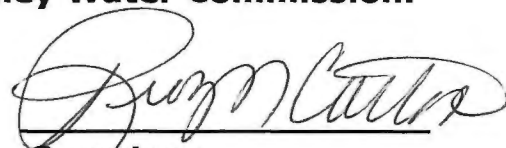

Secretary
RUBY N. COTTON

This Resolution, when adopted, must remain in the custody of the Administrative Secretary.

CERTIFICATION

I, LOUIS AMODIO, Administrative Secretary of the Passaic Valley Water Commission in the County of Passaic, and the State of New Jersey do hereby certify that the foregoing Resolution is a true copy thereof of the foregoing Resolution duly passed and adopted by a majority of a legal quorum of the full membership of the Passaic Valley Water Commission at its duly noticed and convened meeting of the said Commission on October 23, 2024.



LOUIS AMODIO
Administrative Secretary

EXHIBIT A

Title: Furnish and Deliver Sodium Hypochlorite

Contract # 24-V-11

Bid Tabulation Evaluation

Bid Opening Date: October 22, 2024 at 2:00PM

| BIDDERS | BID DEPOSIT | TOTAL AMOUNT OF CONTRACT | REMARKS |
|-----------|---|--------------------------|---|
| Univar | Certified Check | \$1,139,925.00 | <input checked="" type="checkbox"/> Business Registration Cert. |
| | Cashier's Check | | <input type="checkbox"/> PVWC Consent of Surety |
| | <input checked="" type="checkbox"/> Bid Bond | | <input type="checkbox"/> Other Consent of Surety |
| | <input checked="" type="checkbox"/> Not to Exceed \$20,000 | | <input checked="" type="checkbox"/> Public Works Cont. Cert. EEO |
| JCI Jones | Certified Check | \$1,192,500.00 | <input type="checkbox"/> Business Registration Cert. |
| | Cashier's Check | | <input type="checkbox"/> PVWC Consent of Surety |
| | <input checked="" type="checkbox"/> Bid Bond | | <input type="checkbox"/> Other Consent of Surety |
| | <input checked="" type="checkbox"/> X \$20,000 | | <input checked="" type="checkbox"/> Public Works Cont. Cert. EEO |
| Kuehne | Certified Check | \$1,631,250.00 | <input checked="" type="checkbox"/> Business Registration Cert. |
| | Cashier's Check | | <input type="checkbox"/> PVWC Consent of Surety |
| | <input checked="" type="checkbox"/> Bid Bond | | <input type="checkbox"/> Other Consent of Surety |
| | <input checked="" type="checkbox"/> Not to Exceed \$20,000 | | <input checked="" type="checkbox"/> Public Works Cont. Cert. EEO |
| | Certified Check | | <input type="checkbox"/> Business Registration Cert. |
| | Cashier's Check | | <input type="checkbox"/> PVWC Consent of Surety |
| | Bid Bond | | <input type="checkbox"/> Other Consent of Surety |
| | Not to Exceed | | <input type="checkbox"/> Public Works Cont. Cert. EEO |
| | Certified Check | | <input type="checkbox"/> Business Registration Cert. |
| | Cashier's Check | | <input type="checkbox"/> PVWC Consent of Surety |
| | Bid Bond | | <input type="checkbox"/> Other Consent of Surety |
| | Not to Exceed | | <input type="checkbox"/> Public Works Cont. Cert. EEO |
| | Certified Check | | <input type="checkbox"/> Business Registration Cert. |
| | Cashier's Check | | <input type="checkbox"/> PVWC Consent of Surety |
| | Bid Bond | | <input type="checkbox"/> Other Consent of Surety |
| | Not to Exceed | | <input type="checkbox"/> Public Works Cont. Cert. EEO |

EXHIBIT B

OFFICE OF THE COMPTROLLER

CERTIFICATION OF AVAILABILITY OF FUNDS

It is hereby certified that subject to Commission approval of future Budgets, with respect to multi-budget year contracts, there are or will be sufficient available funds for expenditures to be incurred as result of any contract or commitment to be entered into by Passaic Valley Water Commission as follows:

Description of Project or Contract: Contract No.: 24-V-11
"Furnish and Deliver Sodium Hypchlorite"
Univar Solutions USA LLC

Amount of Project or Contract:

\$1,139,925.00- Contract 24-V-11

1. Acct: # 001-1002-421-70-11
PURCHASES/Chemicals
2. Specific Appropriation to which expenditures will be charged:
Budget 2024/2025

Other comments: One Year Commencing in November 2024

Date of Certification: October 22, 2024

Amount Certified: \$1,139,925.00

Yitzchak Weiss
Comptroller and Chief Financial Officer

YW:lb

RESOLUTION # 24-120

RESOLUTION OF PASSAIC VALLEY WATER COMMISSION

RESOLUTION TO AWARD PROJECT 24-PE-05 ENTITLED "PROFESSIONAL ENGINEERING SERVICE FOR DEVELOPMENT OF A FACILITY PLAN FOR STORAGE AND SYSTEM RESILIENCY TO COMPLY WITH LT2 RULE"

DATE OF ADOPTION: OCTOBER 23, 2024

Introduced by Commissioner: **RIGO SANCHEZ**

Seconded by Commissioner: **JOSEPH KOLODZIEJ**

WHEREAS, Passaic Valley Water Commission ("PVWC") has solicited for professional services (or extraordinary un-specifiable Services) for Award Project No. 24-PE-05, entitled "Professional Engineering Service for Development of a Facility Plan for Storage and System Resiliency to Comply with LT2 Rule" (hereinafter the "Project"), with said solicitation and procurement of responses (and evaluation of same) undertaken through a fair and open process, as defined in N.J.S.A. 19:44A-20.7 (hereinafter the "Fair and Open Process"); and

WHEREAS, the Local Public Contracts Law, N.J.S.A. 40A:11-5(1)(a)(i) and the Fair and Open Process require that notice, with respect to contracts for professional services (or extraordinary un-specifiable services), procured through a fair and open process and awarded without competitive bids, must be publicly advertised; and

WHEREAS, following public advertisement as required by New Jersey law, in accordance with an appropriate form of notice, and placement of the said notice on the official website of PVWC, as well as in the official newspaper of PVWC and any other such publications as may have been deemed appropriate, PVWC has received a response to provide professional services (or extraordinary un-specifiable services) related to the Project from three (3) professional (or provider of extraordinary un-specifiable services) providers; and

WHEREAS, responses received for the Project have been evaluated by PVWC based on criteria as set forth in the request for responses for the Project, and a copy of PVWC's Memo including the Evaluation Matrix Summary is attached hereto as **Exhibit A**; and

WHEREAS, based on the said evaluation of the responses received, and as can be seen from the above-referenced PVWC Evaluation Matrix Summary, the firm of **Arcadis U.S., Inc.**, of Fair Lawn, New Jersey (the "Awardee") was determined to be the most professionally qualified and capable of performing the required services

with respect to the Project and the responses received September 19, 2024 (hereinafter the "Responses"), with reimbursement to be on a Take-and-Pay, Time-and-Materials basis, not to exceed \$2,722,029.00 for the Awardee for services related to the Project, as stipulated by the Commission in the Form of Agreement for Professional Services (the "Contract"); and

WHEREAS, a copy of the Contract is attached hereto as **Exhibit B**; and

WHEREAS, it is in the best interest of PVWC, its users and constituent municipalities to engage, or continue to engage, the services of the Awardee at this time; and

WHEREAS, the services to be rendered pursuant hereto constitute professional services (or extraordinary unspecifiable services) within the meaning and intent of the Local Public Contracts Law; and

WHEREAS, the Responses and solicitations are on file in the office of the Administrative Secretary and available for inspection; and

WHEREAS, PVWC's Chief Financial Officer has certified, with respect hereto, that funds are currently available for said purpose and said certificate is attached hereto as **Exhibit C**.

NOW, THEREFORE, BE IT RESOLVED, by Passaic Valley Water Commission, in the County of Passaic, New Jersey;

1. That PVWC hereby awards the Contract to the Awardee in accordance with N.J.S.A. 40A:11-1 et seq. and N.J.S.A. 19:44A-20.7, and in accordance with said Responses, as set forth hereinabove; and
2. That an appropriate official of PVWC, on behalf of PVWC, is hereby authorized and directed to execute the Contract hereby awarded to the Awardee and the Secretary of PVWC to attest to the Contract and such other officers, employees and officials of PVWC are hereby authorized to perform such acts and execute such documents as are necessary to implement the terms and intentions of this Resolution, and
3. That this matter shall be advertised as required by New Jersey law, in accordance with an appropriate form of notice, and a copy of this Resolution and Agreement shall be placed on file and made available for inspection at the office of the Administrative Secretary of Passaic Valley Water Commission.

RECORD OF COMMISSION VOTE ON FINAL PASSAGE

| | AYE | NAY | ABSTAIN | ABSENT |
|--------------------------|------------|------------|----------------|---------------|
| VAN RENSALIER, R. | — | — | — | <u>X</u> |
| COTTON, R. | <u>X</u> | — | — | — |
| SANCHEZ, R. | <u>X</u> | — | — | — |
| KOLODZIEJ, J. | <u>X</u> | — | — | — |
| DEPADUA, C. | <u>X</u> | — | — | — |
| FRIEND, G. | <u>X</u> | — | — | — |
| LEVINE, J. | <u>X</u> | — | — | — |

Adopted at a meeting of Passaic Valley Water Commission.

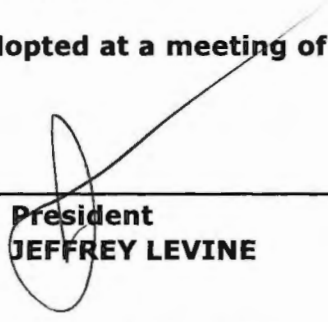

President
JEFFREY LEVINE

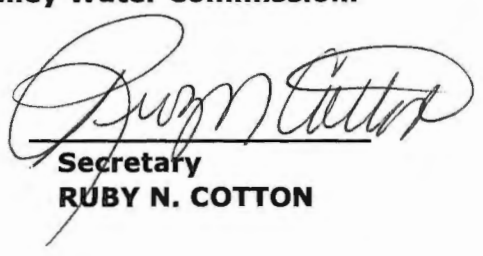

Secretary
RUBY N. COTTON

This Resolution, when adopted, must remain in the custody of the Administrative Secretary.

CERTIFICATION

I, LOUIS AMODIO, Administrative Secretary of the Passaic Valley Water Commission in the County of Passaic, and the State of New Jersey do hereby certify that the foregoing Resolution is a true copy thereof of the foregoing Resolution duly passed and adopted by a majority of a legal quorum of the full membership of the Passaic Valley Water Commission at its duly noticed and convened meeting of the said Commission on October 23, 2024.

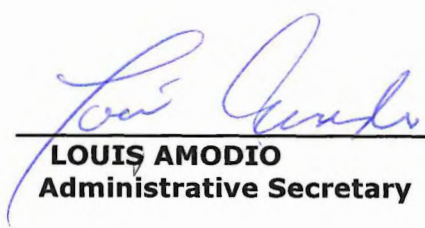

LOUIS AMODIO
Administrative Secretary

EXHIBIT A

**PASSAIC VALLEY WATER COMMISSION
INTEROFFICE MEMORANDUM**

DATE: October 10, 2024
 TO: J. Mueller
 FROM: L. Bresemann
 RE: Project No. 24-PE-05
 Entitled "Professional Engineering Service for Development of a Facility Plan for Storage and System Resiliency to Comply with LT2 Rule"

After receiving permission from the Board to solicit proposals, we received three (3) submissions for the above-referenced project. Five people were assigned to the evaluating committee. Based on the review of the proposals, all three firms were called in to give presentations to the evaluating committee. Based on the proposals and the presentations, the evaluation committee arrived at the weighted scores listed below. Based on the evaluations, it is recommended that Arcadis be awarded this project at a cost not-to-exceed \$2,722,029.00.

| Reviewer | Arcadis US, Inc. | Hazen & Sawyer | H2M Architects & Engineers |
|--------------------|------------------|----------------|----------------------------|
| 1 | 740 | 783.99 | 511.57 |
| 2 | 770 | 763.99 | 751.57 |
| 3 | 880 | 843.99 | 821.57 |
| 4 | 830 | 813.99 | 791.57 |
| 5 | 770 | 783.99 | 701.57 |
| Cost | \$2,722,029.00 | \$3,240,759.00 | \$8,622,000.00 |
| Total Score | 3990.00 | 3989.95 | 3577.85 |

EXHIBIT B

FORM OF PVWC'S STANDARD FORM OF AGREEMENT FOR PROFESSIONAL SERVICES

THIS AGREEMENT (hereinafter "AGREEMENT") made as of _____, 20__ between PASSAIC VALLEY WATER COMMISSION ("PVWC"), a Public Utility Company organized pursuant to its enabling statute (N.J.S.A. 40:62-108 et seq.), having its principal place of business at 1525 Main Avenue, Clifton, New Jersey 07011, and _____, a professional firm (hereinafter "PROFESSIONAL") having a place of business at _____.

WHEREAS, PVWC desires professional services as applicable, to assist PVWC in its efforts related to Project Number _____ entitled _____ (hereinafter the "PROJECT"); and

WHEREAS, PVWC requires Professional Services to assist it in implementing the PROJECT; and:

WHEREAS, PROFESSIONAL represents that it has the experience and the required professional knowledge to provide the professional services, and/or extraordinary unspecifiable services, as applicable (hereinafter "PROFESSIONAL SERVICES"), and as required by PVWC in this regard as set forth in the Request for Proposals for Professional Services (or Extraordinary Unspecifiable Services), along with a copy of the PROFESSIONAL'S proposal dated _____, 20__, are collectively referred to herein as the "PROPOSAL"; and

WHEREAS, the AGREEMENT shall be for up to a **1,095-day period** of time commencing on the Effective Date of this AGREEMENT as defined in Paragraph 19 herein, and for any extended periods authorized by PVWC.

WHEREAS, PVWC and PROFESSIONAL are desirous of entering into a consulting agreement to cover the PROFESSIONAL SERVICES authorized by PVWC and required for the PROJECT; and

NOW, THEREFORE, in consideration of the mutual promises herein, PVWC and PROFESSIONAL agree that the terms and conditions of this AGREEMENT are the following:

1. PROFESSIONAL shall provide the PROFESSIONAL SERVICES authorized by PVWC and required for the PROJECT. PROFESSIONAL'S obligations under this AGREEMENT are solely for the benefit of PVWC and no other party is intended to benefit or have rights hereunder.
2. PROFESSIONAL shall perform the PROFESSIONAL SERVICES as defined under this AGREEMENT at a level customary for competent and prudent professional service providers, all as applicable, performing such services at the time and place where the services are provided ("STANDARD OF CARE"). These services will be provided by professional service providers in the appropriate disciplines, and by other professionals and individuals skilled in other technical disciplines, as appropriate. PROFESSIONAL shall be responsible for the professional quality, technical accuracy, timely completion and the coordination of all aspects of its services including reports and other deliverables and services provided under this AGREEMENT. The services to be performed by PROFESSIONAL shall conform to the generally accepted codes and regulations applicable to the subject PROJECT. PROFESSIONAL agrees to indemnify and hold PVWC harmless from all losses and damages resulting from PROFESSIONAL'S failure to meet the STANDARD OF CARE. Further, PROFESSIONAL shall correct and re-perform any services not conforming to the required STANDARD OF CARE without additional compensation and cost to PVWC, (including, but not limited to pending written or oral testimony, reports, etc., which might occur from activities resulting from the performance of this AGREEMENT which were caused by PROFESSIONAL'S performance). In addition, PROFESSIONAL shall indemnify and hold harmless PVWC and its officers, agents and employees of PVWC from and against any losses, claims, damages, or liabilities to which PVWC may become subject insofar as and to the extent they arise out of the deviation from the STANDARD OF CARE in the negligent performance of the services by the PROFESSIONAL, hereunder.
3. The cost of services performed by PROFESSIONAL pursuant to this AGREEMENT for PROJECT shall be as stipulated and/or required by PVWC in the **Cost Proposal Worksheet (Form No. 2) in Section VI** of this RFP, shall be in accordance with the PROPOSAL. The Proposal shall include, on a separate page, a schedule of Professional's hourly rates for technical and related support services and non-labor expenses.

PROFESSIONAL shall invoice PVWC its services hereunder after completion thereof and on the basis of reports and accompanying documents, if appropriate, on a monthly basis, including therein information as to progress in performance as against one hundred percent (100%) completion thereof and also showing amounts previously compensated hereunder, as against the total authorization. When the billing amount for actual work performed and costs incurred during the period covered by the invoice is less than \$1,000 the PROFESSIONAL shall add the service and costs to the next billing cycle. To the extent items appearing on invoices presented by PROFESSIONAL are not contested, PVWC will remit payment of the invoice as soon as it can reasonably process same in the normal course of business and barring any failure of systems related thereto or unusual staffing shortages. If at any time it appears to PROFESSIONAL that the proposed scope of services to be performed on the different aspects of any PROJECT will exceed that which was authorized by PVWC, PROFESSIONAL shall clearly indicate same in its continuing written reports. The PROJECT shall be invoiced separately. Each invoice shall include a breakdown of hours expended along with the names of individual

expending said hours, along with a breakdown of charges from subcontractors where applicable and out-of-pocket expenses chargeable to the PROJECT. Each invoice shall include a summary sheet including total amount billed for the time period covered by the invoice and the time period covered, total amount billed to date, total not-to-exceed dollar amount for cost of services (said amounts as set forth or defined in Paragraph 3 herein), and balance remaining.

4. PROFESSIONAL shall be responsible to PVWC for any subcontractors and outside associates or professional it engages to assist it in the performance of the services required under this AGREEMENT.

5. PVWC will provide to PROFESSIONAL all available information, including previous reports, bidding documents and any other data in its possession relevant to the subject PROJECT.

6. Both PVWC and PROFESSIONAL understand that the goal of this AGREEMENT is to complete all phases of the subject PROJECT in a reasonably expeditious fashion. To this end each pledges to the other full cooperation.

7. The services to be performed under this AGREEMENT for the PROJECT shall be deemed to be completed when the scope of work authorized by PVWC for the PROJECT has satisfactorily been fulfilled.

8. By notice in writing at any time, PVWC may change the general scope of services required by PROFESSIONAL as set forth herein. In such event an equitable adjustment, if appropriate, in compensation shall be agreed to in writing prior to PROFESSIONAL'S performing the changed services.

9. PROFESSIONAL shall hold secret and confidential all information designated by PVWC as confidential. PROFESSIONAL shall not reveal any designated confidential information to a third party unless the disclosing party was lawfully possessed with the information before receipt of same from the party claiming confidentiality and whose information has been designated as described herein as being confidential, or applicable law, regulation, court order or any agency of competent jurisdiction requires its disclosure; or the failure to disclose the information would pose an imminent and substantial threat to human health or the environment.

10. PROFESSIONAL shall maintain insurance.

Insurance Coverages

- A. Commercial General Liability: \$2,000,000 Each Occurrence / \$4,000,000 Aggregate (Completed Operations must be included)
- B. Business Automobile Liability: \$2,000,000 combined single limit any one accident (All owned, hired or non-owned automobiles used in connection with this agreement)
- C. Professional Liability/Errors & Omissions Liability: \$5,000,000 each claim / \$5,000,000 annual aggregate (Must not contain cyber, privacy or network-related exclusions)
- D. Workers' Compensation: Statutory
- E. Employers' Liability: \$1,000,000
- F. Crime: \$1,000,000 (Must include Employee Theft and Client Coverage)
- G. Environmental Liability (if applicable): \$5,000,000 Each Act / \$5,000,000 Aggregate
- H. Cyber Liability: \$3,000,000 Each Claim / \$3,000,000 Aggregate
- I. Umbrella/Excess Liability: \$5,000,000 Aggregate

PROFESSIONAL shall provide to the PVWC certificates of insurance as to each of the above which evidence that the policies are in effect.

11. This AGREEMENT shall be interpreted in accordance with the laws of the State of New Jersey and any litigation/arbitration relating to the AGREEMENT shall be venued in New Jersey. In the event of litigation, the parties agree and consent to the action being initiated in the Superior Court of New Jersey, Passaic County.

12. PROFESSIONAL represents that it is an independent professional and not an employee of PVWC.

13. If a dispute or complaint arises concerning this AGREEMENT, PVWC and PROFESSIONAL will negotiate a resolution of the dispute. Should negotiations be unsuccessful, the resolution of the dispute shall be submitted to arbitration in accordance with the current Construction Industry Arbitration Rules of the American Arbitration Association and the arbitration proceeding shall be venued in New Jersey. Any decision rendered by the arbitrators shall be final. Judgment may be entered upon the decision in any court having jurisdiction. The decision shall not be subject to modification or appeal except to the extent permitted by Sections 10 and 11 of the Federal Arbitration

Act (9 U.S.C. 10, 11). Notwithstanding the aforementioned, disputes which have a total value (exclusive of interest) in excess of the dollar amount for cost of services (said dollar amount as stipulated in paragraph 3 herein) shall not be arbitrated but shall be litigated.

14. All notices required or intended under this AGREEMENT may be delivered in person, by facsimile or express mail. All notices shall be effective upon the date of receipt by the parties. Notices shall be delivered or sent to the other party at the address appearing in this AGREEMENT. An address may only be changed by written notice to the other party.

15. During the performance of this contract, the contractor agrees as follows:

a) The contractor or subcontractor, where applicable, will not discriminate against any employee or applicant for employment because of age, race, creed, color, national origin, ancestry, marital status, affectional or sexual orientation and gender identity or expression, disability, nationality or sex. Except with respect to affectional or sexual orientation and gender identity or expression, the contractor will ensure that equal employment opportunity is afforded to such applicants in recruitment and employment, and that employees are treated during employment, without regard to their age, race, creed, color, national origin, ancestry, marital status, affectional or sexual orientation, gender identity or expression, disability, nationality or sex. Such equal employment opportunity shall include but not be limited to the following: employment, upgrading, demotion or transfer; recruitment or recruitment advertising; layoff or termination; rates of pay or other forms of compensation; and selection for training, including apprenticeship. The contractor agrees to post in conspicuous places, available to employees and applicants for employment, notices to be provided by the Public Agency Compliance Officer setting forth the provisions of this nondiscrimination clause.

b) The contractor or subcontractor, where applicable, will, in all solicitations or advertisements for employees placed by or on behalf of the contractor, state that all qualified applicants will receive consideration for employment without regard to age, race, creed, color, national origin, ancestry, marital status, affectional or sexual orientation, gender identity or expression, disability, nationality or sex.

c) The contractor or subcontractor, where applicable, will send to each labor union or representative or workers with which it has a collective bargaining agreement or other contract or understanding, a notice, to be provided by the agency contracting officer advising the labor union or workers' representative of the contractor's commitments under this act and shall post copies of the notice in conspicuous places available to employees and applicants for employment.

d) The contractor or subcontractor, where applicable, agrees to comply with any regulations promulgated by the Treasurer pursuant to N.J.S.A. 10:5-31 et seq. as amended and supplemented from time to time and the Americans with Disabilities Act.

e) The contractor or subcontractor agrees to make good faith efforts to afford equal employment opportunities to minority and women workers consistent with Good faith efforts to meet targeted county employment goals established in accordance with N.J.A.C. 17:27-5.2, or Good faith efforts to meet targeted county employment goals determined by the Division, pursuant to N.J.A.C. 17:27-5.2.

f) The contractor or subcontractor agrees to inform in writing its appropriate recruitment agencies including, but not limited to, employment agencies, placement bureaus, colleges, universities, labor unions, that it does not discriminate on the basis of age, creed, color, national origin, ancestry, marital status, affectional or sexual orientation, gender identity or expression, disability, nationality or sex, and that it will discontinue the use of any recruitment agency which engages in direct or indirect discriminatory practices.

g) The contractor or subcontractor agrees to revise any of its testing procedures, if necessary, to assure that all personal testing conforms with the principles of job-related testing, as established by the statutes and court decisions of the State of New Jersey and as established by applicable Federal law and applicable Federal court decisions.

h) In conforming with the applicable employment goals, the contractor or subcontractor agrees to review all procedures relating to transfer, upgrading, downgrading and layoff to ensure that all such actions are taken without regard to age, creed, color, national origin, ancestry, marital status, affectional or sexual orientation, gender identity or expression, disability, nationality or sex, consistent with the statutes and court decisions of the State of New Jersey, and applicable Federal law and applicable Federal court decisions.

i) The contractor shall submit to the public agency, after notification of award but prior to execution of a goods and services contract, one of the following three documents:

- Letter of Federal Affirmative Action Plan Approval
- Certificate of Employee Information Report
- Employee Information Report Form AA302

j) The contractor and its subcontractor shall furnish such reports or other documents to the Division of Public Contracts Equal Employment Opportunity Compliance as may be requested by the Division from time to time in order to carry out the purposes of these regulations, and public agencies shall furnish such information as may be requested by the Division of Public Contracts Equal

Employment Opportunity Compliance for conducting a compliance investigation pursuant to Subchapter 10 of the Administrative Code at N.J.A.C. 17:27.

16. This AGREEMENT is subject to termination at the conclusion of all of the Contract work, time being of the essence as described herein, unless extended by the mutual agreement of the Parties. PVWC retains the right to terminate the PROFESSIONAL upon 15 days' notice to the PROFESSIONAL, which notice shall be effective when given to the PROFESSIONAL in writing at the PROFESSIONAL'S place of business by way of certified mail return receipt requested and regular mail. No other Notice shall be necessary. Should termination under this Article take place, the PROFESSIONAL shall be entitled to compensation for all authorized Contract work completed satisfactorily to the date of termination. PVWC shall be the sole judge of satisfactory work.

17. This AGREEMENT, including any schedules, attachments and referenced documents, is the entire agreement between PVWC and PROFESSIONAL. Any prior or contemporaneous agreements, promises, negotiations or representations not expressly stated herein are of no force and effect. Any changes to this AGREEMENT shall be in writing and signed by the PVWC and PROFESSIONAL.

18. A waiver or breach of any term, condition or covenant by a party shall not constitute a waiver or breach of any other term, condition or covenant. If any court of competent jurisdiction declares a provision of the AGREEMENT invalid, illegal or otherwise unenforceable, the remaining provisions of the AGREEMENT shall remain in full force and effect.

19. The effective date of this AGREEMENT shall be as of the date set forth hereinabove, or where such date is not indicated, the effective date of the AGREEMENT shall be when the last of the two parties is in full possession of a fully executed AGREEMENT document.

20. PROFESSIONAL'S hourly rates for technical and related support services and non-labor expenses shall be as set forth in the PROPOSAL.

21. PROFESSIONAL understands and agrees that upon submission to PVWC and upon receipt of proper payment as provided for in this AGREEMENT, any reports, data, logs or other information provided to PVWC pursuant to the terms and conditions of this AGREEMENT (and which are not designated in accordance with Paragraph 9 of this AGREEMENT as being confidential) are deemed to be non-proprietary to the extent that PVWC, in its sole discretion, may utilize the information submitted for whatever purposes it deems necessary or desirable without seeking permission from PROFESSIONAL, and without providing any additional compensation to PROFESSIONAL; provided, however, that PVWC shall have sole responsibility for use of such work products in applications for which they may not originally have been intended. Reports, data, logs and other information provided to PVWC by PROFESSIONAL shall become the property of PVWC provided, however, that PROFESSIONAL shall have unrestricted right to their use.

22. PVWC designates the Executive Director, the Director of Engineering, or the General Counsel of the PVWC as its designated representative having authority to give instructions, receive information, define PVWC'S policies, and make decisions with respect to the scope of the work to be performed. PVWC reserves the right to change these designees from time to time and will notify PROFESSIONAL of any change(s) in writing.

23. This AGREEMENT may be executed in several counterparts and all so executed documents shall constitute one agreement, binding on all the parties hereto, notwithstanding that all the parties are not signatory to the original or the same counterpart.

IN WITNESS WHEREOF, the parties hereto have made and executed this AGREEMENT by their duly authorized officers, and have affixed their corporate seals, as of the day and year shown on the cover page.

PROFESSIONAL FIRM

Witness or Attest

Secretary

(Seal)

By: _____
Authorized Signatory

PASSAIC VALLEY WATER COMMISSION

By: _____
LOUIS AMODIO

By: _____
JEFFREY LEVINE

EXHIBIT C

OFFICE OF THE COMPTROLLER

CERTIFICATION OF AVAILABILITY OF FUNDS

It is hereby certified that subject to Commission approval of future Budgets, with respect to multi-budget year contracts, there are or will be sufficient available funds for expenditures to be incurred as result of any contract or commitment to be entered into by Passaic Valley Water Commission as follows:

Description of Project or Contract: Project No. 24-PE-05
"Professional Engineering Service for Development of a Facility Plan for Storage and System Resiliency to Comply with LT2 Rule"
Arcadis

Amount of Project or Contract:

Project No. 24-PE-05
Not to Exceed \$2,722,029.00

1. Acct: # 001-0901-419-95-24
CAPITAL/Reservoir Covers
2. Specific Appropriation to which expenditures will be charged:
CAPITAL – 2024-2027

Other comments: Professional Services Contract

Date of Certification: October 17, 2024

Amount Certified: \$2,722,029.00

Yitzchak Weiss
Comptroller and Chief Financial Officer

YW:lb

RESOLUTION NO. 24-121

PASSAIC VALLEY WATER COMMISSION

**RESOLUTION TO PROCURE LICENSE OF PVWC'S ENTERPRISE
ASSET MANAGEMENT APPLICATIONS**

DATE OF ADOPTION: OCTOBER 23, 2024

Introduced by Commissioner: **RIGO SANCHEZ**

Seconded by Commissioner: **JOSEPH KOLODZIEJ**

WHEREAS, Passaic Valley water Commission ("PVWC") previously procured a Computerized Maintenance Management System (CMMS), in accordance with N.J.S.A. 40A:11-5(dd) relating to proprietary software and the licensing for said CMMS, was procured from Central Square Technologies ("Central Square") of Lake Mary, Florida; and

WHEREAS, the licenses with Central Square are due for renewal by December 4, 2024 for a recommended period of 12-months to provide PVWC with assurance of continuity of service; and

WHEREAS, a copy of the memorandum written by the Director of IT, dated October 10, 2024, recommending the 12-month extension is attached hereto as **Exhibit A**; and

WHEREAS, a copy of Quote No. Q-183197 that includes Central Square's breakdown of applications and related fees, for a total of \$75,000.00, is attached hereto as **Exhibit B**; and

WHEREAS, in accordance with N.J.S.A. 40A:11-12, PVWC may purchase goods or services under contracts entered into on behalf of the State by the Division of Purchase and Property in the Department of the Treasury; and

WHEREAS, PVWC has elected to renew the above-referenced licenses pertaining to PVWC's proprietary software system from Central Square of (the "Awardee") in the amount of \$75,000.00 PVWC's Chief Financial Officer has certified, with respect hereto, that funds are currently available for said purpose and a copy of the said certification is attached hereto and made a part hereof as **Exhibit C**; and

WHEREAS, N.J.S.A. 40A:11-12 of the Local Public Contracts Law provides for the awarding of said contract to the Awardee; and

WHEREAS, the Executive Director, the Director of Engineering, the Director of Purchasing and the Chief Financial Officer have reviewed the above referenced memorandums and concur with the recommendation of the IT Department;

NOW, THEREFORE, BE IT RESOLVED, by Passaic Valley Water Commission, in the County of Passaic, New Jersey:

1. That PVWC hereby awards a 12-month Contract for the renewal of the licenses pertaining to PVWC's proprietary software system to the Awardee in connection with the above-described goods and services in the total amount of \$75,000.00; and
2. That an appropriate official of PVWC, on behalf of PVWC, is hereby authorized and directed to execute the Contract hereby awarded to the Awardee and the Secretary of PVWC to attest to the Contract and such other officers, employees and officials of PVWC are hereby authorized to perform such acts and execute such documents as are necessary to implement the terms and intentions of this Resolution.
3. That this matter shall be advertised as required by New Jersey law, in accordance with an appropriate form of notice, and a copy of this Resolution shall be placed on file and made available for public inspection at the office of the Administrative Secretary of the Passaic Valley Water Commission.

RECORD OF COMMISSION VOTE ON FINAL PASSAGE

| | AYE | NAY | ABSTAIN | ABSENT |
|---------------------------|-----------------|------------|----------------|-----------------|
| SANCHEZ, R. | <u>X</u> | --- | --- | --- |
| COTTON, R. | <u>X</u> | --- | --- | --- |
| DEPADUA, C. | <u>X</u> | --- | --- | --- |
| KOLODZIEJ, J. | <u>X</u> | --- | --- | --- |
| LEVINE, J. | <u>X</u> | --- | --- | --- |
| VAN RENSA LIER, R. | --- | --- | --- | <u>X</u> |
| FRIEND, G. | <u>X</u> | --- | --- | --- |

Adopted at a meeting of Passaic Valley Water Commission.

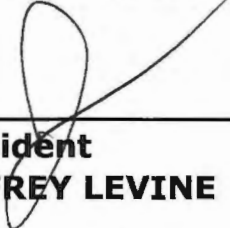

President
JEFFREY LEVINE



Secretary
RUBY N. COTTON

This Resolution, when adopted, must remain in the custody of the Administrative Secretary.

CERTIFICATION

I, LOUIS AMODIO, Administrative Secretary of the Passaic Valley Water Commission in the County of Passaic, and the State of New Jersey do hereby certify that the foregoing Resolution is a true copy thereof of the foregoing Resolution duly passed and adopted by a majority of a legal quorum of the full membership of the Passaic Valley Water Commission at its duly noticed and convened meeting of the said Commission on October 23, 2024.

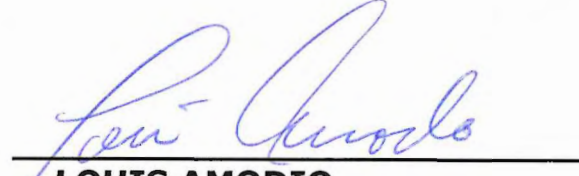

LOUIS AMODIO
Administrative Secretary

EXHIBIT A

Passaic Valley Water Commission Inter – Office Memorandum

To: L. Bresemann
From: L. Ducheine
cc: J. Mueller
Date: October 10, 2024
Re: Recommendation to approve Central Square Annual license for Enterprise Asset Management applications.

The Department of Information Technology recommends the Commission approves Central Square renewal fees for the Enterprise Asset Management software. The provided services are:

| | |
|---|-------------|
| Enterprise Asset Management Bundled on premise site License Annual subscription Fee. | \$75,000.00 |
| Total = | \$75,000.00 |

The requested approval ensures that application is licensed for one year. The Information Technology Dept. recommends that the Board approves the licensing funds request. Our current contract is set to expire in December of 2024. If renewed, the new maintenance contract would be effective for 1 year.

EXHIBIT B



Invoice

Invoice No (1 of 1)
420667

Date
9/24/2024

Page
1 of 2

CentralSquare Technologies, LLC, a CentralSquare Company
1000 Business Center Drive
Lake Mary, FL 32746

Billing Inquiries: Accounts.Receivable@centralsquare.com

Bill To
Passaic Valley Water
Lisa Bresemann
1525 Main Avenue
Clifton NJ 07011
United States

Ship To
Passaic Valley Water
Lisa Bresemann
1525 Main Avenue
Clifton NJ 07011
United States

| Customer No | Customer Name | Customer PO # | Currency | Due Date |
|-------------|----------------------|---------------|----------|-----------|
| 2181LG | Passaic Valley Water | | USD | 12/4/2024 |

| Description | Units | Rate | Extended |
|---|-------|-----------|-----------|
| Quote No. Q-183197 | | | |
| 1 Enterprise Asset Management Bundled-On Premise Site License Annual Subscription - Annual Subscription Fee Maintenance: Start:12/5/2024, End: 12/4/2025 | 1 | 75,000.00 | 75,000.00 |
| 2 Asset Management - Asset Subscription Option SaaS Annual Subscription Fee - Annual Subscription Fee Maintenance: Start:12/5/2024, End: 12/4/2025 | 1 | 0.00 | 0.00 |
| 3 Asset Management - Work Subscription Option SaaS Annual Subscription Fee - Annual Subscription Fee Maintenance: Start:12/5/2024, End: 12/4/2025 | 1 | 0.00 | 0.00 |
| 4 Asset Management - GIS Desktop Subscription Option SaaS Annual Subscription Fee - Annual Subscription Fee Maintenance: Start:12/5/2024, End: 12/4/2025 | 1 | 0.00 | 0.00 |
| 5 Asset Management - GIS Web Subscription Option SaaS Annual Subscription Fee - Annual Subscription Fee Maintenance: Start:12/5/2024, End: 12/4/2025 | 1 | 0.00 | 0.00 |
| 6 Asset Management - Mobile Subscription Option SaaS Annual Subscription Fee - Annual Subscription Fee Maintenance: Start:12/5/2024, End: 12/4/2025 | 1 | 0.00 | 0.00 |
| 7 Asset Management - Citizen Portal Subscription SaaS Annual Subscription Fee - Annual Subscription Fee Maintenance: Start:12/5/2024, End: 12/4/2025 | 1 | 0.00 | 0.00 |
| 8 Asset Management - Rest API's Subscription SaaS Annual Subscription Fee - Annual Subscription Fee Maintenance: Start:12/5/2024, End: 12/4/2025 | 1 | 0.00 | 0.00 |



Invoice

Invoice No (1 of 1)
420667

Date
9/24/2024

Page
2 of 2

CentralSquare Technologies, LLC, a CentralSquare
Company
1000 Business Center Drive
Lake Mary, FL 32746

Billing Inquiries: Accounts.Receivable@centralsquare.com

Bill To
Passaic Valley Water
Lisa Bresemann
1525 Main Avenue
Clifton NJ 07011
United States

Ship To
Passaic Valley Water
Lisa Bresemann
1525 Main Avenue
Clifton NJ 07011
United States

| Customer No | Customer Name | Customer PO # | Currency | Due Date |
|-------------|----------------------|---------------|----------|-----------|
| 2181LG | Passaic Valley Water | | USD | 12/4/2024 |

Please include invoice number(s) on your remittance advice.

ACH:
Routing Number 121000358
Account Number 1416612641
E-mail payment details to: Accounts.Receivable@CentralSquare.com

Check:
12709 Collection Center Drive
Chicago, IL 60693

| | |
|-------------------------|----------------------|
| Subtotal | 75,000.00 |
| Tax | 0.00 |
| Invoice Total | 75,000.00 |
| Payments Applied | 0.00 |
| Balance Due | USD 75,000.00 |

EXHIBIT C

OFFICE OF THE COMPTROLLER

CERTIFICATION OF AVAILABILITY OF FUNDS

It is hereby certified that subject to Commission approval of future Budgets, with respect to multi-budget year contracts, there are or will be sufficient available funds for expenditures to be incurred as result of any contract or commitment to be entered into by Passaic Valley Water Commission as follows:

Description of Project or Contract: Annual Subscription Licensing Fee – Central Square Enterprise Asset Management Bundled On-Premise Site License for Annual Subscription For CMMS Software

Amount of Project or Contract: \$75,000.00

1. Account # 001-0604-416-70-52
IT: Purchases/Maintenance & Licensing Agreements
2. Specific appropriation to which expenditures will be charged:
BUDGET – 2024/2025

Other comments: Twelve (12) Month Contract Commencing December 4, 2024

Date of Certification: October 16, 2024

Amount Certified: \$75,000.00

Yitzchak Weiss
Comptroller and Chief Financial Officer

YW:lb

RESOLUTION NO. 24-123

RESOLUTION OF PASSAIC VALLEY WATER COMMISSION

RESOLUTION FOR BUDGET AMENDMENT, CHANGE ORDER NO. 2 FOR CONTRACT NO. 22-B-14 ENTITLED "EMERGENCY WATER MAIN REPAIRS"

DATE OF ADOPTION: OCTOBER 23, 2024

Introduced by Commissioner: **RIGO SANCHEZ**

Seconded by Commissioner: **JOSEPH KOLODZIEJ**

WHEREAS, PVWC awarded Award Contract No. 22-B-14 entitled "Emergency Water Main Repairs" (the "Contract") to J. Fletcher Creamer & Sons, Inc. ("Creamer") of Hackensack, New Jersey at PVWC's Commission Meeting on June 22, 2022, not to exceed \$4,108,513.00 under Resolution No. 22-066; and

WHEREAS, Change Order No. 1 was to cover out-of-scope emergency work for locating leak on multiples and installation of a structural liner on four (4) of the failed / problematic water mains crossing the Passaic River at Belleville and Kearny, with a total increase of \$1,250,000.00 (30.4% increase) which brought the total adjusted Contract Price up to \$5,358,513.00; and

WHEREAS, Change Order No. 2 is to cover out-of-scope emergency work on several major breaks on large-diameter transmission mains, with one break located within an environmentally contaminated site, two ongoing repairs due to the complex nature of the repairs and the job site, with a total increase of \$1,800,000.00 (74.2% increase) which brings the total adjusted Contract Price up to \$7,158,513.00; and

WHEREAS, the Chief Engineer has reviewed Creamer's Proposals for ongoing work and emergency expenditures already performed by Creamer and found it to be reasonable, considering the nature and scope of additional Work involved, and has recommended that the said changes to the Project, and additional costs related thereto, be approved, and a copy of the memorandum dated October 16, 2024 recommending approval of the said changes to the Project is attached hereto and made a part hereof as **Exhibit A**; and

WHEREAS, PVWC's Chief Financial Officer has certified, with respect hereto, that funds are currently available for said purpose and a copy of the said certification is attached hereto and made a part hereof as **Exhibit B**.

NOW, THEREFORE, BE IT RESOLVED, by Passaic Valley Water Commission, in the County of Passaic, New Jersey:

1. That PVWC hereby approves Change Order No. 2 and awards the changes to the scope of Work as set forth hereinabove; and
2. That the appropriate officials of PVWC, and such other officers, employees and officials of PVWC, on behalf of PVWC, are hereby authorized to execute and enter into the said Amendment to the Agreement, and to perform such other acts and execute such documents as are necessary to implement the terms and intentions of this Resolution; and
3. That this matter shall be advertised as required by New Jersey law, in accordance with an appropriate form of notice, and a copy of this Resolution shall be placed on file and made available for inspection at the office of the Administrative Secretary of Passaic Valley Water Commission.

RECORD OF COMMISSION VOTE ON FINAL PASSAGE

| | AYE | NAY | ABSTAIN | ABSENT |
|---------------------------|-----------------|------------|----------------|-----------------|
| VAN RENSA LIER, R. | — | — | — | <u>X</u> |
| COTTON, R. | <u>X</u> | — | — | — |
| SANCHEZ, R. | <u>X</u> | — | — | — |
| KOLODZIEJ, J. | <u>X</u> | — | — | — |
| DEPADUA, C. | <u>X</u> | — | — | — |
| FRIEND, G. | <u>X</u> | — | — | — |
| LEVINE, J. | <u>X</u> | — | — | — |

Adopted at a meeting of Passaic Valley Water Commission.



President
JEFFREY LEVINE



Secretary
RUBY N. COTTON

This Resolution, when adopted, must remain in the custody of the Administrative Secretary.

CERTIFICATION

I, LOUIS AMODIO, Administrative Secretary of the Passaic Valley Water Commission in the County of Passaic, and the State of New Jersey do hereby certify that the foregoing Resolution is a true copy thereof of the foregoing Resolution duly passed and adopted by a majority of a legal quorum of the full membership of the Passaic Valley Water Commission at its duly noticed and convened meeting of the said Commission on October 23, 2024.

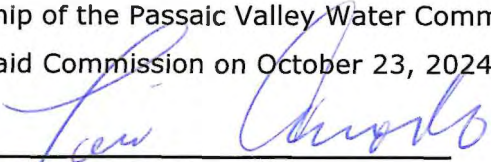

LOUIS AMODIO
Administrative Secretary

EXHIBIT A

**PASSAIC VALLEY WATER COMMISSION
INTEROFFICE MEMORANDUM**

Date: October 16, 2024

To: J. Mueller

From: P. Porcaro

cc: C. Vozzella, A. Wells, L. Bresemann, Y. Weiss

Re: Resolution No. 24-123: Change Order No. 2 for Contract No. 22-B-14 Entitled "Emergency Water Main Repairs"

Contract No. 22-B-14 entitled "Emergency Water Main Repairs" was awarded to J. Fletcher Creamer & Sons, Inc. (Creamer) of Hackensack, New Jersey at PVWC's Commission Meeting dated June 22, 2022 (PVWC Resolution 22-066), and with reimbursement not to exceed \$4,108,513.00. Amendment 1 revised the not-to-exceed total price of \$5,358,513.00 at the May 24, 2023 Commission meeting to rehabilitate the defunct Kearny multiples.

A series of major breaks on several transmission mains occurred from May 20 to September 20, 2024 with two repairs ongoing due to the complex nature of the repairs as summarized below:

1. 24-inch main at 1 Market Street in Elmwood Park.
2. 16/30-inch at Shady Lane and Lowe Street in Paterson
3. 24-inch main at 21st Avenue and Spring Street
4. 51-inch at 1425 Broad Street in Clifton
5. 20-in at Main Avenue and Sylvan Street ongoing due to severe encroachments and lead time of structural liner at culvert crossing.
6. 42-inch at 68 N 1st Street in Paterson

Proposed Change Order No. 2 increases the Contract Price by an additional \$1,800,000 (74.2% total increase) which brings the total adjusted Contract Price to \$7,158,513.00.

EXHIBIT B

OFFICE OF THE COMPTROLLER

CERTIFICATION OF AVAILABILITY OF FUNDS

It is hereby certified that subject to Commission approval of future Budgets, with respect to multi-budget year contracts, there are or will be sufficient available funds for expenditures to be incurred as result of any contract or commitment to be entered into by Passaic Valley Water Commission as follows:

Description of Project or Contract: Contract No. 22-B-14 – Change Order No. 2
“Emergency Water Main Repairs”
J. Fletcher Creamer & Sons, Inc.

Amount of Project or Contract:

Contract No. 22-B-14
Increase of \$1,800,000.00
Not to Exceed \$7,158,513.00

1. Acct: # 001-0901-419-95-17
CAPITAL/Main Breaks
2. Specific Appropriation to which expenditures will be charged:
CAPITAL – 2024/2025

Other comments: Change Order Number 2 – Increase of \$1,800,000.00
for a New Not-to-Exceed of \$7,158,513.00

Date of Certification: October 17, 2024

Amount Certified: \$7,158,513.00

Yitzchak Weiss
Comptroller and Chief Financial Officer

YW:lb

RESOLUTION # 24-124

RESOLUTION OF PASSAIC VALLEY WATER COMMISSION

RESOLUTION FOR A TIME EXTENSION FOR PROJECT NO. 21-P-81 ENTITLED "ENGINEERING SERVICES TO PRODUCE A MASTER FACILITY PLAN FOR LFWTP INCLUDING PLACEMENT OF NEW FINISHED WATER MAIN PUMP STATION"

DATE OF ADOPTION: OCTOBER 23, 2024

Introduced by Commissioner: RIGO SANCHEZ

Seconded by Commissioner: JOSEPH KOLODZIEJ

WHEREAS, Passaic Valley Water Commission ("PVWC") has solicited and awarded for professional services (or extraordinary unspecifiable services) Project No. 21-P-81 entitled "Engineering Services to Produce a Master Facility Plan for LFWTP including Placement of New Finished Water Main Pump Station" (hereinafter the "Project") under Resolution 21-106 on December 16, 2021, to MacDonald LLC ("Mott"), of Iselin, New Jersey, with said solicitation and procurement of responses (and evaluation of same) undertaken through a fair and open process, as defined in N.J.S.A. 19:44A-20.7 (hereinafter the "Fair and Open Process"); and

WHEREAS, Mott has, and continues to, provide professional services related to the Project consistently, reliably, efficiently, and effectively on an as-needed basis; and

WHEREAS, the PVWC has requested for the firm to assist with the Facility Master Plan for the Little Falls Water Treatment Plant ("LFWTP") by Black & Veatch under Contract No. 24-PE-04; and

WHEREAS, work shall include providing 3D laser scanning of all buildings with process equipment to develop record drawings of the Commission's assets and producing an detailed Asset Management Plan for the LFWTP; and

WHEREAS, under the Local Public Contracts Law N.J.S.A. 40A:11-1 et seq. as amended April 17, 2000 (the "Act"), certain discretionary provisions enabled under said Act, including extensions to existing contracts pursuant to N.J.S.A. 40A:11-15 (16) (the LCPL), were subsequently adopted by PVWC; and

WHEREAS, the PVWC seeks a non-compensatory time extension for the Project thereby setting a new expiration date of February 22, 2026; and

WHEREAS, the Chief Engineer has recommended that the said changes to the Project be approved and a copy of the memorandum dated October 16, 2024 recommending approval of the said changes to the Project is attached hereto and made a part hereof as **Exhibit A**; and

NOW, THEREFORE, BE IT RESOLVED, by Passaic Valley Water Commission, in the County of Passaic, New Jersey:

1. That PVWC hereby authorizes and awards a contract extension to the terms as set forth hereinabove; and
2. That appropriate officers of the Commission are hereby authorized and directed to execute this Contract extension as set forth hereinabove and implement the terms of this extended Contract in accordance with this Resolution and the submissions provided in connection herewith, and the Secretary of PVWC to attest to this Contract extension and such other officers, employees and officials of PVWC are hereby authorized to perform such acts and execute such documents as are necessary to implement the terms and intentions of this Resolution; and
3. That this matter shall be advertised as required by New Jersey law, in accordance with an appropriate form of notice, and a copy of this Resolution shall be placed on file and made available for public inspection at the office of the Administrative Secretary of Passaic Valley Water Commission.

RECORD OF COMMISSION VOTE ON FINAL PASSAGE

| | AYE | NAY | ABSTAIN | ABSENT |
|---------------------------|--------------|------------|----------------|---------------|
| VAN RENSA LIER, R. | <u> X </u> | — | — | <u> X </u> |
| COTTON, R. | — | — | — | — |
| SANCHEZ, R. | <u> X </u> | — | — | — |
| KOLODZIEJ, J. | <u> X </u> | — | — | — |
| DEPADUA, C. | <u> X </u> | — | — | — |
| FRIEND, G. | <u> X </u> | — | — | — |
| LEVINE, J. | <u> X </u> | — | — | — |

Adopted at a meeting of Passaic Valley Water Commission.

President
JEFFREY LEVINE

Secretary
RUBY N. COTTON

This Resolution, when adopted, must remain in the custody of the Administrative Secretary.

CERTIFICATION

I, LOUIS AMODIO, Administrative Secretary of the Passaic Valley Water Commission in the County of Passaic, and the State of New Jersey do hereby certify that the foregoing Resolution is a true copy thereof of the foregoing Resolution duly passed and adopted by a majority of a legal quorum of the full membership of the Passaic Valley Water Commission at its duly noticed and convened meeting of the said Commission on October 23, 2024.

LOUIS AMODIO
Administrative Secretary

EXHIBIT A

**PASSAIC VALLEY WATER COMMISSION
INTEROFFICE MEMORANDUM**

Date: October 16, 2024

To: J. Mueller

From: P. Porcaro

cc: C. Vozzella, J. Alesandrelli, L. Bresemann, Y. Weiss

Re: Resolution No. 24-124: Time Extension for Project 21-P-81 Entitled "Engineering Services to Produce a Master Facility Plan for LFWTP including Placement of New Finished Water Main Pump Station"

Project No. 21-P-81 entitled "Engineering Services to Produce a Master Facility Plan for LFWTP including Placement of New Finished Water Main Pump Station" was awarded to Mott MacDonald LLC (Mott), of Iselin, New Jersey at PVWC's December 16, 2021 Commission Meeting (Resolution No. 21-106) not to exceed \$1,841,118.00.

We recommend a time extension to February 22, 2026 for the firm to assist with the Facility Master Plan for the Plant by Black & Veatch under Contract No. 24-PE-04. Work shall include 3D laser scanning all buildings with process equipment to develop record drawings of the Commission's assets and producing an detailed Asset Management Plan for the LFWTP.

RESOLUTION # 24-125

RESOLUTION OF PASSAIC VALLEY WATER COMMISSION

RESOLUTION TO APPROVE CHANGE ORDER NO. 1 AND TIME EXTENSION FOR PROJECT NO. 20-P-83 ENTITLED "PROFESSIONAL SERVICES FOR PATERSON MAIN REPLACEMENT"

DATE OF ADOPTION: OCTOBER 23, 2024

Introduced by Commissioner: **RIGO SANCHEZ**

Seconded by Commissioner: **JOSEPH KOLODZIEJ**

WHEREAS, PVWC awarded Contract No. 20-P-83 entitled "Professional Services for Paterson Main Replacement" (the "Project") to Remington & Vernick Engineers ("RVE") of Haddonfield, New Jersey at PVWC's Commission Meeting on June 10, 2020 all in accordance with N.J.S.A. 40A:11-15; and in an amount not to exceed \$846,692.50; and

WHEREAS, RVE has been performing construction management support for overseeing work performed by Grade Construction of Paterson, New Jersey under Contract No. 22-B-07; and

WHEREAS, it is recommended that PVWC issues Change Order No. 1 to continue support for the duration of said contract and increase the Contract Price with an additional increase of \$420,000.00 which brings the total adjusted Contract Price up to \$1,266,692.50; and

WHEREAS, the Chief Engineer has reviewed RVE's Proposal dated October 4, 2024 for ongoing work and work already performed, attached hereto and made a part hereof as **Exhibit A** and found it to be reasonable, considering the nature and scope of additional Work involved; and

WHEREAS, the PVWC seeks a non-compensatory time extension for the Project thereby setting a new expiration date of April 30, 2025; and

WHEREAS, it is recommended that the said changes to the Project, and additional costs related thereto, be approved, and a copy of the memorandum dated October 16, 2024 recommending approval of the said changes to the Project is attached hereto and made a part hereof as **Exhibit B**; and

WHEREAS, PVWC's Chief Financial Officer has certified, with respect hereto, that funds are currently available for said purpose and a copy of the said certification is attached hereto and made a part hereof as **Exhibit C**.

NOW, THEREFORE, BE IT RESOLVED, by Passaic Valley Water Commission, in the County of Passaic, New Jersey:

1. That PVWC hereby authorizes Change Order No. 1 and contract extension to the terms as set forth hereinabove; and
2. That appropriate officers of the Commission are hereby authorized and directed to execute this Contract extension as set forth hereinabove and implement the terms of this extended Contract in accordance with this Resolution and the submissions provided in connection herewith, and the Secretary of PVWC to attest to this Contract extension and such other officers, employees and officials of PVWC are hereby authorized to perform such acts and execute such documents as are necessary to implement the terms and intentions of this Resolution; and
3. That this matter shall be advertised as required by New Jersey law, in accordance with an appropriate form of notice, and a copy of this Resolution shall be placed on file and made available for public inspection at the office of the Administrative Secretary of Passaic Valley Water Commission.

RECORD OF COMMISSION VOTE ON FINAL PASSAGE

| | AYE | NAY | ABSTAIN | ABSENT |
|---------------------------|-----------------|------------|----------------|-----------------|
| VAN RENSA LIER, R. | — | — | — | <u>X</u> |
| COTTON, R. | <u>X</u> | — | — | — |
| SANCHEZ, R. | <u>X</u> | — | — | — |
| KO LODZIEJ, J. | <u>X</u> | — | — | — |
| DE PADUA, C. | <u>X</u> | — | — | — |
| FRIEND, G. | <u>X</u> | — | — | — |
| LEVINE, J. | <u>X</u> | — | — | — |

Adopted at a meeting of Passaic Valley Water Commission.



President
JEFFREY LEVINE

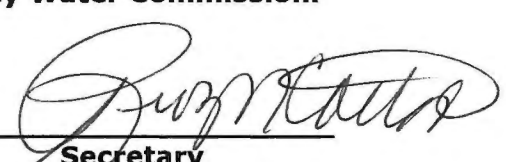

Secretary
RUBY N. COTTON

This Resolution, when adopted, must remain in the custody of the Administrative Secretary.

CERTIFICATION

I, LOUIS AMODIO, Administrative Secretary of the Passaic Valley Water Commission in the County of Passaic, and the State of New Jersey do hereby certify that the foregoing Resolution is a true copy thereof of the foregoing Resolution duly passed and adopted by a majority of a legal quorum of the full membership of the Passaic Valley Water Commission at its duly noticed and convened meeting of the said Commission on October 23, 2024.



LOUIS AMODIO
Administrative Secretary

EXHIBIT A

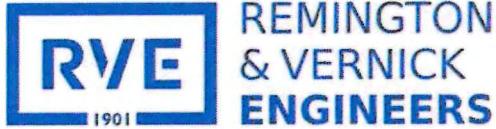

One Harmon Plaza, Suite 210
Secaucus, NJ 07094
O: (201) 624-2137
F: (201) 624-2136

October 4, 2024

Patrick Porcaro, P.E., Director of Engineering
Passaic Valley Water Commission
1525 Main Avenue
Clifton, NJ 07011

**RE: Proposal to Provide Consulting Engineering Services
Paterson Water Main Replacement – Change of Scope #1
PVWC Project No. 20-P-83 / 22-B-7
RVE File No. 3797X030**

Dear Mr. Porcaro:

As you are aware, in 2020 the Passaic Valley Water Commission (PVWC) authorized Remington & Vernick Engineers (RVE) to provide engineering services for replacement of water mains in the City of Paterson (PVWC Contract No. 20-P-83). As RVE was proceeding with the design work on this project, PVWC became aware of several exigent improvements needed to their system in advance of the planned abandonment of the Levine finished water reservoir. These improvements included (all elements are located in Paterson):

1. Replacement of a 48-inch water main in 21st Avenue;
2. Installation of an interconnection on 21st Avenue to connect their high- and low-pressure loops;
3. Repair and structural lining of a 36-inch main at the Levine Reservoir and abandonment of the reservoir inlet/outlet pipe; and
4. Installation of a 16-inch pressure relief valve and chamber on Totowa Avenue.

As a result of this need, in April 2021 RVE was directed by PVWC to pause on the design of the Paterson water main replacements until the Levine Tank work was complete. The All elements of the remaining budget were diverted into the new work. RVE completed the new design and delivered plans and specs to PVWC for bidding in March 2022. The Contract (PVWC Contract No. 22-B-7) was awarded to the low bidder - Grade Construction of Paterson, NJ, who was granted a Notice to Proceed in July 2022. Since that time, RVE has been conducting construction management / construction inspection (CM/CI) of Grade's work on the contract.

At this point in time; the original RVE budget of \$846,692.50 has been exhausted, and in in need of increase in order for us to complete our construction oversight of Grade. Grade has been an extraordinarily difficult contractor, requiring close oversight of and pushback against both their field crews and project management personnel. The original Contract Completion Date for the work was July 14, 2023; the current estimated Project Completion date is approximately April 25, 2025. The following is a partial list of events (primarily but not exclusively by Grade) that have caused the project to greatly exceed the planned 365-day construction period:

1. Grade was very slow and sporadic with their shop drawing submittals – while the first submittals were received and approved in August 2022, submittals were still being received by RVE into mid-2023.
2. Grade was slow to mobilize for work; Despite the Notice to Proceed being issued on July 15, 2022, Grade did not mobilize to the site to begin work until February 21, 2023.
3. In April 2023, Grade's crew damaged an unmarked NJDOT conduit in 21st Avenue (NJDOT is apparently not part of the NJ One-Call system, and all parties were unaware of the fact that all of

21st Avenue (a City of Paterson road) was entirely NJDOT Right-of-Way. When NJDOT met with Grade on site shortly after the incident, Grade's exceedingly defensive and negative responses caused the NJDOT to close down the job and require an NJDOT permit for the work. Informally, NJDOT personnel have noted to PVWC that if Grade were cooperative in fixing the conduit, the project would not have been shut down.

4. The NJDOT shutdown continued for nearly a year, with NJDOT requiring multiple rounds of submissions and responding very slowly to RVE and PVWC inquiries. Finally, in February 2024, after a change in application reviewer, NJDOT reversed course and stated that a permit was not necessary.
5. Despite the NJDOT issue being resolved in February 2024, Grade did not remobilize to the site to resume work until May 9. This was partially due to a homeless encampment that was established during the NJDOT shutdown and required a coordinated effort with the City of Paterson to remove.
6. Grade has been contentious on the project, with more than 25 proposed change orders (PCO's) submitted to date, requiring significant review and response time on the part of RVE. Over half of the PCO's have been rejected as covered under the Contract Scope, and several others have been significantly reduced in cost. Several PCO's remain outstanding, including some major delay claims by Grade.
7. To date, three Change Orders to the Contract have been approved by PVWC, for a total amount of \$289,962.40.
8. On June 19, 2024, Grade caused a break in an existing 24-inch main in PVWC's high pressure loop. The break required the assistance of PVWC's emergency contractor and involved approximately 30 hours of round-the clock inspection by RVE, as well as significant additional time for investigation and restoration.
9. Grade has been cited several times for unsafe and unsanitary conditions on site, with open pipe resulting in sediment entry into the main. This has required efforts by both RVE's inspectors and PM to ensure that situations were corrected by Grade.
10. There has been significant back-and-forth between Grade, RVE and PVWC's SCADA personnel regarding the instrumentation panels to be provided as a part of the project. Much progress has been made in resolving these issues; however, all parties are still working towards full resolution.

In addition to Grade-caused incidents, there have been several other issues and requests that arose on the project that required additional time on the part of RVE personnel:

11. As the project proceeded, several unmarked or mismarked sewer lines (both sanitary and storm) were discovered in locations that impacted the proposed work and necessitated relocation or replacement of the sewer lines. This entailed significant expenditure of RVE time for investigation and redesign.
12. At the Levine Reservoir, a large amount of concrete was found surrounding the 3-6 inch main to be lined. Initial efforts to jackhammer the concrete raised concerns with PVWC regarding the structural integrity of the pipe, so work was suspended until the work on 21st Avenue is completed and the reservoir inlet/outlet pipe isolated.
13. During installation of the Interconnection Chamber, a hydrocarbon odor was noted in the excavated material. RVE had the material tested, and it was found to be non-hazardous, but requiring disposal under NJ ID-127 standards.

14. Recently, PVWC asked RVE to perform some hydraulic modeling of the proposed system improvements to determine if interim storage would be required at the Levine Reservoir during the construction of the replacement tanks. This work was performed by RVE personnel under this contract, and determined that interim storage is not necessary.

As noted above, the original RVE budget for the Paterson Water Main Replacement project was \$846,692.00. All unexpended budget as of May 2020 was diverted to the Levine work. Expenditures to date (9/30/2024) are as follows (number are rounded for convenience):

| | | |
|------|--|------------------|
| i. | Paterson Water Main Replacement investigations and partial design | \$221,000 |
| ii. | Levine Industrial Loop Improvements design (complete) | \$244,000 |
| iii. | Bidding, Contracts and submittal reviews | \$ 17,000 |
| iv. | Construction Management / Construction Inspection (excluding NJDOT delay) | \$345,000 |
| v. | Activities during NJDOT delay | \$ 75,000 |
| | TOTAL | \$902,000 |

Based upon RVE's current rate of expenditures, and the anticipated time to contract completion (April 2025), we estimate an additional not-to-exceed budget of \$420,000 will be sufficient to complete the scope of the project. This will result in a revised project budget of \$1,266,692.50

As per recent conversations with PVWC, RVE understands that the Paterson Water Main work will not proceed. The project design is approximately 35% complete; RVE will compile all files related to the design and forward to PVWC for their records.

Should you have any questions or require additional regarding this project or the above information, please do not hesitate to contact Mark Hubal at (609) 760-0543.

Sincerely,

REMINGTON & VERNICK ENGINEERS



Stephanie Cuthbert, PE, CME
Principal | Water & Wastewater Division Manager

Cc: Jaro Adamkiewicz, PVWC
Alex Wells, PVWC
Mark A. Hubal, RVE
Timothy Marques, RVE

EXHIBIT B

**PASSAIC VALLEY WATER COMMISSION
INTEROFFICE MEMORANDUM**

Date: October 16, 2024

To: J. Mueller

From: P. Porcaro

cc: C. Vozzella, A. Wells, L. Bresemann, Y. Weiss

Re: Resolution No. 24-125: Change Order No. 1 and Time Extension for Project 20-P-83 Entitled "Professional Services for Paterson Main Replacement"

Project No. 20-P-83 entitled "Professional Services for Paterson Main Replacement" was awarded to Remington & Vernick Engineers (RVE), of Haddonfield, New Jersey at PVWC's June 10, 2020, Commission Meeting with a not to exceed amount of \$846,692.50.

RVE has been performing construction management support for overseeing work performed by Grade Construction of Paterson, New Jersey under Contract No. 22-B-07 for performing advanced work to the Industrial Loop, Levine Reservoir inlet and surge relief on the 51—inch prior to the execution of the Levine Tanks Contract.

Grade has been an extraordinarily difficult contractor, requiring close oversight of and pushback against both their field crews and project management personnel. The original Contract Completion Date for the work was July 14, 2023; the current estimated Project Completion date is approximately April 25, 2025. The following is a partial list of events (primarily but not exclusively by Grade) that have caused the project to greatly exceed the planned 365-day construction period:

1. Grade was very slow and sporadic with their shop drawing submittals – while the first submittals were received and approved in August 2022, submittals were still being received by RVE into mid-2023.
2. Grade was slow to mobilize for work; Despite the Notice to Proceed being issued on July 15, 2022, Grade did not mobilize to the site to begin work until February 21, 2023.
3. In April 2023, Grade's crew damaged an unmarked NJDOT conduit in 21st Avenue (NJDOT is apparently not part of the NJ One-Call system, and all parties were unaware of the fact that all of 21st Avenue (a City of Paterson Road) was entirely NJDOT Right-of-Way. When NJDOT met with Grade on site shortly after the incident, Grade's exceedingly defensive and negative responses caused the NJDOT to close down the job and require an NJDOT permit for the work. Informally, NJDOT personnel have noted to PVWC that if Grade were cooperative in fixing the conduit, the project would not have been shut down.
4. The NJDOT shutdown continued for nearly a year, with NJDOT requiring multiple rounds of submissions and responding very slowly to RVE and PVWC inquiries. Finally, in February 2024, after a change in application reviewer, NJDOT reversed course and stated that a permit was not necessary.
5. Despite the NJDOT issue being resolved in February 2024, Grade did not remobilize to the site to resume work until May 9. This was partially due to a homeless encampment that was established during the NJDOT shutdown and required a coordinated effort with the City of Paterson to remove.
6. Grade has been contentious on the project, with more than 25 proposed change orders (PCO's) submitted to date, requiring significant review and response time on the part of RVE. Over half of the PCO's have been rejected as covered under the Contract Scope, and several others have been significantly reduced in cost. Several PCO's remain outstanding, including some major delay claims by Grade.
7. On June 19, 2024, Grade caused a break in an existing 24-inch main in PVWC's high pressure loop. The break required the assistance of PVWC's emergency contractor and involved approximately 30 hours of round-the clock inspection by RVE, as well as significant additional time for investigation and restoration.
8. Grade has been cited several times for unsafe and unsanitary conditions on site, with open pipe resulting in sediment entry into the main. This has required efforts by both RVE's inspectors and PM to ensure that situations were corrected by Grade.
9. There has been significant back-and-forth between Grade, RVE and PVWC's SCADA personnel regarding the instrumentation panels to be provided as a part

of the project, Much progress has been made in resolving these issues; however, all parties are still working towards full resolution.

In addition to Grade-caused incidents, there have been several other issues and requests that arose on the project that required additional time on the part of RVE personnel:

1. As the project proceeded, several unmarked or mismarked sewer lines (both sanitary and storm) were discovered in locations that impacted the proposed work and necessitated relocation or replacement of the sewer lines. This entailed significant expenditure of RVE time for investigation and redesign.
2. At the Levine Reservoir, a large amount of concrete was found surrounding the 36-inch main to be lined. Initial efforts to jackhammer the concrete raised concerns with PVWC regarding the structural integrity of the pipe, so work was suspended until the work on 21st Avenue is completed and the reservoir inlet/outlet pipe isolated.
3. During installation of the Interconnection Chamber, a hydrocarbon odor was noted in the excavated material. RVE had the material tested, and it was found to be non-hazardous, but requiring disposal under NJ ID-127 standards.
4. Recently, PVWC asked RVE to perform some hydraulic modeling of the proposed system improvements to determine if interim storage would be required at the Levine Reservoir during the construction of the replacement tanks. This work was performed by RVE personnel under this contract and determined that interim storage is not necessary.

Proposed Change Order No. 1 increases the Contract Price by an additional \$420,000.00 which brings the total adjusted Contract Price to \$1,266,692.50 and a time extension to April 30, 2025.

EXHIBIT C

OFFICE OF THE COMPTROLLER

CERTIFICATION OF AVAILABILITY OF FUNDS

It is hereby certified that subject to Commission approval of future Budgets, with respect to multi-budget year contracts, there are or will be sufficient available funds for expenditures to be incurred as result of any contract or commitment to be entered into by Passaic Valley Water Commission as follows:

Description of Project or Contract: Project No. 20-P-83 – Change Order No. 1
“Professional Services for Paterson Main Replacement”
Remington & Vernick Engineers

Amount of Project or Contract:

Project No. 20-P-83
Increase of \$420,000.00
Not to Exceed \$1,266,692.50

1. Acct: # 001-0901-419-95-17
CAPITAL/Transmission Mains/Pipes
2. Specific Appropriation to which expenditures will be charged:
CAPITAL – 2024/2025

Other comments: Change Order Number 1 – Increase of \$420,000.00
for a New Not-to-Exceed of \$1,266,692.50

Date of Certification: October 17, 2024

Amount Certified: \$1,266,692.50

Yitzchak Weiss
Comptroller and Chief Financial Officer

YW:lb

RESOLUTION # 24-126

RESOLUTION OF PASSAIC VALLEY WATER COMMISSION

**RESOLUTION FOR A TIME EXTENSION FOR PROJECT NO. 20-P-91 ENTITLED
"PROFESSIONAL SERVICES FOR FERC REGULATORY-REQUIRED IMPROVEMENTS TO
PVWC'S INTAKE CANAL FACILITIES AND INTERFACING WITH PROJECT 15-P-41"**

DATE OF ADOPTION: OCTOBER 23, 2024

Introduced by Commissioner: **RIGO SANCHEZ**

Seconded by Commissioner: **JOSEPH KOLODZIEJ**

WHEREAS, Passaic Valley Water Commission ("PVWC") has solicited and awarded for professional services (or extraordinary unspecifiable services) Project No. 20-P-91 entitled "Professional Services for FERC Regulatory-Required Improvements to PVWC's Intake Canal Facilities and Interfacing with Project 15-P-41" (hereinafter the "Project") under Resolution 21-33 on March 10, 2021, to Ramboll Americas Engineering ("Ramboll") of Princeton, New Jersey, with said solicitation and procurement of responses (and evaluation of same) undertaken through a fair and open process, as defined in N.J.S.A. 19:44A-20.7 (hereinafter the "Fair and Open Process"); and

WHEREAS, Ramboll has, and continues to, provide professional services related to the Project consistently, reliably, efficiently, and effectively on an as-needed basis; and

WHEREAS, the PVWC has requested the firm to complete all required site investigations and develop a Basis of Design Report for the rehabilitation of the PVWC's Intake Canal, Headgates and Screenhouse Facilities at the LFWTP; and

WHEREAS, under the Local Public Contracts Law N.J.S.A. 40A:11-1 et seq. as amended April 17, 2000 (the "Act"), certain discretionary provisions enabled under said Act, including extensions to existing contracts pursuant to N.J.S.A. 40A:11-15 (16) (the "LPCL"), were subsequently adopted by PVWC; and

WHEREAS, the PVWC seeks a non-compensatory time extension for the Project thereby setting a new expiration date of July 1, 2025; and

WHEREAS, the Chief Engineer has recommended that the said changes to the Project be approved and a copy of the memorandum dated October 16, 2024 recommending approval of the said changes to the Project is attached hereto and made a part hereof as **Exhibit A**; and

NOW, THEREFORE, BE IT RESOLVED, by Passaic Valley Water Commission, in the County of Passaic, New Jersey:

1. That PVWC hereby authorizes and awards a contract extension to the terms as set forth hereinabove; and
2. That appropriate officers of the Commission are hereby authorized and directed to execute this Contract extension as set forth hereinabove and implement the terms of this extended Contract in accordance with this Resolution and the submissions provided in connection herewith, and the Secretary of PVWC to attest to this Contract extension and such other officers, employees and officials of PVWC are hereby authorized to perform such acts and execute such documents as are necessary to implement the terms and intentions of this Resolution; and
3. That this matter shall be advertised as required by New Jersey law, in accordance with an appropriate form of notice, and a copy of this Resolution shall be placed on file and made available for public inspection at the office of the Administrative Secretary of Passaic Valley Water Commission.

RECORD OF COMMISSION VOTE ON FINAL PASSAGE

| | AYE | NAY | ABSTAIN | ABSENT |
|---------------------------|------------|------------|----------------|---------------|
| VAN RENSA LIER, R. | — | — | — | <u>X</u> |
| COTTON, R. | <u>X</u> | — | — | — |
| SANCHEZ, R. | <u>X</u> | — | — | — |
| KOŁODZIEJ, J. | <u>X</u> | — | — | — |
| DEPADUA, C. | <u>X</u> | — | — | — |
| FRIEND, G. | <u>X</u> | — | — | — |
| LEVINE, J. | <u>X</u> | — | — | — |

Adopted at a meeting of Passaic Valley Water Commission.

President
JEFFREY LEVINE

Secretary
RUBY N. COTTON

This Resolution, when adopted, must remain in the custody of the Administrative Secretary.

CERTIFICATION

I, LOUIS AMODIO, Administrative Secretary of the Passaic Valley Water Commission in the County of Passaic, and the State of New Jersey do hereby certify that the foregoing Resolution is a true copy thereof of the foregoing Resolution duly passed and adopted by a majority of a legal quorum of the full membership of the Passaic Valley Water Commission at its duly noticed and convened meeting of the said Commission on October 23, 2024.

LOUIS AMODIO
Administrative Secretary

EXHIBIT A

**PASSAIC VALLEY WATER COMMISSION
INTEROFFICE MEMORANDUM**

Date: October 16, 2024

To: J. Mueller

From: P. Porcaro

cc: C. Vozzella, J. Alesandrelli, L. Bresemann, Y. Weiss

Re: Resolution No. 24-126: Time Extension for Project 20-P-91 Entitled "Professional Services for FERC Regulatory-Required Improvements to PVWC's Intake Canal Facilities and Interfacing with Project 15-P-41"

Project No. 20-P-91 entitled "Professional Services for FERC Regulatory-Required Improvements to PVWC's Intake Canal Facilities and Interfacing with Project 15-P-41" was awarded to Ramboll Americas Engineering (Ramboll) of Princeton, New Jersey at PVWC's March 10, 2021, Commission Meeting (Resolution No. 21-33) not to exceed \$2,498,800.00.

We recommend a time extension to July 1, 2025, to complete all required site investigations and develop a Basis of Design Report for the rehabilitation of the PVWC's Intake Canal, Headgates and Screenhouse Facilities at the LFWTP.

RESOLUTION # 24-127

RESOLUTION OF PASSAIC VALLEY WATER COMMISSION

**RESOLUTION FOR A TIME EXTENSION FOR PROJECT NO. 17-P-70 ENTITLED
"PROFESSIONAL ENGINEERING SERVICES FOR PVWC RESIDUALS HANDLING
UPGRADE"**

DATE OF ADOPTION: OCTOBER 23, 2024

Introduced by Commissioner: **RIGO SANCHEZ**

Seconded by Commissioner: **JOSEPH KOLODZIEJ**

WHEREAS, Passaic Valley Water Commission ("PVWC") has solicited and awarded for professional services (or extraordinary unspecifiable services) Project No. 17-P-70 entitled "Professional Engineering Services for PVWC Residuals Handling Upgrade" (hereinafter the "Project") under Resolution 18-29 on May 30, 2018, to Mott MacDonald LLC ("Mott"), of Iselin, New Jersey, with said solicitation and procurement of responses (and evaluation of same) undertaken through a fair and open process, as defined in N.J.S.A. 19:44A-20.7 (hereinafter the "Fair and Open Process"); and

WHEREAS, Mott has, and continues to, provide professional services related to the Project consistently, reliably, efficiently, and effectively on an as-needed basis; and

WHEREAS, the PVWC has requested for the firm assist the Construction Management consultant, AECOM, as Design Engineer during construction; and

WHEREAS, the Design Engineer shall be responsible for assisting the Commission during the bidding process, reviewing all shop drawing submittals, responding to RFIs during construction, assisting with design modifications during construction as needed and assisting with commissioning new facility; and

WHEREAS, under the Local Public Contracts Law N.J.S.A. 40A:11-1 et seq. as amended April 17, 2000 (the "Act"), certain discretionary provisions enabled under said Act, including extensions to existing contracts pursuant to N.J.S.A. 40A:11-15 (16) (the "LPCL"), were subsequently adopted by PVWC; and

WHEREAS, the PVWC seeks a non-compensatory time extension for the Project thereby setting a new expiration date of September 1, 2027; and

WHEREAS, the Chief Engineer has recommended that the said changes to the Project be approved and a copy of the memorandum dated October 16, 2024 recommending approval of the said changes to the Project is attached hereto and made a part hereof as **Exhibit A**; and

NOW, THEREFORE, BE IT RESOLVED, by Passaic Valley Water Commission, in the County of Passaic, New Jersey:

1. That PVWC hereby authorizes and awards a contract extension to the terms as set forth hereinabove; and
2. That appropriate officers of the Commission are hereby authorized and directed to execute this Contract extension as set forth hereinabove and implement the terms of this extended Contract in accordance with this Resolution and the submissions provided in connection herewith, and the Secretary of PVWC to attest to this Contract extension and such other officers, employees and officials of PVWC are hereby authorized to perform such acts and execute such documents as are necessary to implement the terms and intentions of this Resolution; and
3. That this matter shall be advertised as required by New Jersey law, in accordance with an appropriate form of notice, and a copy of this Resolution shall be placed on file and made available for public inspection at the office of the Administrative Secretary of Passaic Valley Water Commission.

RECORD OF COMMISSION VOTE ON FINAL PASSAGE

| | AYE | NAY | ABSTAIN | ABSENT |
|---------------------------|--------------|------------|----------------|---------------|
| VAN RENSA LIER, R. | — | — | — | <u> X </u> |
| COTTON, R. | <u> X </u> | — | — | — |
| SANCHEZ, R. | <u> X </u> | — | — | — |
| KO LODZIEJ, J. | <u> X </u> | — | — | — |
| DE PADUA, C. | <u> X </u> | — | — | — |
| FRIEND, G. | <u> X </u> | — | — | — |
| LEVINE, J. | <u> X </u> | — | — | — |

Adopted at a meeting of Passaic Valley Water Commission.



President
JEFFREY LEVINE



Secretary
RUBY N. COTTON

This Resolution, when adopted, must remain in the custody of the Administrative Secretary.

CERTIFICATION

I, LOUIS AMODIO, Administrative Secretary of the Passaic Valley Water Commission in the County of Passaic, and the State of New Jersey do hereby certify that the foregoing Resolution is a true copy thereof of the foregoing Resolution duly passed and adopted by a majority of a legal quorum of the full membership of the Passaic Valley Water Commission at its duly noticed and convened meeting of the said Commission on October 23, 2024.

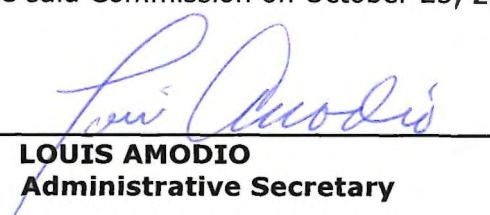

LOUIS AMODIO
Administrative Secretary

EXHIBIT A

**PASSAIC VALLEY WATER COMMISSION
INTEROFFICE MEMORANDUM**

Date: October 16, 2024

To: J. Mueller

From: P. Porcaro

cc: C. Vozzella, J. Alesandrelli, L. Bresemann, Y. Weiss

Re: Resolution No. 24-127: Time Extension for Project 17-P-70 Entitled "Professional Engineering Services for PVWC Residuals Handling Upgrade"

Project No. 17-P-70 Entitled "Professional Engineering Services for PVWC Residuals Handling Upgrade" was awarded to Mott MacDonald LLC (Mott), of Iselin, New Jersey at PVWC's May 30, 2018, Commission Meeting (Resolution No. 18-29) not to exceed \$2,579,097.00.

We recommend a time extension to September 1, 2027, for the firm to assist the Construction Management consultant as Design Engineer during construction. The Design Engineer shall be responsible for assisting the Commission during the bidding process, reviewing all shop drawing submittals, responding to RFIs during construction, assisting with design modifications during construction as needed and assisting with commissioning new facility.

RESOLUTION # 24-128

RESOLUTION OF PASSAIC VALLEY WATER COMMISSION

**RESOLUTION FOR A TIME EXTENSION FOR PROJECT NO. 16-P-64 ENTITLED
"PROFESSIONAL SERVICES FOR NEW STREET RESERVOIR WATER STORAGE AND
PUMPING FACILITIES DESIGN, PERMITTING AND CONSTRUCTION
ADMINISTRATION"**

DATE OF ADOPTION: OCTOBER 23, 2024

Introduced by Commissioner: **RIGO SANCHEZ**

Seconded by Commissioner: **JOSEPH KOLODZIEJ**

WHEREAS, Passaic Valley Water Commission ("PVWC") has solicited and awarded for professional services (or extraordinary unspecifiable services) Project No. 16-P-64 entitled "Professional Services for New Street Reservoir Water Storage and Pumping Facilities Design, Permitting and Construction Administration" (hereinafter the "Project") on July 20, 2016, to Arcadis U.S., Inc. ("Arcadis") of Fair Lawn, New Jersey, with said solicitation and procurement of responses (and evaluation of same) undertaken through a fair and open process, as defined in N.J.S.A. 19:44A-20.7 (hereinafter the "Fair and Open Process"); and

WHEREAS, Arcadis has, and continues to, provide professional services related to the Project consistently, reliably, efficiently, and effectively on an as-needed basis; and

WHEREAS, the PVWC has requested the firm to finalize the Commission's Reservoir Management Plan and conduct additional updates to the Hydraulic Modeling and System Summary Report that has been filed with the DOJ, EPA and NJDEP; and

WHEREAS, under the Local Public Contracts Law N.J.S.A. 40A:11-1 et seq. as amended April 17, 2000 (the "Act"), certain discretionary provisions enabled under said Act, including extensions to existing contracts pursuant to N.J.S.A. 40A:11-15 (16) (the "LPCL"), were subsequently adopted by PVWC; and

WHEREAS, the PVWC seeks a non-compensatory time extension for the Project thereby setting a new expiration date of August 1, 2025; and

WHEREAS, the Chief Engineer has recommended that the said changes to the Project be approved and a copy of the memorandum dated October 16, 2024 recommending approval of the said changes to the Project is attached hereto and made a part hereof as **Exhibit A**; and

NOW, THEREFORE, BE IT RESOLVED, by Passaic Valley Water Commission, in the County of Passaic, New Jersey:

1. That PVWC hereby authorizes and awards a contract extension to the terms as set forth hereinabove; and
2. That appropriate officers of the Commission are hereby authorized and directed to execute this Contract extension as set forth hereinabove and implement the terms of this extended Contract in accordance with this Resolution and the submissions provided in connection herewith, and the Secretary of PVWC to attest to this Contract extension and such other officers, employees and officials of PVWC are hereby authorized to perform such acts and execute such documents as are necessary to implement the terms and intentions of this Resolution; and
3. That this matter shall be advertised as required by New Jersey law, in accordance with an appropriate form of notice, and a copy of this Resolution shall be placed on file and made available for public inspection at the office of the Administrative Secretary of Passaic Valley Water Commission.

RECORD OF COMMISSION VOTE ON FINAL PASSAGE

| | AYE | NAY | ABSTAIN | ABSENT |
|---------------------------|--------------|------------|----------------|---------------|
| VAN RENSA LIER, R. | — | — | — | <u> X </u> |
| COTTON, R. | <u> X </u> | — | — | — |
| SANCHEZ, R. | <u> X </u> | — | — | — |
| KOŁODZIEJ, J. | <u> X </u> | — | — | — |
| DEPADUA, C. | <u> X </u> | — | — | — |
| FRIEND, G. | <u> X </u> | — | — | — |
| LEVINE, J. | <u> X </u> | — | — | — |

Adopted at a meeting of Passaic Valley Water Commission.



President
JEFFREY LEVINE

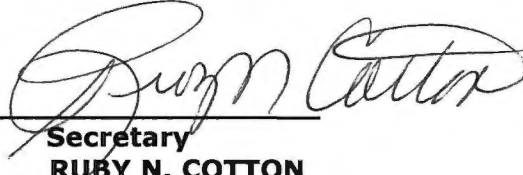

Secretary
RUBY N. COTTON

This Resolution, when adopted, must remain in the custody of the Administrative Secretary.

CERTIFICATION

I, LOUIS AMODIO, Administrative Secretary of the Passaic Valley Water Commission in the County of Passaic, and the State of New Jersey do hereby certify that the foregoing Resolution is a true copy thereof of the foregoing Resolution duly passed and adopted by a majority of a legal quorum of the full membership of the Passaic Valley Water Commission at its duly noticed and convened meeting of the said Commission on October 23, 2024.

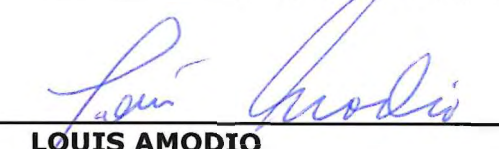

LOUIS AMODIO
Administrative Secretary

EXHIBIT A

**PASSAIC VALLEY WATER COMMISSION
INTEROFFICE MEMORANDUM**

Date: October 16, 2024

To: J. Mueller

From: P. Porcaro

cc: C. Vozzella, J. Alesandrelli, L. Bresemann, Y. Weiss

Re: Resolution No. 24-128: Time Extension for Project 16-P-64 Entitled "Professional Services for New Street Reservoir Water Storage and Pumping Facilities Design, Permitting and Construction Administration"

Project No. 16-P-64 entitled "Professional Services for New Street Reservoir Water Storage and Pumping Facilities Design, Permitting and Construction Administration" was awarded to Arcadis U.S., Inc. (Arcadis) of Fair Lawn, New Jersey at PVWC's July 20, 2016, Commission Meeting not to exceed \$2,109,620.00. Amendment No. 1 - 2 was approved by the Board revising the total not to exceed amount to \$2,423,350.00.

We recommend a time extension to August 1, 2025 for the firm to finalize the Commission's Reservoir Management Plan and conduct additional updates to the Hydraulic Modeling & System Summary Report that has been filed with the DOJ, EPA and NJDEP.

RESOLUTION # 24-129

RESOLUTION OF PASSAIC VALLEY WATER COMMISSION

RESOLUTION TO APPROVE CHANGE ORDER NO. 11 AND TIME EXTENSION FOR PROJECT NO. 12-P-43 ENTITLED "PROFESSIONAL ENGINEERING SERVICES FOR EMERGENCY BACKUP POWER AND LEVINE TANKS PROJECTS"

DATE OF ADOPTION: OCTOBER 23, 2024

Introduced by Commissioner: **RIGO SANCHEZ**

Seconded by Commissioner: **JOSEPH KOLODZIEJ**

WHEREAS, PVWC awarded Contract No. 12-P-43 entitled "Professional Engineering Services for Emergency Backup Power and Levine Tanks Projects" (the "Project") to CH2M Hill Engineers, Inc. ("CH2M") of Parsippany, New Jersey at PVWC's Commission Meeting on June 19, 2013 all in accordance with N.J.S.A. 40A:11-15; and in an amount not to exceed \$3,188,397.00; and

WHEREAS, Amendment 1 - 10 revised the total not-to-exceed price to \$7,285,306.50 for said Project; and

WHEREAS, CH2M has provided additional project management services for overseeing the work activities relating to the final completion of the Emergency Generator Project, Contract No. 15-B-25, performed by Stone Hill Contracting; and

WHEREAS, it is recommended that PVWC issues Change Order No. 11 to continue support for the duration of said contract and increase the Contract Price with an additional increase of \$86,400.00 which brings the total adjusted Contract Price up to \$7,371,706.50; and

WHEREAS, the Chief Engineer has reviewed CH2M's Proposal dated October 2, 2024 for ongoing work and work already performed, attached hereto and made a part hereof as **Exhibit A** and found it to be reasonable, considering the nature and scope of additional Work involved; and

WHEREAS, the PVWC seeks a non-compensatory time extension for the Project thereby setting a new expiration date of December 20, 2024; and

WHEREAS, it is recommended that the said changes to the Project, and additional costs related thereto, be approved, and a copy of the memorandum dated October 16, 2024 recommending approval of the said changes to the Project is attached hereto and made a part hereof as **Exhibit B**; and

WHEREAS, PVWC's Chief Financial Officer has certified, with respect hereto, that funds are currently available for said purpose and a copy of the said certification is attached hereto and made a part hereof as **Exhibit C**.

NOW, THEREFORE, BE IT RESOLVED, by Passaic Valley Water Commission, in the County of Passaic, New Jersey:

1. That PVWC hereby authorizes Change Order No. 11 and contract extension to the terms as set forth hereinabove; and
2. That appropriate officers of the Commission are hereby authorized and directed to execute this Contract extension as set forth hereinabove and implement the terms of this extended Contract in accordance with this Resolution and the submissions provided in connection herewith, and the Secretary of PVWC to attest to this Contract extension and such other officers, employees and officials of PVWC are hereby authorized to perform such acts and execute such documents as are necessary to implement the terms and intentions of this Resolution; and
3. That this matter shall be advertised as required by New Jersey law, in accordance with an appropriate form of notice, and a copy of this Resolution shall be placed on file and made available for public inspection at the office of the Administrative Secretary of Passaic Valley Water Commission.

RECORD OF COMMISSION VOTE ON FINAL PASSAGE

| | AYE | NAY | ABSTAIN | ABSENT |
|--------------------------|------------|------------|----------------|---------------|
| VAN RENSALIER, R. | — | — | — | <u>X</u> |
| COTTON, R. | <u>X</u> | — | — | — |
| SANCHEZ, R. | <u>X</u> | — | — | — |
| KOLODZIEJ, J. | <u>X</u> | — | — | — |
| DEPADUA, C. | <u>X</u> | — | — | — |
| FRIEND, G. | <u>X</u> | — | — | — |
| LEVINE, J. | <u>X</u> | — | — | — |

Adopted at a meeting of Passaic Valley Water Commission.



President
JEFFREY LEVINE



Secretary
RUBY N. COTTON

This Resolution, when adopted, must remain in the custody of the Administrative Secretary.

CERTIFICATION

I, LOUIS AMODIO, Administrative Secretary of the Passaic Valley Water Commission in the County of Passaic, and the State of New Jersey do hereby certify that the foregoing Resolution is a true copy thereof of the foregoing Resolution duly passed and adopted by a majority of a legal quorum of the full membership of the Passaic Valley Water Commission at its duly noticed and convened meeting of the said Commission on October 23, 2024.



LOUIS AMODIO
Administrative Secretary

EXHIBIT A



412 Mount Kemble Avenue
Suite 100S
P.O. Box. 1936
Morristown, NJ 07960-1936
(973) 267-0555 Voice
(973) 267-3555 Fax
www.jacobs.com

Julie Alesandrelli, P.E.
Passaic Valley Water Commission
1525 Main Avenue
Clifton, NJ 07011

October 2, 2024

Re: Project No. 12-P-43 - Professional Engineering Services Emergency Back-Up Power and Water Storage Facilities Design, Permitting and Construction Administrative Services Emergency Power – Funding Request for Engineering Services

Dear Ms. Alesandrelli:

PVWC awarded CH2M the Professional Engineering Services for the Emergency Back-Up Power and Water Storage Facilities Design, Permitting and Services During Construction on June 19, 2013. Per our original proposal, which was derived from the RFP, the construction period was to last 390 calendar days. The project is ongoing and several change orders have been processed during that time. The most recent was Change Order 10, authorized in May 2023. Change Order 10 provided funding for continued engagement of the design team and extension of construction administration, project management and resident engineering services through the anticipated project completion date of June 23, 2023. Following CO10, PVWC authorized additional funds in the amount of \$207,280 for ongoing services from Jacobs.

While substantial completion was achieved on July 14, 2023, construction efforts have continued for completion of various punch list items and new contract work authorized in Work Change Directive to Stone Hill Contracting (SHC) for connection of the power meters in the utility and plant switchgear to relay data into the plant SCADA system. PVWC extended SHCs construction contract to August 2, 2024 for the ongoing work.

Funds authorized by PVWC have supported Jacobs work efforts through June 14, 2024. However, work efforts have continued, and current efforts are ongoing for project closeout. It is expected that all project closeout efforts will be completed by Jacobs as of December 20, 2024. SHC has a maintenance agreement with PVWC that runs through August 1, 2025. This change order is requesting funding for Jacobs efforts from June 15, 2024 through December 20, 2024; a period of 27 weeks. Funding is requested for a total of 450 hours at a cost of \$86,400; providing for extension of construction administration, project management, limited resident engineering services, and continued engagement of the design team as needed.

In addition to the extended time period for services, the following unanticipated work efforts have been, or will be provided, by team members as identified:

- Completion of an asset survey for all assets associated with the emergency generator project. - Resident Engineer, PM, Senior Technologist for Asset Surveys, support engineer.
- Response to H2M inquiry on system features relating to the Discharge Prevention Containment and Countermeasure requirements – PM, mechanical engineer, DPCC specialist.

October 2, 2024

- Assistance to PVWC in negotiation of revised contract end date with SHC to August 2, 2024. And SHC provision of a one year maintenance contract through August 1, 2025. - Resident engineer and PM
- Jacobs worked with SHC to identify that operation of the generators on load banks could be executed to complete thermographic assessment of the new equipment. This work effort was completed in July 2024 and each of the four generators were operated on loads varying from 25 to 100% of their capacity. Thermographic testing was completed during the generator operation. - Resident engineer and PM.
- Extensive comments on and tracking of submittals and updates of various maintenance agreements required for the contract. - Resident engineer and PM
- Support of operation of the full plant load on generator power on September 24, 2024, requiring input from the electrical design engineer and Project Manager.
- Updates of the January 2023 Overall Operation and Maintenance Manual to address comments received from PVWC in September 2024 following operation of the generators on plant load. - PM, electrical design engineer, support staff.
- Loan extension beyond June 2024, requiring preparation and submittal of a final pay application. PM and resident engineer
- Coordination with SHC to identify a means for providing viewing of all Kohler screens in the plant SCADA, or an additional HMI screen – PM and resident engineer.
- Ongoing efforts to verify power meter data transmission following distribution of plant load to multiple transformers in September 2024. PM and resident engineer
- General project management and response to PVWC inquiries through project closeout planned for December 20, 2024. PM, resident engineer, electrical design engineer

We appreciate your consideration of providing a budget increase for our ongoing construction support services provided. Please let us know if you need any additional information.

Sincerely,



Russell Ford
Jacobs



Linda Wancho
Jacobs

C: Pat Porcaro, PVWC

EXHIBIT B

**PASSAIC VALLEY WATER COMMISSION
INTEROFFICE MEMORANDUM**

Date: October 16, 2024

To: J. Mueller

From: P. Porcaro

cc: C. Vozzella, J. Alesandrelli, L. Bresemann, Y. Weiss

Re: Resolution No. 24-129: Change Order No. 11 and Time Extension for Project 12-P-43 Entitled "Professional Engineering Services for Emergency Backup Power and Levine Tanks Projects"

Project No. 12-P-43 entitled "Professional Engineering Services for Emergency Backup Power and Levine Tanks Projects" was awarded to CH2M Hill Engineers, Inc. ("Professional") of Parsippany, New Jersey at PVWC's Commission Meeting dated June 19, 2013 (PVWC Resolution 13-76), and with reimbursement to be on a time-and-materials basis not to exceed \$3,188,397.00. CH2M Hill Engineers Inc., acquired by Jacobs Engineering Group Inc. ("Jacobs") in the latter half of 2017, was not dissolved and remains the Professional for this Contract. Therefore, the proposed change order, and the payment if approved, would be between the Commission and CH2M Hill Engineers Inc. Amendment 1 - 10 revised the not-to-exceed total price of \$7,285,306.50 for the Project.

The following unanticipated work efforts have been, or will be provided, by team members as identified:

1. Completion of an asset survey for all assets associated with the emergency generator project.
2. Response to H2M inquiry on system features relating to the Discharge Prevention Containment and Countermeasure requirements.
3. Assistance to PVWC in negotiation of revised contract end date with SHC to August 2, 2024. And SHC provision of a one year maintenance contract through August 1, 2025.
4. Jacobs worked with SHC to identify that operation of the generators on load banks could be executed to complete thermographic assessment of the new equipment. This work effort was completed in July 2024 and each of the four generators were operated on loads varying from 25 to 100% of their capacity. Thermographic testing was completed during the generator operation.
5. Extensive comments on and tracking of submittals and updates of various maintenance agreements required for the contract.
6. Support of operation of the full plant load on generator power on September 24, 2024, requiring input from the electrical design engineer and Project Manager.
7. Updates of the January 2023 Overall Operation and Maintenance Manual to address comments received from PVWC in September 2024 following operation of the generators on plant load.
8. Loan extension beyond June 2024, requiring preparation and submittal of a final pay application.
9. Coordination with SHC to identify a means for providing viewing of all Kohler screens in the plant SCADA, or an additional HMI screen.
10. Ongoing efforts to verify power meter data transmission following distribution of plant load to multiple transformers in September 2024.
11. General project management and response to PVWC inquiries through project closeout planned for December 20, 2024.

Proposed Change Order No. 11 increases the Contract Price by an additional \$86,400 which brings the total adjusted Contract Price to \$7,371,706.50 and a time extension to December 20, 2024.

EXHIBIT C

OFFICE OF THE COMPTROLLER

CERTIFICATION OF AVAILABILITY OF FUNDS

It is hereby certified that subject to Commission approval of future Budgets, with respect to multi-budget year contracts, there are or will be sufficient available funds for expenditures to be incurred as result of any contract or commitment to be entered into by Passaic Valley Water Commission as follows:

Description of Project or Contract: Project No. 12-P-43 – Change Order No. 11
“Professional Engineering Services for Emergency
Backup Power and Levine Tanks Projects”
Jacobs Engineering formerly CH2M Hill

Amount of Project or Contract:

Project No. 12-P-43
Increase of \$86,400.00
Not to Exceed \$7,371,706.50

1. Acct: # 001-0901-419-95-24
CAPITAL/Reservoir Covers
2. Specific Appropriation to which expenditures will be charged:
CAPITAL – 2024/2025

Other comments: Change Order Number 11 – Increase of \$86,400.00
for a New Not-to-Exceed of \$7,371,706.50

Date of Certification: October 17, 2024

Amount Certified: \$7,371,706.50

Yitzchak Weiss
Comptroller and Chief Financial Officer

YW:lb

RESOLUTION NO. 24-130

RESOLUTION OF PASSAIC VALLEY WATER COMMISSION

**RESOLUTION TO APPROVE CHANGE ORDER NO. 1 AND TIME EXTENSION FOR
CONTRACT NO. 22-B-08 ENTITLED "LEAD SERVICE LINE REPLACEMENT IN THE
MAIN SYSTEM"**

DATE OF ADOPTION: OCTOBER 23, 2024

Introduced by Commissioner: **RIGO SANCHEZ**

Second by Commissioner: **JOSEPH KOLODZIEJ**

WHEREAS, PVWC awarded Award Contract No. 22-B-08 entitled "Lead Service Line Replacement in the Main System" (the "Contract") to Pacific Construction, LLC ("Pacific") of Whitehouse Station, New Jersey at PVWC's Commission Meeting under Resolution No. 22-049 on May 11, 2022, not to exceed \$26,033,994.00; and

WHEREAS, Change Order No. 1 will cover modifications of work scope which include extra restoration work, abandonment of extra service lines to vacant lots, installation of additional traffic control measures, increase for police traffic directors, additional curb stop and service line replacement, additional meter relocation, additional customer coordination and managing electrical grounding issues, with a total increase of \$3,492,090.96 (13.4% increase) which brings the total adjusted Contract Price up to \$29,526,084.96; and

WHEREAS, the Commission's construction management firm, CDM Smith, has reviewed Pacific's Proposals for ongoing work and expenditures already performed by contractor and found it to be reasonable, considering the nature and scope of additional Work involved, and has recommended that the said changes to the Project, and additional costs related thereto, be approved, and a copy of the State of New Jersey Contract Modification Proposal and Acceptance Form No. CCS-002 describing all changes to the Contract is attached hereto and made a part hereof as **Exhibit A**; and

WHEREAS, the PVWC seeks a non-compensatory time extension for the Contract thereby setting a new expiration date of July 3, 2025; and

WHEREAS, it is recommended that the said changes to the Project, and additional costs related thereto, be approved, and a copy of the memorandum dated October 16, 2024 recommending approval of the said changes to the Project is attached hereto and made a part hereof as **Exhibit B**; and

WHEREAS, PVWC's Chief Financial Officer has certified, with respect hereto, that funds are currently available for said purpose and a copy of the said certification is attached hereto and made a part hereof as **Exhibit C**.

NOW, THEREFORE, BE IT RESOLVED, by Passaic Valley Water Commission, in the County of Passaic, New Jersey:

1. That PVWC hereby authorizes Change Order No. 1 and contract extension to the terms as set forth hereinabove; and
2. That appropriate officers of the Commission are hereby authorized and directed to execute this Contract extension as set forth hereinabove and implement the terms of this extended Contract in accordance with this Resolution and the submissions provided in connection herewith, and the Secretary of PVWC to attest to this Contract extension and such other officers, employees and officials of PVWC are hereby authorized to perform such acts and execute such documents as are necessary to implement the terms and intentions of this Resolution; and
3. That this matter shall be advertised as required by New Jersey law, in accordance with an appropriate form of notice, and a copy of this Resolution shall be placed on file and made available for inspection at the office of the Administrative Secretary of Passaic Valley Water Commission.

RECORD OF COMMISSION VOTE ON FINAL PASSAGE

| | AYE | NAY | ABSTAIN | ABSENT |
|---------------------------|-----------------|------------|----------------|-----------------|
| VAN RENSA LIER, R. | — | — | — | <u>X</u> |
| COTTON, R. | <u>X</u> | — | — | — |
| SANCHEZ, R. | <u>X</u> | — | — | — |
| KOLODZIEJ, J. | <u>X</u> | — | — | — |
| DEPADUA, C. | <u>X</u> | — | — | — |
| FRIEND, G. | <u>X</u> | — | — | — |
| LEVINE, J. | <u>X</u> | — | — | — |

Adopted at a meeting of Passaic Valley Water Commission.



President
JEFFREY LEVINE



Secretary
RUBY N. COTTON

This Resolution, when adopted, must remain in the custody of the Administrative Secretary.

CERTIFICATION

I, LOUIS AMODIO, Administrative Secretary of the Passaic Valley Water Commission in the County of Passaic, and the State of New Jersey do hereby certify that the foregoing Resolution is a true copy thereof of the foregoing Resolution duly passed and adopted by a majority of a legal quorum of the full membership of the Passaic Valley Water Commission at its duly noticed and convened meeting of the said Commission on October 23, 2024.



LOUIS AMODIO
Administrative Secretary

EXHIBIT A

CONTRACT MODIFICATION PROPOSAL AND ACCEPTANCE

| | | | |
|--|-------------------------------|--|---------------------------|
| 1. ISSUING OFFICE Passaic Valley Water Commission | 2. PROJECT NO. 1605002-002 | 3. CONTRACT NO. #22-B-8 | 4. MODIFICATION NO. 01 |
| 5. TO (CONTRACTOR) Pacific Construction, LLC. 532 Route 22 East, PMB 240 Whitehouse Station, NJ 08889 | | 6. PROJECT LOCATION AND DESCRIPTION Lead Service Line Replacement in The Main System | |

7. A proposal is required for making the hereinafter described change in accordance with specification and drawing revisions cited herein or listed in attachment hereto. Submit your proposal in space indicated on page 2, attach detailed breakdown of prime and sub-contract costs. (See the clause of this contract entitled, "Changes." DO NOT start work under this proposed change until you receive a copy signed by the Contracting Officer or a directive to proceed).

_____ Thomas R. Schoettle, P. E. Senior Vice President _____
 Date Type Name and Title Signature

8. DESCRIPTION OF CHANGE: Pursuant to the clause of this contract covering changes, the contractor shall furnish all labor and material, and all work necessary to accomplish the following described work:

See Attachment No. 1.

As a result of the above, the contract price is revised as follows:

| ITEM NO. | ITEM DESCRIPTION | UNIT PRICE | ESTIMATED QUANTITY | TOTAL COST |
|----------|------------------|------------|--------------------|------------|
|----------|------------------|------------|--------------------|------------|

See Attachment Nos. 2

TOTAL COST OF THIS MODIFICATION \$3,492,090.96

The contract time is hereby: increase decrease or remains the same by 97 calendar days as a result of this modification.

The foregoing modification is hereby accepted:

| | | | |
|-------------|-------------|-----------------------------------|----------|
| _____ | _____ | _____ | _____ |
| CONTRACTOR | OWNER | (NJPE SEAL) | ENGINEER |
| BY: _____ | BY: _____ | BY: <u>Thomas Schoettle, P.E.</u> | |
| DATE: _____ | DATE: _____ | DATE: _____ | |

APPROVAL:

_____ STATE OF NEW JERSEY _____ DATE

CONTRACT MODIFICATION PROPOSAL AND ACCEPTANCE

| | | | |
|---|--------------------------------|-----------------------------|----------------------------|
| 9. ISSUING OFFICE Passaic Valley Water Commission | 10. PROJECT NO. 1605002-002 | 11. CONTRACT NO. #22-B-8 | 12. MODIFICATION NO. 01 |
|---|--------------------------------|-----------------------------|----------------------------|

13. CONTRACTOR'S PROPOSAL – CHANGE IN CONTRACT PRICE
 (Detailed breakdown, attach additional sheets as necessary)

(Proposed)

See Attachment No 3

No costs have been declared unallowable by NJDEP. This change order is a combination of actual close and estimated cost to complete the project.

No cost have been associated with the change in contract time

| | | |
|--|--------------------------------|--|
| NET INCREASE \$ <u>3,492,090.96</u> | NET DECREASE \$ <u>0.00</u> | CALENDER DAYS INCREASE <u>97</u> DAYS |
|--|--------------------------------|--|

| | | |
|-------|--|------------|
| DATE: | TYPE NAME AND TITLE: Thomas R, Schoettle, P.E., Senior Vice President | SIGNATURE: |
|-------|--|------------|

CONTRACT MODIFICATION PROPOSAL AND ACCEPTANCE

| | | |
|---|--|----------------------------|
| 14. ISSUING OFFICE & PROJECT NO. Passaic Valley Water Commission 1605002-002 | 15. CONTRACT NO. #22-B-8 | 16. MODIFICATION NO. 01 |
| 17. ORIGINAL CONTRACT BID PRICE \$ <u>26,033,994.00</u> TOTAL OF PREVIOUS CHANGE ORDERS \$ <u>0.00</u> TOTAL CONTRACT COST INCLUDING CHANGE ORDERS..... \$ <u>29,526,084.96</u> | | |
| 18. NECESSITY FOR CHANGE AND REASON FOR OMISSION FROM PLANS AND SPECIFICATIONS: The change is necessitated to memorialize and document the addition of unit price pay items which exceed the contract quantity. The net adjustment in the Contract Price shall be in the amount of \$3,492,090.96 from the Total Contract Cost. | | |
| 19. OTHER IMPACTS RESULTANT OF THIS CHANGE: None. | | |
| 20. RESUME OF NEGOTIATIONS OR RECOMMENDATIONS (Loanee's Representative) : Refer to Attachment No.4. | | |
| DATE: | TYPE NAME AND TITLE OF LOANEE'S REPRESENTATIVE: Thomas R. Schoettle, P. E., Senior Vice President | SIGNATURE: |

**Passaic Valley Water Commission
Lead Service Line Replacement in the Main System
Contract #22-B-8**

**Change Order No. 01
Attachment No. 1
DESCRIPTION OF CHANGE**

- A. Original Contract Value of Contract #22-B-8 was \$26,033,994.00.
- B. The Contract Price has been increased by \$3,492,090.96 bringing the total Contract value to \$29,526,084.96. This adjustment is required to compensate the Contractor for additional unforeseen quantities in bid items required to complete the project.
- C. Increase the Contract Price by \$176,500.00 for Bid item 1A Abandonment of Service Line Replacement. The increase in price was necessitated by increasing the quantity by 706 due to exceeding the contract quantity.
- D. Increase the Contract Price by \$650.00 for Bid item 3 For Excavation and Removal of Concrete Road Base. The increase in price was necessitated by increasing the quantity by 6.5 CY due to exceeding the contract quantity.
- E. Increase the Contract Price by \$11,124.00 for Bid item 6 For Concrete Curb Restoration. The increase in price was necessitated by increasing the quantity by 927 LF due to exceeding the contract quantity and estimating quantity to completion.
- F. Increase the Contract Price by \$7,500.00 for Bid item 9 For Paver Block Restoration. The increase in price was necessitated by increasing the quantity by 50 SY due to exceeding the contract quantity and estimating quantity to completion.
- G. Increase the Contract Price by \$172,276.20 for Bid item 13A For 1" Diameter Copper Curb to Building. The increase in price was necessitated by increasing the quantity by 7845 LF due to exceeding the contract quantity and estimating quantity to completion.
- H. Increase the Contract Price by \$833,000.00 for Bid item 14A For 3/4" Curb Stops. The increase in price was necessitated by increasing the quantity by 490 due to exceeding the contract quantity and estimating quantity to completion and estimating quantity to completion.
- I. Increase the Contract Price by \$269,100.00 for Bid item 16 For Customer Coordination. The increase in price was necessitated by increasing the quantity by 299 due to exceeding the contract quantity and estimating quantity to completion.
- J. Increase the Contract Price by \$483,300.00 for Bid item 17 For Meter Relocation. The increase in price was necessitated by increasing the quantity by 537 due to exceeding the contract quantity and estimating quantity to completion.
- K. Increase the Contract Price by \$345,240.76 for Bid item 19 Allowance for Police Traffic Directors. The increase in price was necessitated by increasing the quantity by 19% due to exceeding the contract quantity and estimating quantity to completion.
- L. Increase the Contract Price by \$1,193,400.00 for Bid item 22 Allowance for Additional Work and Permit Fees. The increase in price was necessitated by increasing the quantity by 54% due to exceeding the contract quantity and estimating quantity to completion. Please see attached spreadsheet for breakdown of costs.
- M. The Contract Time has been increased by 97 calendar days bringing the final completion date from March 28, 2025 to July 3, 2025. The adjustment is required due to unforeseen additional items to complete the project.

**Passaic Valley Water Commission
Lead Service Line Replacement in the Main System
Contract #22-B-8**

Change Order No. 01

Attachment No. 2

| Calculations | | |
|---------------------|--|---|
| 1 | Original Contract Price | \$ 26,033,994.00 |
| 2 | Change Order No. 1 | \$3,492,090.96 |
| 3 | New Contract Value (line 1 + line 2) | \$ 29,526,084.96 |
| 4 | Total Adjustments from Contract Value Total Quantity Adjustments = - \$3,492,090.96 (See Attachment 3) Total Modification to the Contract = \$0.00 (See Attachment 4) | \$ - |
| 5 | Total Paid (Payment Applications 1 through 10) Payment Application No. 1 Payment Application No. 2 Payment Application No. 3 Payment Application No. 4 Payment Application No. 5 Payment Application No. 6 Payment Application No. 7 Payment Application No. 8 Payment Application No. 9 Payment Application No. 10 | \$ 16,223,845.83 \$ 587,763.51 \$ 726,791.40 \$ 1,895,012.73 \$ 189,456.10 \$ 1,566,056.83 \$ 1,281,821.45 \$ 1,739,468.84 \$ 2,935,369.13 \$ 1,654,167.93 \$ 3,647,937.91 |
| 6 | Total Payment Due (line 3 + line 4 - line 5) | \$ 13,302,239.13 |
| 7 | Total Amount Earned (line 5 + line 6) (See Attachment 3) | \$ 29,526,084.96 |
| 8 | Total Modification to the Contract (See Attachment 4) | \$ - |
| 9 | Amount Earned Adjusted for Modifications to the Contract (line 7 - line 8) | \$ 29,526,084.96 |
| 10 | Cross-Check - Amount of Payment (should equal line 6) (line 9 - line 4) | \$ 13,302,239.13 |

**Passaic Valley Water Commission
Phase X (A) Lead Service Line Replacement in the Main System
Contract #22-B-8**

Change Order No. 01

Attachment No. 4

MODIFICATION TO THE CONTRACT DOCUMENTS

None for this Contract.

| <u>Item</u> | <u>Description</u> | <u>Amount</u> |
|-------------|--|-----------------------|
| 1A | Abandonment of Service Line Replacement, at the unit price of: A. Excavation, Compaction and Backfill | \$176,500.00 |
| 3 | For Excavation and Removal of Concrete Road Base, at the unit price of: | \$650.00 |
| 6 | For Concrete Curb Restoration, at the unit price of | \$11,124.00 |
| 9 | For Paver Block Restoration, at the unit price of: | \$7,500.00 |
| 13A | 1" Diameter Copper Curb to Building | \$172,276.20 |
| 14A | 3/4" Curb Stops | \$833,000.00 |
| 16 | For Customer Coordination, at the unit price of: | \$269,100.00 |
| 17 | For Meter Relocation | \$483,300.00 |
| 19 | Allowance for Police Traffic Directors | \$345,240.76 |
| 22 | Allowance for Additional Work and Permit Fees | \$1,193,400.00 |
| | TOTAL COST OF WORK | \$3,492,090.96 |

EXHIBIT B

**PASSAIC VALLEY WATER COMMISSION
INTEROFFICE MEMORANDUM**

Date: October 16, 2024
To: J. Mueller
From: P. Porcaro
cc: C. Vozzella, A. Wells, L. Bresemann, Y. Weiss
Re: Resolution No. 24-130: Change Order No. 1 and Time Extension for Contract No. 22-B-08 Entitled "Lead Service Line Replacement in the Main System"

Project No. 22-B-08 entitled "Lead Service Line Replacement in the Main System" was awarded to Pacific Construction, LLC (Pacific) of Whitehouse Station, New Jersey at PVWC's May 11, 2022 Commission Meeting in the amount of \$26,033,994.00 with a substantial completion date of March 28, 2025.

Change Order No. 1 will cover various out of scope items which has been described in greater detail in the State of New Jersey Contract Modification Proposal and Acceptance Form No. CCS-002. Modification of work scope shall include extra restoration work, abandonment of extra service lines to vacant lots, installation of additional traffic control measures, increase for police traffic directors, additional curb stop and service line replacement, additional meter relocation, additional customer coordination and managing electrical grounding issues.

A time extension is needed to complete restoration work and to gain permission from unresponsive customers to replace the remaining lead service lines before final contract closeout.

Proposed Change Order No. 1 increases the Contract Price by an additional \$3,492,090.96 which brings the total adjusted Contract Price to \$29,526,084.96 and a time extension to July 3, 2025.

EXHIBIT C

OFFICE OF THE COMPTROLLER

CERTIFICATION OF AVAILABILITY OF FUNDS

It is hereby certified that subject to Commission approval of future Budgets, with respect to multi-budget year contracts, there are or will be sufficient available funds for expenditures to be incurred as result of any contract or commitment to be entered into by Passaic Valley Water Commission as follows:

Description of Project or Contract: Contract No. 22-B-08 – Change Order No. 1
“Lead Service Line Replacement in the Main System”
Pacific Construction, LLC

Amount of Project or Contract:

Contract No. 22-B-08
Increase of \$3,492,090.96
Not to Exceed \$29,526,084.96

1. Acct: # 001-0901-419-95-46
CAPITAL/Lead Service Replacements
2. Specific Appropriation to which expenditures will be charged:
CAPITAL – 2024/2025

Other comments: Change Order Number 1 – Increase of \$3,492,090.96
for a New Not-to-Exceed of \$29,526,084.96

Date of Certification: October 17, 2024

Amount Certified: \$29,526,084.96

Yitzchak Weiss
Comptroller and Chief Financial Officer

YW:lb

RESOLUTION NO. 24-131

PASSAIC VALLEY WATER COMMISSION

**RESOLUTION TO PROCURE ONE (1)
BERRYMAN CENTRIFUGAL BLOWER UNIT, MODEL BEC10-08**

DATE OF ADOPTION: OCTOBER 23, 2024

Introduced by Commissioner: **RIGO SANCHEZ**

Seconded by Commissioner: **JOSEPH KOLODZIEJ**

WHEREAS, the Commission needs to procure one (1) Berryman Centrifugal Blower Unit, Model BEC10-08 to be used at the LFWTP. This Blower is crucial to Plant operations. The current blower is beyond its useful life; and

WHEREAS, the North Jersey Wastewater Purchasing Cooperative, Contract B414-6, (the "Co-op") shall be used for the procurement of said blower; and

WHEREAS, in accordance with N.J.S.A. 40A:11-12, PVWC may purchase goods or services under contracts entered into on behalf of the State by the Division of Purchase and Property in the Department of the Treasury; and

WHEREAS, PVWC has elected to procure the above-referenced blower from Precision Electric Motor Works in Clifton, New Jersey (the "Awardee") under the "Co-op", in the amount of \$53,142.00 a copy of the quotation for the trucks is attached hereto as **Exhibit A**; and

WHEREAS, N.J.S.A. 40A:11-12 of the Local Public Contracts Law provides for the awarding of said contract to the Awardee; and

WHEREAS, PVWC's Chief Financial Officer has certified, with respect hereto, that funds are currently available for said purpose and a copy of the said certification is attached hereto and made a part hereof as **Exhibit B**.

NOW, THEREFORE, BE IT RESOLVED, by Passaic Valley Water Commission, in the County of Passaic, New Jersey;

1. That the Cooperative Pricing Agreement for procurement of the above-referenced blower is hereby awarded to the Awardee as set forth hereinabove; and
2. That the appropriate officers and employees of PVWC are hereby authorized and directed to perform such acts and execute such documents as are consistent herewith, with respect to the Cooperative Pricing Agreement as set forth hereinabove.

RECORD OF COMMISSION VOTE ON FINAL PASSAGE

| | AYE | NAY | ABSTAIN | ABSENT |
|--------------------------|---------------------|---------------|----------------|---------------------|
| VAN RENSALIER, R. | <u> </u> | <u> </u> | <u> </u> | <u> X </u> |
| COTTON, R. | <u> X </u> | <u> </u> | <u> </u> | <u> </u> |
| SANCHEZ, R. | <u> X </u> | <u> </u> | <u> </u> | <u> </u> |
| KOLODZIEJ, J. | <u> X </u> | <u> </u> | <u> </u> | <u> </u> |
| DEPADUA, C. | <u> X </u> | <u> </u> | <u> </u> | <u> </u> |
| FRIEND, G. | <u> X </u> | <u> </u> | <u> </u> | <u> </u> |
| LEVINE, J. | <u> X </u> | <u> </u> | <u> </u> | <u> </u> |

Adopted at a meeting of Passaic Valley Water Commission.

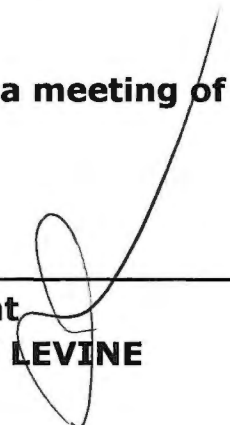

President
JEFFREY LEVINE



Secretary
RUBY N. COTTON

This Resolution, when adopted, must remain in the custody of the Administrative Secretary.

CERTIFICATION

I, LOUIS AMODIO, Administrative Secretary of the Passaic Valley Water Commission in the County of Passaic, and the State of New Jersey do hereby certify that the foregoing Resolution is a true copy thereof of the foregoing Resolution duly passed and adopted by a majority of a legal quorum of the full membership of the Passaic Valley Water Commission at its duly noticed and convened meeting of the said Commission on October 23, 2024.

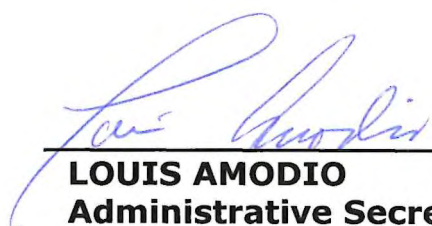

LOUIS AMODIO
Administrative Secretary

EXHIBIT A

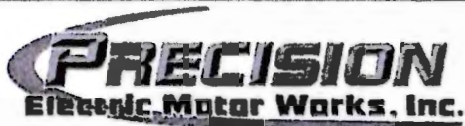

Quote

AN **IPS** COMPANY

18 SEBAGO ST., CLIFTON, NJ 07013
 TEL: (973) 471-2600 FAX: (973) 471-4633

Contact

Mike Marotta

Customer Number

PASSAIC WATER C

Quote Date

9/23/2024

Quote Number

SQ24154

Quote To:

Passaic Valley Water Commission
 1525 Main Avenue
 P.O. Box 230
 Clifton, NJ 07011

Ship To:

Passaic Valley Water Commission
 1525 Main Avenue
 P.O. Box 230
 Clifton, NJ 07011

FOB

Ship Via

Best Way

Terms

Net 30

Quoted By

Marty Matlessich

Customer RFQ

Customer PO

| Product ID | Qty | Description | Sales Price | Total |
|------------|-----|--|-------------|-----------|
| BEC10-08 | 1 | Berryman Centrifugal Blower Unit - Model BEC10-08 | 53,142.00 | 53,142.00 |
| | | BERRYMAN CENTRIFUGAL BLOWER UNIT MODEL - BEC10-08 REPLACES THE HOFFMAN MODEL 74208E1 AS SHOWN ON THE HOFFMAN DRAWING 300RMM815 | | |

Sales Tax and Freight are not included in total, unless noted otherwise. Quote is valid for <15> Days.

CO-OP CONTRACT B414-6

| | |
|-----------------------|------------------|
| Subtotal: | 53,142.00 |
| Freight: | 0.00 |
| Other: | 0.00 |
| 0.0000 % Sales Tax 1: | 0.00 |
| 0.0000 % Sales Tax 2: | 0.00 |
| Total: | 53,142.00 |

Thank You

SIGNATURE: _____ DATE: _____

PO# (IF NOT ALREADY ISSUED):

Inlet and Outlet Orientation Options

The orientation of the inlet and outlet is selectable from different positions, as shown below:

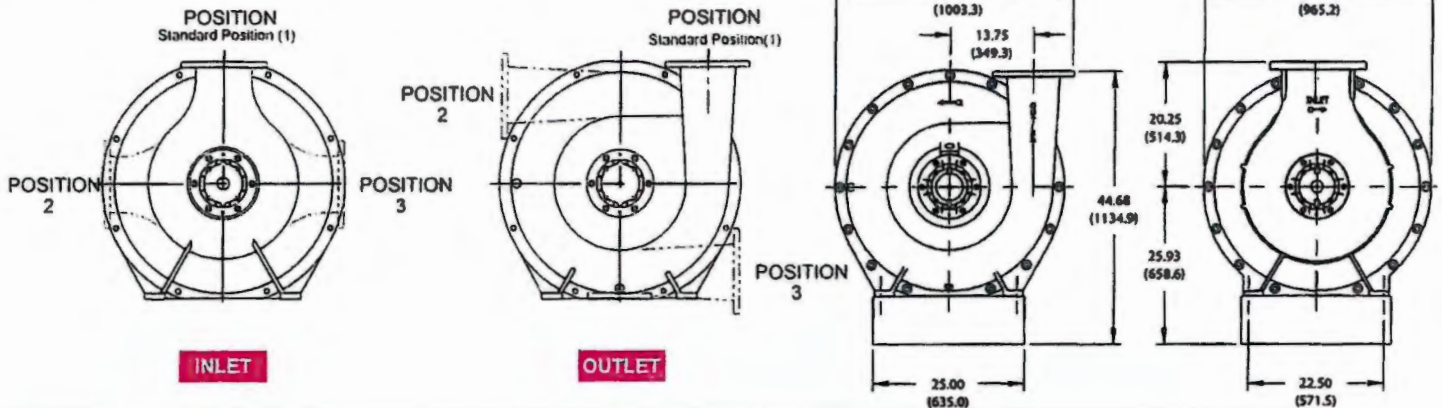

Dimensions

| Model | A | B | F [†] | L [†] |
|----------|--------------|--------------|----------------|----------------|
| BEC10-01 | 8.25 (210) | 13.25 (337) | 49 (1245) | 73 (1854) |
| BEC10-02 | 12.56 (319) | 17.56 (446) | 49 (1245) | 73 (1854) |
| BEC10-03 | 16.88 (429) | 21.88 (556) | 62 (1575) | 86 (2184) |
| BEC10-04 | 21.19 (538) | 26.18 (665) | 62 (1575) | 86 (2184) |
| BEC10-05 | 25.50 (648) | 30.50 (775) | 62 (1575) | 86 (2184) |
| BEC10-06 | 29.81 (757) | 34.81 (884) | 76 (1930) | 100 (2540) |
| BEC10-07 | 34.12 (867) | 39.13 (994) | 89 (2261) | 113 (2870) |
| BEC10-08 | 38.44 (976) | 43.44 (1103) | 89 (2261) | 113 (2870) |
| BEC10-09 | 42.75 (1086) | 47.75 (1213) | 89 (2261) | 113 (2870) |
| BEC10-10 | 47.06 (1195) | 52.06 (1322) | 106 (2692) | 130 (3302) |
| BEC10-11 | 51.38 (1305) | 56.38 (1432) | 106 (2692) | 130 (3302) |

Dimensions provided are approximate. Do not use for construction purposes.
 Dimension vary based on motor frame size.

Weight

| Model | Weight* | | Wk ² | |
|----------|---------|-------|--------------------|-------------------|
| | lb | kg | lb-ft ² | kg-m ² |
| BEC10-01 | 1,400 | 635 | 11 | 0.48 |
| BEC10-02 | 1,800 | 816 | 23 | 0.96 |
| BEC10-03 | 2,140 | 971 | 34 | 1.44 |
| BEC10-04 | 2,530 | 1,148 | 45 | 1.92 |
| BEC10-05 | 2,990 | 1,356 | 57 | 2.40 |
| BEC10-06 | 3,350 | 1,520 | 68 | 2.88 |
| BEC10-07 | 3,710 | 1,683 | 79 | 3.36 |
| BEC10-08 | 4,140 | 1,878 | 91 | 3.84 |
| BEC10-09 | 4,550 | 2,064 | 102 | 4.32 |
| BEC10-10 | 5,000 | 2,268 | 113 | 4.80 |
| BEC10-11 | 6,060 | 2,749 | 125 | 5.28 |

Note: Approximate weight of blower

General Arrangement

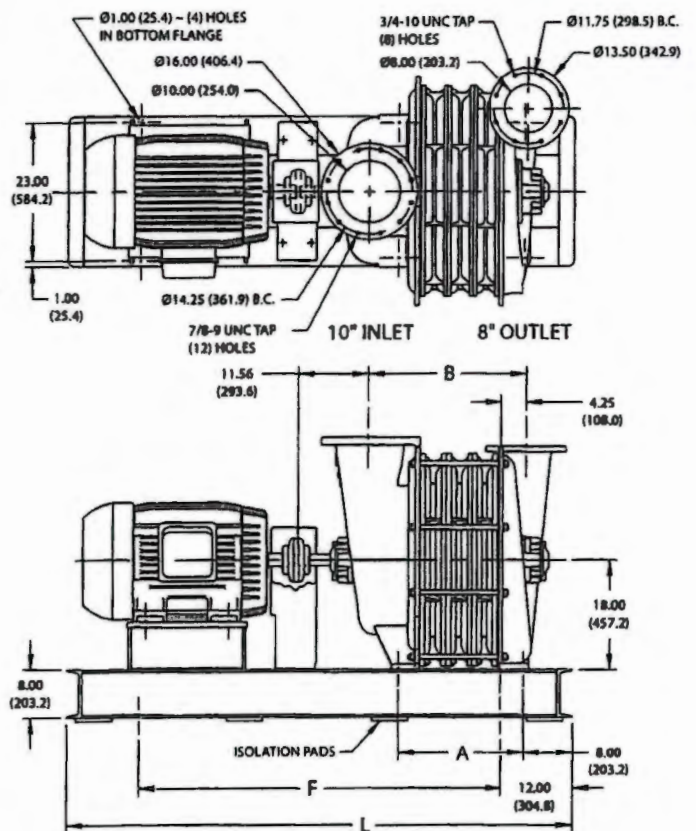

EXHIBIT B

RESOLUTION NO. 24-132

PASSAIC VALLEY WATER COMMISSION

**RESOLUTION TO PROCURE CAPACITATORS FOR A
WEDECO PDO OZONE GENERATOR**

DATE OF ADOPTION: OCTOBER 23, 2024

Introduced by Commissioner: **RIGO SANCHEZ**

Seconded by Commissioner: **JOSEPH KOLODZIEJ**

WHEREAS, the Passaic Valley Water Commission ("PVWC") wishes to procure Capacitators to replace the existing Capacitators for our current WEDECO PDO Ozone Generator System that is approaching the end of its expected service life, under the proprietary goods exception to the Local Public Contracts Law ("LPCL"); and

WHEREAS, WEDECO of Charlotte, North Carolina ("WEDECO") has provided PVWC with Quotation #2024-WED-1136, in the total amount of \$53,626.28; and

WHEREAS, WEDECO is the sole provider of the WEDECO PDO Ozone Generator System and its parts, which is utilized as the primary disinfection to water treatment; and

WHEREAS, the LPCL normally requires Contracting Units to give bidders the option to supply "equivalent" equipment to the brand name specified as per N.J.S.A. § 40A:11-13(d), N.J.A.C. § 5:34-9.2; and

WHEREAS, the LPCL allows Contracting Units, in appropriate situations, to designate certain brands of goods as "proprietary" when those brands of goods are "necessary for the conduct of [the Contracting Unit's] affairs" (hereinafter "the Proprietary Goods Exception") see N.J.S.A. § 40A:11-2(39), N.J.A.C. § 5:34-9.1 (a)(2)); and

WHEREAS, the Proprietary Goods Exception provides that if the Contracting Unit needs to procure goods "of a specialized nature" by one manufacturer, and the need for a certain brand is greater (or more valuable) than the "public benefit of permitting "brand name or equivalent" and the

benefits of...competition”, the Contracting Unit may processed with a bid specification that restricts bidders to supplying just that brand name of goods, to the exclusion of others; and

WHEREAS, a Contracting Unit may be entitled to opt for the Proprietary Goods Exception: (i) The contracting unit has a substantial investment in facilities, training, replacement parts, or complimentary items that warrants reliance on a specific manufacturer or vendor to maintain the value of the investment, and/or (ii) Unique circumstances as to a facility or environment preclude the use of other goods or services; and

WHEREAS, in accordance with the pre-requisite procedures for entitlement to use the Proprietary Goods Exception, the PVWC’s Buyer, Lisa Bresemann, prepared a Certification addressed to the Executive Director, General Counsel, and Chief Financial Officer to demonstrate entitlement to use the Proprietary Goods Exception, which is attached hereto as **Exhibit A**, the contents of which are deemed incorporated into this Resolution as set forth herein; and

WHEREAS, the Executive Director, General Counsel, and Chief Financial Officer reviewed the Certification and concur with the findings of the Buyer and ask the Commissioners to authorize the PVWC to designate the parts for the WEDECO PDO Ozone Generator such as Capacitators, as proprietary goods henceforth; and

WHEREAS, PVWC’s Chief Financial Officer has certified, with respect hereto, that funds are currently available for said purpose and a copy of the said certification is attached hereto and made a part hereof as **Exhibit B**.

WHEREAS, WEDECO’s quotation and other relevant correspondences are attached hereto and made a part hereof as **Exhibit C**; and

WHEREAS, the Commissioners, having received the aforementioned Certifications and recommendation, approve the above-referenced measures; and

NOW, THEREFORE, BE IT RESOLVED, by Passaic Valley Water Commission, in the County of Passaic, New Jersey;

1. That the Commissioners, in accordance with recommendations referenced above, hereby authorize the PVWC to procure the Capacitor equipment under the Proprietary Goods Exception to the Local Public Contracts Law; and
2. That the appropriate officers and employees of PVWC are hereby authorized and directed to perform such acts and execute such documents as are consistent herewith, with respect to the Cooperative Pricing Agreement as set forth hereinabove.

RECORD OF COMMISSION VOTE ON FINAL PASSAGE

| | AYE | NAY | ABSTAIN | ABSENT |
|--------------------------|-----------------|------------|----------------|-----------------|
| VAN RENSALIER, R. | ___ | ___ | ___ | <u>X</u> |
| COTTON, R. | <u>X</u> | ___ | ___ | ___ |
| SANCHEZ, R. | <u>X</u> | ___ | ___ | ___ |
| KOLODZIEJ, J. | <u>X</u> | ___ | ___ | ___ |
| DEPADUA, C. | <u>X</u> | ___ | ___ | ___ |
| FRIEND, G. | <u>X</u> | ___ | ___ | ___ |
| LEVINE, J. | <u>X</u> | ___ | ___ | ___ |

Adopted at a meeting of Passaic Valley Water Commission.



President
JEFFREY LEVINE



Secretary
RUBY N. COTTON

This Resolution, when adopted, must remain in the custody of the Administrative Secretary.

CERTIFICATION

I, LOUIS AMODIO, Administrative Secretary of the Passaic Valley Water Commission in the County of Passaic, and the State of New Jersey do hereby certify that the foregoing Resolution is a true copy thereof of the foregoing Resolution duly passed and adopted by a majority of a legal quorum of the full membership of the Passaic Valley Water Commission at its duly noticed and convened meeting of the said Commission on October 23, 2024.

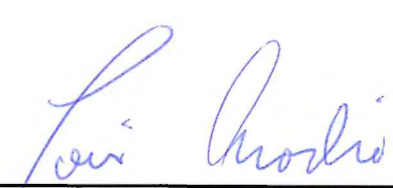

LOUIS AMODIO
Administrative Secretary

EXHIBIT A



PASSAIC VALLEY WATER COMMISSION
1525 MAIN AVENUE • P.O. BOX 230
CLIFTON, NEW JERSEY 07011 • (973) 340-4300
CLIFTON FAX # (973) 340-4321

COMMISSIONERS

Jeffrey Levine, President, Paterson
Rigoberto Sanchez, Vice President, Passaic
Joseph Kolodziej, Treasurer, Clifton
Ruby N. Cotton, Secretary, Paterson
Carmen DePadua, Commissioner, Paterson
Gerald Friend, Commissioner, Clifton
Ronald Van Rensalier, Commissioner, Passaic

Executive Director
James Mueller

Certification of PVWC Buyer, Lisa Bresemann, QPA pursuant to N.J.A.C. § 5:34-9.1

To: **James Mueller**, Executive Director
Yaacov M. Brisman, General Counsel
Yitzchak Weiss, Chief Financial Officer

RE: **Procurement of WEDECO Capacitators for WEDECO PDO Ozone Generator System**

1. I, Lisa Bresemann, QPA, am the Buyer for the Passaic Valley Water Commission ("PVWC"). My responsibilities are similar to those of "purchasing agents" in other public entities.
2. I make this Certification pursuant to N.J.A.C. § 5:34-9.1 in support of PVWC's position that PVWC is entitled to procure replacement parts from the Original Equipment Manufacturer (OEM), WEDECO, a Xylem Brand (WEDECO) for repairs at the Little Falls Water Treatment Plant as proprietary goods as that term is defined by N.J.S.A. § 40A:11-2(39).
3. Currently, PVWC procures replacement parts for this equipment from WEDECO without regard to brand, or by allowing "or equal" as per N.J.S.A. § 40A:11-13(d) of the Local Public Contracts Law.
4. WEDECO has provided a letter dated October 18, 2024, and is on file in the PVWC Buyer's office, verifying that Precision is the sole provider of the Continental motor which has been extensively damaged.
5. The PVWC Buyer recommends that the Board of Commissioners approve a Resolution authorizing the PVWC to have the Continental Motor repaired by Precision as a proprietary good.

I certify that the foregoing statements made by me are true to the best of my information, knowledge, and belief. I understand that if any of my statements are willfully false, that I may be subject to punishment.

Dated: October 18, 2024

Lisa Bresemann, Buyer
Passaic Valley Water Commission

EXHIBIT B

OFFICE OF THE COMPTROLLER

CERTIFICATION OF AVAILABILITY OF FUNDS

It is hereby certified that subject to Commission approval of future Budgets, with respect to multi-budget year contracts, there are or will be sufficient available funds for expenditures to be incurred as result of any contract or commitment to be entered into by Passaic Valley Water Commission as follows:

Description of Project or Contract: WEDECO, A Xylem Brand
Proprietary Purchase

Amount of Project or Contract: \$53,626.28

1. Acct: #- 001-0901-419-95-36
CAPITAL/Pumps
2. Specific Appropriation to which expenditures will be charged:
Capital Budget 2024/2025

Other comments: Single Purchase – Proprietary
WEDECO Capacitators

Date of Certification: October 16, 2024 Certified: \$53,626.28

Yitzchak Weiss
Comptroller and Chief Financial Officer

YW:lb

EXHIBIT C

September 13, 2024

653, 626. 28

Passaic Valley Water Commission
Little Falls WTP
Attn of: Mr. Mike Marotta
800 Union Avenue
Totowa, New Jersey 07512

Subject: WEDECO Ozone System Component Service Life - Capacitors

Dear Mr. Marotta:

Our records indicate that the WEDECO PDO Ozone Generator Systems at your facility have reached an age where, if not approaching end of expected service life, some components such as capacitors are highly recommended for replacement. Capacitors are critical engineered components that are specifically fit for ozone systems, and are expected to require replacement after approximately 15 years. Replacement capacitors can have a long lead time, so it is advisable to consider obtaining replacements for installation in your system. Please contact me or a member of my team to discuss options, or to obtain parts' pricing and availability.

With your facility's ozone system in operation for more than 10 years, it also may be time to plan for upgrading control components with new and supported modern processor hardware. We are committed to assisting our customers with options to provide long, reliable service life.

Xylem will continue to provide expert technical support and field service, as well as available consumables and spares, while supplies last.

Thank you for your consideration and for your continued business.

Best regards,

Richard Nash

Rick Nash
Aftermarket Territory Manager - Treatment
M: 980-259-4461 / Richard.Nash@xylem.com

cc: Xylem Treatment Aftermarket & Service – Charlotte, NC



**Xylem Water Solutions USA, Inc.
Wedeco Products**

September 13, 2024

4828 Parkway Plaza Blvd.
Suite 200
Charlotte, NC 28217
Tel 704/409-9700
Fax 704/409-9839

PASSAIC VALLEY WATER COMM
1525 MAIN AVE
PO BOX 230
CLIFTON NJ 07011-2170

Quote # 2024-WED-1136
Account #: 030597

Project Name: PASSAIC VALLEY WATER COMMISSION -
030597
Job Name: PDO9000 SPARE PARTS

Xylem Water Solutions USA, Inc. - WEDECO is pleased to provide a quote for the following equipment and/or services for your approval.

OZONE SPARES

| Qty | Part Number | Description | Unit Price | Extended Price |
|---------------------------|----------------|---|-------------|---------------------|
| 1 | 76-603 80 73 | DICON VERSION 09/2003 PCI2100-100 | \$ 3,675.00 | \$ 3,675.00 |
| 1 | 76-603 80 75 | HV BOARD PCI2100-125 | \$ 347.00 | \$ 347.00 |
| 1 | 76-603 80 76 | 4 SCR PULSE BOARD REV. 0 REPLACMT FOR 2021 BOARD | \$ 1,126.00 | \$ 1,126.00 |
| 1 | 14-65 29 70 | SCR RECITIFIER,2500V 760A AVG [HT750-1050] | \$ 221.00 | \$ 221.00 |
| 1 | 14-65 20 32 | DIODE MODULE 1600 VOLT [REPLAC | \$ 372.00 | \$ 372.00 |
| 9 | WB1349 | CAPACITOR 4 x 56.25 uF, 2.0 KVDC, REVA | \$ 3,424.62 | \$ 30,821.58 |
| 3 | 14-65 86 94 | OZONE DESTRUCT CATALYST CARULITE 200 4X8 MESH (44.1#) | \$ 2,427.00 | \$ 7,281.00 |
| 3 | 14-65 85 55 | PARATHERM HEAT TRANSFER FLUID 5 GAL PAIL - NON TOXIC | \$ 983.00 | \$ 2,949.00 |
| 6 | AF205-30-11-13 | MAIN CONTACTOR CTR, 3P, 192A, 100-250VAC/DC, 1/1 | \$ 1,138.95 | \$ 6,833.70 |
| OZONE SPARES Price | | | | \$ 53,626.28 |
| Total Price | | | | \$ 53,626.28 |

Terms & Conditions

This order is subject to the Standard Terms and Conditions of Sale – Xylem Americas effective on the date the order is accepted which terms are available at <http://www.xylem.com/en-us/Pages/terms-conditions-of-sale.aspx> and incorporated herein by reference and made a part of the agreement between the parties.

Freight Terms: 3 DAP - Delivered At Place 08 - Jobsite (per IncoTerms 2020)
See Terms of Delivery below for freight payment terms.

WEDECO
a xylem brand

Taxes: State, local and other applicable taxes are not included in this quotation.
Back Charges: Buyer shall not make purchases nor shall Buyer incur any labor that would result in a back charge to Seller without prior written consent of an authorized employee of Seller.
Shortages: Xylem will not be responsible for apparent shipment shortages or damages incurred in shipment that are not reported within two weeks from delivery to the jobsite. Damages should be noted on the receiving slip and the truck driver advised of the damages. Please contact our office as soon as possible to report damages or shortages so that replacement items can be shipped and the appropriate claims made.
Purchase Orders: Please make purchase orders out to: Xylem Water Solutions USA, Inc.

Terms of delivery: Freight PP/Add Actual
Warranty: Standard warranty terms apply to the items in this quotation.
Validity: This Quote is valid for thirty (30) days.
Taxes: The prices quoted above do not include any state, federal, or local sales tax or use taxes. Any such taxes as applicable must be added to the quoted prices.

Schedule: Delivery lead times are 2-3 weeks after order acceptance.
Terms of payment: Net 30 Standard
Xylem's payment shall not be dependent upon Purchaser being paid by any third party unless Owner denies payment due to reasons solely attributable to items related to the equipment being provided by Xylem Inc.

Terms and Conditions: This order is subject to the Standard Terms and Conditions of Sale - Xylem Americas effective on the date the order is accepted which terms are available at <http://www.xylem.com/en-us/Pages/terms-conditions-of-sale.aspx> and are incorporated herein by reference and made a part of the agreement between the parties

Shortages: Seller will not be responsible for any apparent shipment shortages or damages incurred in shipment that are not reported within two weeks from delivery to the jobsite. Damages should be noted on the receiving slip and the truck driver advised of the damages. Please contact our office as soon as possible to report damages or shortages so that replacement items can be shipped and the appropriate claims made.

Back Charges: Purchaser shall not make purchases nor shall Purchaser incur any labor that would result in a back charge to Seller without prior written consent of an authorized employee of Seller.

Customer Acceptance: A signed facsimile of this quote is acceptance as a binding contract.

Signature: _____

Name (please print) _____

WEDECO
a xylem brand

Page 2 of 3

Date: _____ PO# _____

Sincerely,

A handwritten signature in black ink, appearing to read "Leo Rios", is written over a light blue rectangular background.

Leo Rios
Inside Sales Engineer
Phone: 7048879126

leo.rios@xylem.com

WEDECO
a xylem brand

Page 3 of 3

RESOLUTION NO. 24-133

PASSAIC VALLEY WATER COMMISSION

**RESOLUTION TO PROCURE RENEWAL OF PVWC'S ANNUAL
SOFTWARE MAINTENANCE OF NAVILINE SOFTWARE**

DATE OF ADOPTION: OCTOBER 23, 2024

Introduced by Commissioner: **RIGO SANCHEZ**

Seconded by Commissioner: **JOSEPH KOLODZIEJ**

WHEREAS, Passaic Valley water Commission ("PVWC") previously procured proprietary software and awarded a maintenance contract, in accordance with N.J.S.A. 40A:11-5(dd) relating to proprietary software and/or hardware, to Sungard Public Sector to maintain the said proprietary software system currently in use at PVWC: and

WHEREAS, the previous maintenance contract with Central Square (formerly, Superion, LLC, and before that Sungard Public Sector) is due for renewal by December 4, 2024 for a recommended period of 12-months to provide PVWC with assurance of continuity of service; and

WHEREAS, a copy of the memorandum written by the Director of IT, dated October 10, 2024, recommending the 12-month extension is attached hereto as **Exhibit A**; and

WHEREAS, a copy of the Renewal Orders Q-190184 that includes Central Square's breakdown of applications and related fees, for a total of \$54,165.23, is attached hereto as **Exhibit B**; and

WHEREAS, in accordance with N.J.S.A. 40A:11-12, PVWC may purchase goods or services under contracts entered into on behalf of the State by the Division of Purchase and Property in the Department of the Treasury; and

WHEREAS, PVWC has elected to renew the above-referenced maintenance of PVWC's proprietary software system from Central Square (formerly, Superion, LLC, and before that Sungard Public Sector) of Chicago, Illinois (the "Awardee") in the amount of \$54,165.23 PVWC's

Chief Financial Officer has certified, with respect hereto, that funds are currently available for said purpose and a copy of the said certification is attached hereto and made a part hereof as **Exhibit C**; and

WHEREAS, N.J.S.A. 40A:11-12 of the Local Public Contracts Law provides for the awarding of said contract to the Awardee; and

WHEREAS, the Executive Director, the Director of Engineering, the Director of Purchasing and the Chief Financial Officer have reviewed the above referenced memorandums and concur with the recommendation of the IT Department;

NOW, THEREFORE, BE IT RESOLVED, by Passaic Valley Water Commission, in the County of Passaic, New Jersey:

1. That PVWC hereby awards a 12-month Contract for the renewal of the maintenance of PVWC's proprietary software system to the Awardee in connection with the above-described goods and services in the total amount of \$54,165.23; and
2. That an appropriate official of PVWC, on behalf of PVWC, is hereby authorized and directed to execute the Contract hereby awarded to the Awardee and the Secretary of PVWC to attest to the Contract and such other officers, employees and officials of PVWC are hereby authorized to perform such acts and execute such documents as are necessary to implement the terms and intentions of this Resolution.
3. That this matter shall be advertised as required by New Jersey law, in accordance with an appropriate form of notice, and a copy of this Resolution shall be placed on file and made available for public inspection at the office of the Administrative Secretary of the Passaic Valley Water Commission.

RECORD OF COMMISSION VOTE ON FINAL PASSAGE

| | AYE | NAY | ABSTAIN | ABSENT |
|---------------------------|-----------------|------------|----------------|-----------------|
| SANCHEZ, R. | <u>X</u> | — | — | — |
| COTTON, R. | <u>X</u> | — | — | — |
| DEPADUA, C. | <u>X</u> | — | — | — |
| KOLODZIEJ, J. | <u>X</u> | — | — | — |
| LEVINE, J. | <u>X</u> | — | — | — |
| VAN RENSA LIER, R. | — | — | — | <u>X</u> |
| FRIEND, G. | <u>X</u> | — | — | — |

Adopted at a meeting of Passaic Valley Water Commission.

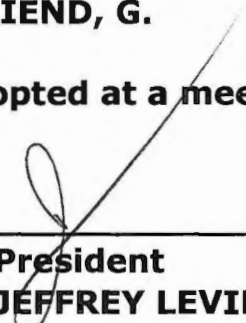

President
JEFFREY LEVINE

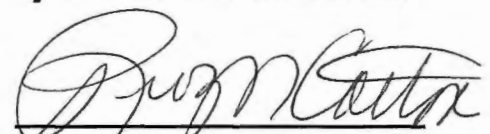

Secretary
RUBY N. COTTON

This Resolution, when adopted, must remain in the custody of the Administrative Secretary.

CERTIFICATION

I, LOUIS AMODIO, Administrative Secretary of the Passaic Valley Water Commission in the County of Passaic, and the State of New Jersey do hereby certify that the foregoing Resolution is a true copy thereof of the foregoing Resolution duly passed and adopted by a majority of a legal quorum of the full membership of the Passaic Valley Water Commission at its duly noticed and convened meeting of the said Commission on October 23, 2024.



LOUIS AMODIO
Administrative Secretary

EXHIBIT A

Passaic Valley Water Commission Inter - Office Memorandum

To: L. Bresemann
From: L. Ducheine
cc: J. Mueller
Date: October 10, 2024
Re: Recommendation to approve Central Square Annual license and support fees for Naviline

The Department of Information Technology recommends the Commission approves renewal fees for the Naviline application. The provided services are:

| | |
|---|--------------------|
| Naviline Modifications annual maintenance | \$300.00 |
| Naviline Accounts Receivable-Annual Maintenance Fee | \$8,825.24 |
| Naviline Cash Receipts-Annual Maintenance Fee | \$6,342.18 |
| Naviline GMBA w/Extended Reporting Annual Maintenance Fee | \$24,981.59 |
| Naviline Purchasing/Inventory-Annual Maintenance Fee | \$13,716.22 |
| Total = | \$54,165.23 |

The requested approval ensures that Naviline is under maintenance support for one year. The Information Technology Dept. recommends that the Board approves the support renewal funds request. These maintenance items are essential for the proper operation of the software package. Our current contracts is set to expire in October 2024. If renewed, the new maintenance contract would be effective for 1 year.

EXHIBIT B



Invoice

Invoice No (1 of 1)
422175

Date
10/7/2024

Page
1 of 2

Superior, LLC, a CentralSquare Company
1000 Business Center Drive
Lake Mary, FL 32746

Billing Inquiries: Accounts.Receivable@centralsquare.com

Bill To
Passaic Valley Water
Lisa Bresemann
1525 Main Avenue
Clifton NJ 07011
United States

Ship To
Passaic Valley Water
Lisa Bresemann
1525 Main Avenue
Clifton NJ 07011
United States

| Customer No | Customer Name | Customer PO # | Currency | Due Date |
|-------------|----------------------|---------------|----------|-----------|
| 2181LG | Passaic Valley Water | | USD | 12/4/2024 |

| Description | Units | Rate | Extended |
|---|-------|-----------|-----------|
| Quote No. Q-190184 | | | |
| 1 NaviLine Work Orders/Facility Management - Annual Maintenance Fee Maintenance: Start:12/5/2024, End: 12/4/2025 | 1 | 0.00 | 0.00 |
| 2 NaviLine Cash Receipts-Annual Maintenance Fee-NSP - Annual Maintenance Fee Maintenance: Start:12/5/2024, End: 12/4/2025 | 1 | 6,342.18 | 6,342.18 |
| 3 NaviLine Purchasing/Inventory-Annual Maintenance Fee-NSP - Annual Maintenance Fee Maintenance: Start:12/5/2024, End: 12/4/2025 | 1 | 13,716.22 | 13,716.22 |
| 4 Modifications - Annual Maintenance Fee Maintenance: Start:12/5/2024, End: 12/4/2025 | 3 | 100.00 | 300.00 |
| 5 NaviLine Accounts Receivable-Annual Maintenance Fee-NSP - Annual Maintenance Fee Maintenance: Start:12/5/2024, End: 12/4/2025 | 1 | 8,825.24 | 8,825.24 |
| 6 NaviLine GMBA w/Extended Reporting - Annual Maintenance Fee Maintenance: Start:12/5/2024, End: 12/4/2025 | 1 | 24,981.59 | 24,981.59 |
| 7 NaviLine Global Financials Annual Maintenance Fee - Annual Maintenance Fee Maintenance: Start:12/5/2024, End: 12/4/2025 | 1 | 0.00 | 0.00 |
| 8 Distribution Services - Annual Maintenance Fee Maintenance: Start:12/5/2024, End: 12/4/2025 | 1 | 0.00 | 0.00 |
| 9 Technical Services - TS - Annual Maintenance Fee Maintenance: Start:12/5/2024, End: 12/4/2025 | 1 | 0.00 | 0.00 |



Invoice

Invoice No (1 of 1)
422175

Date
10/7/2024

Page
2 of 2

Superior, LLC, a CentralSquare Company
1000 Business Center Drive
Lake Mary, FL 32746

Billing Inquiries: Accounts.Receivable@centralsquare.com

Bill To
Passaic Valley Water
Lisa Bresemann
1525 Main Avenue
Clifton NJ 07011
United States

Ship To
Passaic Valley Water
Lisa Bresemann
1525 Main Avenue
Clifton NJ 07011
United States

| <i>Customer No</i> | <i>Customer Name</i> | <i>Customer PO #</i> | <i>Currency</i> | <i>Due Date</i> |
|--------------------|----------------------|----------------------|-----------------|-----------------|
| 2181LG | Passaic Valley Water | | USD | 12/4/2024 |

Please include invoice number(s) on your remittance advice.

ACH:
Routing Number 121000358
Account Number 1416612641
E-mail payment details to: Accounts.Receivable@CentralSquare.com

Check:
12709 Collection Center Drive
Chicago, IL 60693

| | |
|-------------------------|----------------------|
| Subtotal | 54,165.23 |
| Tax | 0.00 |
| Invoice Total | 54,165.23 |
| Payments Applied | 0.00 |
| Balance Due | USD 54,165.23 |

EXHIBIT C

OFFICE OF THE COMPTROLLER

CERTIFICATION OF AVAILABILITY OF FUNDS

It is hereby certified that subject to Commission approval of future Budgets, with respect to multi-budget year contracts, there are or will be sufficient available funds for expenditures to be incurred as result of any contract or commitment to be entered into by Passaic Valley Water Commission as follows:

Description of Project or Contract: Annual Subscription - Central Square
Annual License and Support Fees Naviline

Amount of Project or Contract: \$54,165.23

1. Account # 001-0604-416-70-52
IT: Purchases/Maintenance and Licensing Agreements
2. Specific appropriation to which expenditures will be charged:
BUDFGET – 2024/2025

Other comments: Twelve (12) Month Contract Commencing December 4, 2024

Date of Certification: October 16, 2024

Amount Certified: \$54,165.23

Yitzchak Weiss
Comptroller and Chief Financial Officer

YW:lb

RESOLUTION NO. 24-134

PASSAIC VALLEY WATER COMMISSION

**RESOLUTION TO PROCURE ONE (1) BOBCAT
COMPACT EXCAVATOR E60 R2 SERIES UNDER
BERGEN COUNTY PURCHASING COOPERATIVE**

DATE OF ADOPTION: OCTOBER 23, 2024

Introduced by Commissioner: **RIGO SANCHEZ**

Seconded by Commissioner: **JOSEPH KOLODZIEJ**

WHEREAS, the Commission needs to procure one (1) Bobcat Compact Excavator E60 R2 Series to allow the Distribution crews to replace inoperable curb stops and assist performing repairs on main breaks; and

WHEREAS, the Bergen County Purchasing Cooperative Group #CK-04, Grounds Division 22-09 (the "Cooperative") shall be used for the procurement of said Excavator; and

WHEREAS, in accordance with N.J.S.A. 40A:11-12, PVWC may purchase goods or services under contracts entered into on behalf of the State by the Division of Purchase and Property in the Department of the Treasury; and

WHEREAS, PVWC has elected to procure the above-referenced loader from Bobcat of North Jersey of Totowa, NJ (the "Awardee") under the Cooperative, in the amount of \$97,420.00 a copy of the quotation for the vehicle is attached hereto as **Exhibit A**; and

WHEREAS, N.J.S.A. 40A:11-12 of the Local Public Contracts Law provides for the awarding of said contract to the Awardee; and

WHEREAS, PVWC's Chief Financial Officer has certified, with respect hereto, that funds are currently available for said purpose and a copy of the said certification is attached hereto and made a part hereof as **Exhibit B**.

NOW, THEREFORE, BE IT RESOLVED, by Passaic Valley Water Commission, in the County of Passaic, New Jersey;

1. That the Cooperative Pricing Agreement for procurement of the above-referenced Excavator is hereby awarded to the Awardee as set forth hereinabove; and
2. That the appropriate officers and employees of PVWC are hereby authorized and directed to perform such acts and execute such documents as are consistent herewith, with respect to the Cooperative Pricing Agreement as set forth hereinabove.

RECORD OF COMMISSION VOTE ON FINAL PASSAGE

| | AYE | NAY | ABSTAIN | ABSENT |
|--------------------------|-----------------|------------|----------------|-----------------|
| VAN RENSALIER, R. | — | — | — | <u>X</u> |
| COTTON, R. | <u>X</u> | — | — | — |
| SANCHEZ, R. | <u>X</u> | — | — | — |
| KOLODZIEJ, J. | <u>X</u> | — | — | — |
| DEPADUA, C. | <u>X</u> | — | — | — |
| FRIEND, G. | <u>X</u> | — | — | — |
| LEVINE, J. | <u>X</u> | — | — | — |

Adopted at a meeting of Passaic Valley Water Commission.

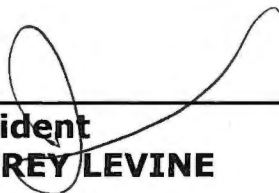

President
JEFFREY LEVINE



Secretary
RUBY N. COTTON

This Resolution, when adopted, must remain in the custody of the Administrative Secretary.

CERTIFICATION

I, LOUIS AMODIO, Administrative Secretary of the Passaic Valley Water Commission in the County of Passaic, and the State of New Jersey do hereby certify that the foregoing Resolution is a true copy thereof of the foregoing Resolution duly passed and adopted by a majority of a legal quorum of the full membership of the Passaic Valley Water Commission at its duly noticed and convened meeting of the said Commission on October 23, 2024.

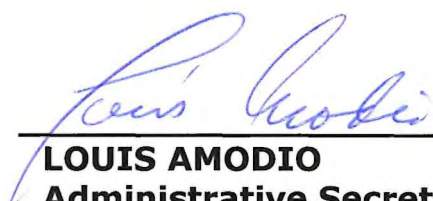

LOUIS AMODIO
Administrative Secretary

EXHIBIT A



Product Quotation
 Quotation Number: **PB788478**
 Quote Sent Date: **Oct 10, 2024**
 Expiration Date: **Nov 09, 2024**

Your Bobcat Contact
Patrick Barckett
 Phone: +12014460127
 Email: patrick.barckett@njbobcat.com

Your Customer Contact

Deliver to
Bobcat of North Jersey, Totowa, NJ
 201 MALTESE DRIVE
 TOTOWA, NJ, 07512

Bobcat Dealer
Bobcat of North Jersey, Totowa, NJ
 201 MALTESE DRIVE
 TOTOWA, NJ, 07512

Bill to
Bobcat of North Jersey, Totowa, NJ
 201 MALTESE DRIVE
 TOTOWA, NJ, 07512

| Item Name | Item Number | Quantity | Price Each | Total |
|---|---------------|----------|--|-----------|
| E60 R2-Series Bobcat Compact Excavator | M3321 | 1 | 72,815.00 | 72,815.00 |
| Standard Equipment: | | | | |
| 55.7 HP | | | Horn | |
| Turbocharged, Bobcat 2.4L, Tier 4 Diesel Engine, Non-DPF | | | Hydraulic Joystick Controls | |
| Auto-Idle | | | Keyless Start | |
| Auto-Shift, Two-Speed Travel | | | LED Work Lights | |
| Auxiliary Hydraulics with Selectable Flow | | | Lift Eye | |
| w/ Arm Mounted Flush Face Quick Couplers | | | Long Arm | |
| Canopy: | | | Rubber Tracks | |
| Includes: Cup Holder, Retractable Seat Belt, Vinyl Suspension Seat | | | Spark Arrestor | |
| Roll Over Protective Structure (ROPS) - Meets Requirements of ISO 12117-2: 2008 | | | Deluxe Instrument Panel | |
| Tip Over Protective Structure (TOPS) - Meets Requirements of ISO 12117: 2000 | | | Vandalism Protection | |
| Falling Object Protective Structure (FOPS) - Meets Requirements of ISO 10262 | | | X-Change Attachment Mounting System | |
| Control Console Locks | | | Telematics with 2-year Machine IQ Basics Subscription +90-Day Machine IQ Health & Security Trial | |
| Control Pattern Selector Valve (ISO/STD) | | | Warranty: 2 years, or 2000 hours whichever occurs first | |
| Conventional Tail Swing | | | | |
| Dozer Blade with Float | | | | |
| Engine/Hydraulic Monitor with Shutdown | | | | |
| Fingertip Auxiliary Hydraulic Control | | | | |
| Fingertip Boom Swing Control | | | | |
| Cab Deluxe Package | M3321-P11-C12 | 1 | 13,389.00 | 13,389.00 |
| <i>Included: Cab Deluxe Package:, Enclosed Cab with Auto HVAC, Telematics with 3-year Machine IQ Health & Security Subscription, Keyless Start, Bobcat 7" Touch Display with Radio and Bluetooth, Heated High Back Cloth Suspension Seat, Travel Motion Alarm</i> | | | | |
| Hydraulic Clamp - Long Arm - Class IV w/ Diverter Valve | M3321-R08-C15 | 1 | 3,987.00 | 3,987.00 |
| Hydraulic X-Change - Long Arm | M3321-R06-C04 | 1 | 2,458.00 | 2,458.00 |

| | | | | |
|--|---------------|---|----------|----------|
| Long Arm + Additional Bolt-on Counterweight | M3321-R03-C09 | 1 | 1,783.00 | 1,783.00 |
| 24" MX4 XCHG TEETH | 7311868 | 1 | 1,711.00 | 1,711.00 |
| 12" MX4 XCHG TEETH | 7321974 | 1 | 1,277.00 | 1,277.00 |

Total for E60 R2-Series Bobcat Compact Excavator 97,420.00

| | |
|--------------------------|------------------|
| Quote Total - USD | 97,420.00 |
| Dealer P.D.I. | 0.00 |
| Freight Charges | 0.00 |
| Destination Charges | 0.00 |
| Sales total before Taxes | 97,420.00 |
| Taxes | 0.00 |
| Quote Total - USD | 97,420.00 |

| | |
|------------------------------|--|
| Customer acceptance: | |
| Quotation Number:: PB788478 | Purchase Order: _____ |
| Authorized Signature: | |
| Print: _____ | Sign: _____ |
| Date: _____ | Email: _____ Tax Exempt: Y <input type="checkbox"/> / N <input type="checkbox"/> |

Pricing thru the Bergen County Co-op Buying Group #CK-04, Grounds Division 22-09.

EXHIBIT B

OFFICE OF THE COMPTROLLER

CERTIFICATION OF AVAILABILITY OF FUNDS

It is hereby certified that subject to Commission approval of future Budgets, with respect to multi-budget year contracts, there are or will be sufficient available funds for expenditures to be incurred as result of any contract or commitment to be entered into by Passaic Valley Water Commission as follows:

Description of Project or Contract: Bobcat of North Jersey
Under Bergen County Cooperative
Buying Group #CK-04/Grounds Division 22-09

Amount of Project or Contract: \$97,420.00

1. Acct: #- 001-0901-419-95-06
CAPITAL/EQUIPMENT & MACHINERY
2. Specific Appropriation to which expenditures will be charged:
Capital Budget 2024/2025

Other comments: Single Purchase Under Cooperative –
Bergen County Cooperative
One (1) E60 R2-Series Bobcat Compact Excavator

Date of Certification: October 16, 2024 Certified: \$97,420.00

Yitzchak Weiss
Comptroller and Chief Financial Officer

YW:lb

RESOLUTION NO. 24-135

PASSAIC VALLEY WATER COMMISSION

**RESOLUTION TO PROCURE FIVE (5) 2024 GMC TK-10753
1500 SIERRA DOUBLE CAB PICKUP 4X4 TRUCKS
FROM COOPERATIVE PRICING COOPERATIVE**

DATE OF ADOPTION: OCTOBER 23, 2024

Introduced by Commissioner: **RIGO SANCHEZ**

Seconded by Commissioner: **JOSEPH KOLODZIEJ**

WHEREAS, the Commission needs to procure five (5) 2024 GMC TK-10753 1500 Sierra Double Cab Pickup 4X4 Trucks to replace trucks in the Distribution and Engineering Departments that are at the end of their useful life; and

WHEREAS, the ESCNJ Cooperative #22/23-12, (the "Cooperative") shall be used for the procurement of said 2024 GMC TK-10753 1500 Sierra Double Cab Pickup 4X4 Trucks; and

WHEREAS, in accordance with N.J.S.A. 40A:11-12, PVWC may purchase goods or services under contracts entered into on behalf of the State by the Division of Purchase and Property in the Department of the Treasury; and

WHEREAS, PVWC has elected to procure the above-referenced Trucks from Frank's Truck Center of Lyndhurst, New Jersey (the "Awardee") under the Cooperative, with the cost of each vehicle being \$50,940.60 for a total amount of \$254,703.00 a copy of the quotation for the vehicle is attached hereto as **Exhibit A**; and

WHEREAS, N.J.S.A. 40A:11-12 of the Local Public Contracts Law provides for the awarding of said contract to the Awardee; and

WHEREAS, PVWC's Chief Financial Officer has certified, with respect hereto, that funds are currently available for said purpose and a copy of the said certification is attached hereto and made a part hereof as **Exhibit B**.

NOW, THEREFORE, BE IT RESOLVED, by Passaic Valley Water Commission, in the County of Passaic, New Jersey;

1. That the Cooperative Pricing Agreement for procurement of the above-referenced Trucks is hereby awarded to the Awardee as set forth hereinabove; and
2. That the appropriate officers and employees of PVWC are hereby authorized and directed to perform such acts and execute such documents as are consistent herewith, with respect to the Cooperative Pricing Agreement as set forth hereinabove.

RECORD OF COMMISSION VOTE ON FINAL PASSAGE

| | AYE | NAY | ABSTAIN | ABSENT |
|---------------------------|---------------------|---------------|----------------|---------------------|
| VAN RENSA LIER, R. | <u> </u> | <u> </u> | <u> </u> | <u> X </u> |
| COTTON, R. | <u> X </u> | <u> </u> | <u> </u> | <u> </u> |
| SANCHEZ, R. | <u> X </u> | <u> </u> | <u> </u> | <u> </u> |
| KO LODZIEJ, J. | <u> X </u> | <u> </u> | <u> </u> | <u> </u> |
| DE PADUA, C. | <u> X </u> | <u> </u> | <u> </u> | <u> </u> |
| FRIEND, G. | <u> X </u> | <u> </u> | <u> </u> | <u> </u> |
| LEVINE, J. | <u> X </u> | <u> </u> | <u> </u> | <u> </u> |

Adopted at a meeting of Passaic Valley Water Commission.



President
JEFFREY LEVINE



Secretary
RUBY N. COTTON

This Resolution, when adopted, must remain in the custody of the Administrative Secretary.

CERTIFICATION

I, LOUIS AMODIO, Administrative Secretary of the Passaic Valley Water Commission in the County of Passaic, and the State of New Jersey do hereby certify that the foregoing Resolution is a true copy thereof of the foregoing Resolution duly passed and adopted by a majority of a legal quorum of the full membership of the Passaic Valley Water Commission at its duly noticed and convened meeting of the said Commission on October 23, 2024.

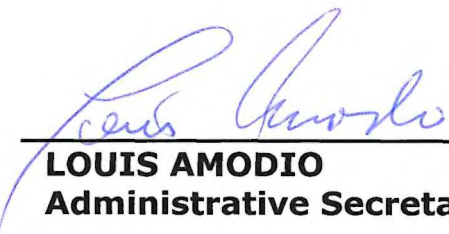

LOUIS AMODIO
Administrative Secretary

EXHIBIT A



ESCNJ PARTICIPANT
Passaic Valley Water Commission
 1525 Main Ave.
 Clifton, NJ 07011
 Michael Marotta - 973-340-4300 973-768-4655
mmarotta@pvwc.com

ESCNJ VENDOR
Frank's Truck Center
 325 Orient Way
 Lyndhurst, NJ 07071
 (201)939-7708
 Guy Montaina
gmontaina@frankstruckcenter.com

**NJ State Approved ESCNJ Co-Op #65 MCESCCPS – Cars, Crossovers, Class 1-3 Trucks/Chassis/SUV and Vans
 Bid – ESCNJ# 23/24-11**

**2024 GMC TK10753 – 1500 Sierra Double Cab Pick Up 4x4 147 Inch Wheelbase – 1SA PRO Package – 6.5 Foot
 Pickup Bed**

Date of Request – September 16, 2024

Vehicle in Stock – VIN – 1GTRUAED8RZ296021 – Stock Number - 64965

Request for Quote Approval Confirmation Number _____

| | |
|--------------------------------|-------------|
| | MSRP |
| Base Price | \$44,300.00 |
| Destination Charge | \$ 1,995.00 |
| | <hr/> |
| Total Base Plus Destination | \$46,295.00 |
| Discount – 5% | \$ 2,314.75 |
| Base Adjusted | \$43,980.25 |
| Options | \$ 7,470.00 |
| Discount – 9.5% | \$ 709.65 |
| Options Adjusted | \$ 6,760.35 |
| Base Adjusted | \$43,980.25 |
| Options Adjusted | \$ 6,780.35 |
| Delivery to Passaic County | \$ 180.00 |
| Total Delivered Contract Price | \$50,940.60 |

Vehicle in Stock – VIN – 1GTRUAED8RZ296021 – Stock Number - 64965

EXHIBIT B

OFFICE OF THE COMPTROLLER

CERTIFICATION OF AVAILABILITY OF FUNDS

It is hereby certified that subject to Commission approval of future Budgets, with respect to multi-budget year contracts, there are or will be sufficient available funds for expenditures to be incurred as result of any contract or commitment to be entered into by Passaic Valley Water Commission as follows:

Description of Project or Contract: Frank's Truck Center of Lyndhurst
Under ESCNJ #22/23-12

Amount of Project or Contract: \$254,703.00

1. Acct: #- 001-0901-419-95-04 - CAPITAL/VEHICLES
2. Specific Appropriation to which expenditures will be charged:
Capital Budget 2023/2024

Other comments: Single Purchase Under Cooperative – ESCNJ #22/23-12
Five (5) 2024 GMC TK10753 1500 Sierra Double Cab Pickup Trucks
Each Vehicle: \$50,940.60 for a total of \$254,703.00

Date of Certification: October 16, 2024 Certified: \$254,703.00

Yitzchak Weiss
Comptroller and Chief Financial Officer

YW:lb

RESOLUTION NO. 24-136

PASSAIC VALLEY WATER COMMISSION

**RESOLUTION TO PROCURE FOUR (4)
2024 GMC SAVANA 2500 CARGO VANS
FROM COOPERATIVE PRICING COOPERATIVE**

DATE OF ADOPTION: OCTOBER 23, 2024

Introduced by Commissioner: **RIGO SANCHEZ**

Seconded by Commissioner: **JOSEPH KOLODZIEJ**

WHEREAS, the Commission needs to procure four (4) 2024 GMC Savana 2500 Cargo Vans to replace vehicles in the Distribution and Maintenance Departments that are at the end of their useful life; and

WHEREAS, the ESCNJ Cooperative #22/23-12, (the "Cooperative") shall be used for the procurement of said 2024 GMC Savana 2500 Cargo Vans; and

WHEREAS, in accordance with N.J.S.A. 40A:11-12, PVWC may purchase goods or services under contracts entered into on behalf of the State by the Division of Purchase and Property in the Department of the Treasury; and

WHEREAS, PVWC has elected to procure the above-referenced Vans from Frank's Truck Center of Lyndhurst, New Jersey (the "Awardee") under the Cooperative, with the cost of each vehicle being \$44,132.16 for a total amount of \$176,528.64 a copy of the quotation for the vehicles is attached hereto as **Exhibit A**; and

WHEREAS, N.J.S.A. 40A:11-12 of the Local Public Contracts Law provides for the awarding of said contract to the Awardee; and

WHEREAS, PVWC's Chief Financial Officer has certified, with respect hereto, that funds are currently available for said purpose and a copy of the said certification is attached hereto and made a part hereof as **Exhibit B**.

NOW, THEREFORE, BE IT RESOLVED, by Passaic Valley Water Commission, in the County of Passaic, New Jersey;

1. That the Cooperative Pricing Agreement for procurement of the above-referenced Vans is hereby awarded to the Awardee as set forth hereinabove; and
2. That the appropriate officers and employees of PVWC are hereby authorized and directed to perform such acts and execute such documents as are consistent herewith, with respect to the Cooperative Pricing Agreement as set forth hereinabove.

RECORD OF COMMISSION VOTE ON FINAL PASSAGE

| | AYE | NAY | ABSTAIN | ABSENT |
|---------------------------|---------------------|---------------|----------------|---------------------|
| VAN RENSA LIER, R. | <u> </u> | <u> </u> | <u> </u> | <u> X </u> |
| COTTON, R. | <u> X </u> | <u> </u> | <u> </u> | <u> </u> |
| SANCHEZ, R. | <u> X </u> | <u> </u> | <u> </u> | <u> </u> |
| KOLODZIEJ, J. | <u> X </u> | <u> </u> | <u> </u> | <u> </u> |
| DEPADUA, C. | <u> X </u> | <u> </u> | <u> </u> | <u> </u> |
| FRIEND, G. | <u> X </u> | <u> </u> | <u> </u> | <u> </u> |
| LEVINE, J. | <u> X </u> | <u> </u> | <u> </u> | <u> </u> |

Adopted at a meeting of Passaic Valley Water Commission.



President
JEFFREY LEVINE

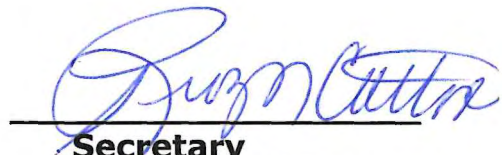

Secretary
RUBY N. COTTON

This Resolution, when adopted, must remain in the custody of the Administrative Secretary.

CERTIFICATION

I, LOUIS AMODIO, Administrative Secretary of the Passaic Valley Water Commission in the County of Passaic, and the State of New Jersey do hereby certify that the foregoing Resolution is a true copy thereof of the foregoing Resolution duly passed and adopted by a majority of a legal quorum of the full membership of the Passaic Valley Water Commission at its duly noticed and convened meeting of the said Commission on October 23, 2024.

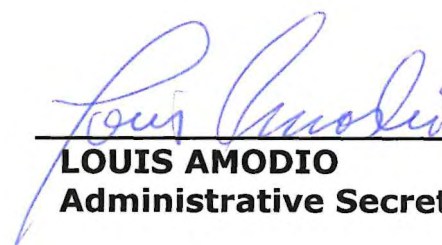

LOUIS AMODIO
Administrative Secretary

EXHIBIT A



ESCNJ PARTICIPANT
Passaic Valley Water Commission
 1525 Main Ave.
 Clifton, NJ 07011
 Michael Marotta - 973-340-4300 973-768-4655
mmarotta@pvwc.com

ESCNJ VENDOR
Frank's Truck Center
 325 Orient Way
 Lyndhurst, NJ 07071
 (201)939-7708
 Guy Montaina
gmontaina@frankstruckcenter.com

**NJ State Approved ESCNJ Co-Op #65 MCECCPS – Cars, Crossovers, Class 1-3 Trucks/Chassis/SUV and Vans
 Bid – ESCNJ# 23/24-11**

2024 GMC TG23405 - 2500 Cargo Van – 1WT Package 135 Inch Wheelbase

This Vehicle is In-Stock – 1GTW7AF73R1187838 – Stock #66349

Date of Request – October 14, 2024

Request for Quote Approval Confirmation Number _____

| | MSRP |
|--|-------------|
| Base Price | \$40,700.00 |
| Destination Charge | \$ 1,895.00 |
| Base Total | \$42,595.00 |
| Discount – 6.6% | \$ 2,811.27 |
| Base Adjusted | \$39,783.73 |
| Options | \$ 4,606.00 |
| Discount – 9.5% | \$ 437.57 |
| Options Adjusted | \$ 4,168.43 |
| Base Adjusted | \$39,783.73 |
| Options Adjusted | \$ 4,168.43 |
| Vehicle Delivery Charge Passaic County | \$ 180.00 |
| Total Delivered Contract Price | \$44,132.16 |

This Vehicle is In-Stock – 1GTW7AF73R1187838 – Stock #66349

EXHIBIT B

OFFICE OF THE COMPTROLLER

CERTIFICATION OF AVAILABILITY OF FUNDS

It is hereby certified that subject to Commission approval of future Budgets, with respect to multi-budget year contracts, there are or will be sufficient available funds for expenditures to be incurred as result of any contract or commitment to be entered into by Passaic Valley Water Commission as follows:

Description of Project or Contract: Frank's Truck Center of Lyndhurst
Under ESCNJ #22/23-12

Amount of Project or Contract: \$176,528.64

1. Acct: #- 001-0901-419-95-04 - CAPITAL/VEHICLES
2. Specific Appropriation to which expenditures will be charged:
Capital Budget 2024/2025

Other comments: Single Purchase Under Cooperative – ESCNJ #22/23-12
Four (4) 2024 GMC Savana 2500 Cargo Van
Each Vehicle: \$44,132.16 for a total of \$176,528.64

Date of Certification: October 16, 2024 Certified: \$176,528.64

Yitzhak Weiss
Comptroller and Chief Financial Officer

YW:lb

RESOLUTION NO. 24-137

PASSAIC VALLEY WATER COMMISSION

**RESOLUTION TO PROCURE THREE (3)
2024 GMC ACADIA ELEVATION AWD VEHICLES
FROM COOPERATIVE PRICING COOPERATIVE**

DATE OF ADOPTION: OCTOBER 23, 2024

Introduced by Commissioner: **RIGO SANCHEZ**

Seconded by Commissioner: **JOSEPH KOLODZIEJ**

WHEREAS, the Commission needs to procure three (3) 2024 GMC Acadia AWD Vehicles to replace vehicles in the Distribution and Pump Station Departments that are at the end of their useful life; and

WHEREAS, the ESCNJ Cooperative #22/23-12, (the "Cooperative") shall be used for the procurement of said 2024 GMC Acadia Elevation AWD Vehicles; and

WHEREAS, in accordance with N.J.S.A. 40A:11-12, PVWC may purchase goods or services under contracts entered into on behalf of the State by the Division of Purchase and Property in the Department of the Treasury; and

WHEREAS, PVWC has elected to procure the above-referenced Vehicles from Frank's Truck Center of Lyndhurst, New Jersey (the "Awardee") under the Cooperative, with the cost of each vehicle being \$45,406.25 for a total amount of \$136,218.75 a copy of the quotation for the Vehicles is attached hereto as **Exhibit A**; and

WHEREAS, N.J.S.A. 40A:11-12 of the Local Public Contracts Law provides for the awarding of said contract to the Awardee; and

WHEREAS, PVWC's Chief Financial Officer has certified, with respect hereto, that funds are currently available for said purpose and a copy of the said certification is attached hereto and made a part hereof as **Exhibit B**.

NOW, THEREFORE, BE IT RESOLVED, by Passaic Valley Water Commission, in the County of Passaic, New Jersey;

1. That the Cooperative Pricing Agreement for procurement of the above-referenced Vehicles is hereby awarded to the Awardee as set forth hereinabove; and
2. That the appropriate officers and employees of PVWC are hereby authorized and directed to perform such acts and execute such documents as are consistent herewith, with respect to the Cooperative Pricing Agreement as set forth hereinabove.

RECORD OF COMMISSION VOTE ON FINAL PASSAGE

| | AYE | NAY | ABSTAIN | ABSENT |
|---------------------------|-----------------|------------|----------------|-----------------|
| VAN RENSA LIER, R. | — | — | — | <u>X</u> |
| COTTON, R. | <u>X</u> | — | — | — |
| SANCHEZ, R. | <u>X</u> | — | — | — |
| KO LODZIEJ, J. | <u>X</u> | — | — | — |
| DE PADUA, C. | <u>X</u> | — | — | — |
| FRIEND, G. | <u>X</u> | — | — | — |
| LEVINE, J. | <u>X</u> | — | — | — |

Adopted at a meeting of Passaic Valley Water Commission.

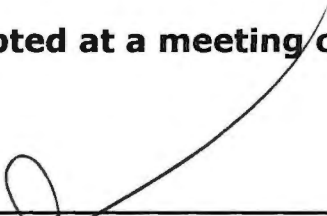

President
JEFFREY LEVINE



Secretary
RUBY N. COTTON

This Resolution, when adopted, must remain in the custody of the Administrative Secretary.

CERTIFICATION

I, LOUIS AMODIO, Administrative Secretary of the Passaic Valley Water Commission in the County of Passaic, and the State of New Jersey do hereby certify that the foregoing Resolution is a true copy thereof of the foregoing Resolution duly passed and adopted by a majority of a legal quorum of the full membership of the Passaic Valley Water Commission at its duly noticed and convened meeting of the said Commission on October 23, 2024.

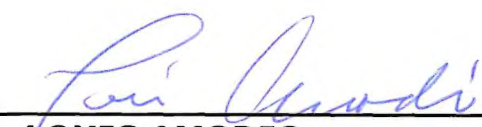

LOUIS AMODIO
Administrative Secretary

EXHIBIT A



ESCNJ PARTICIPANT
Passaic Valley Water Commission
1525 Main Ave.
Clifton, NJ 07011
Michael Marotta - 973-340-4300 973-768-4655
mmarotta@pvwc.com

ESCNJ VENDOR
Frank's Truck Center
325 Orient Way
Lyndhurst, NJ 07071
(201)939-7708
Guy Montaina
gmontaina@frankstruckcenter.com

NJ State Approved ESCNJ Co-Op #65 MCESCCPS – Cars, Crossovers, Class 1-3 Trucks/Chassis/SUV and Vans
Bid – ESCNJ# 23/24-11

2024 GMC Acadia – AWD Elevation 4SD Package – Model TLD56

Vehicle in Stock #66669 – VIN – 1GKENNKS2RJ195730

Date of Request – October 14, 2024

Request for Quote Approval Confirmation Number _____

| | |
|---|--------------------|
| | MSRP |
| Base Price | \$44,600.00 |
| Destination Charge | \$ 1,395.00 |
| Total Base Price | <u>\$45,995.00</u> |
| Discount - 5.4% | \$ 2,483.73 |
| Adjusted Base Price | <u>\$43,511.27</u> |
| Options Price | \$ 1,895.00 |
| Options Price Discount – 9.5% | \$ 180.02 |
| Adjusted Options Price | <u>\$ 1,714.98</u> |
| Adjusted Base Price | \$43,511.27 |
| Adjusted Options Price | \$ 1,714.98 |
| Delivery to Passaic County | \$ 180.00 |
| Total Delivered Contract Price Acadia Elevation Only | \$45,406.25 |

Vehicle in Stock #66669 – VIN – 1GKENNKS2RJ195730

EXHIBIT B

OFFICE OF THE COMPTROLLER

CERTIFICATION OF AVAILABILITY OF FUNDS

It is hereby certified that subject to Commission approval of future Budgets, with respect to multi-budget year contracts, there are or will be sufficient available funds for expenditures to be incurred as result of any contract or commitment to be entered into by Passaic Valley Water Commission as follows:

Description of Project or Contract: Frank's Truck Center of Lyndhurst
Under ESCNJ #22/23-12

Amount of Project or Contract: \$136,218.75

1. Acct: #- 001-0901-419-95-04 - CAPITAL/VEHICLES
2. Specific Appropriation to which expenditures will be charged:
Capital Budget 2024/2025

Other comments: Single Purchase Under Cooperative – ESCNJ #22/23-12
Three (3) 2024 Acadia Elevation AWD Vehicles
Each Vehicle: \$45,406.25 for a total of \$136,218.75

Date of Certification: October 16, 2024 Certified: \$136,218.75

Yitzchak Weiss
Comptroller and Chief Financial Officer

YW:lb

RESOLUTION NO. 24-138

PASSAIC VALLEY WATER COMMISSION

**RESOLUTION TO PROCURE FOUR (4)
2024 GMC TERRAIN SLE AWD MODEL TXB26 VEHICLES
FROM COOPERATIVE PRICING COOPERATIVE**

DATE OF ADOPTION: OCTOBER 23, 2024

Introduced by Commissioner: **RIGO SANCHEZ**

Seconded by Commissioner: **JOSEPH KOLODZIEJ**

WHEREAS, the Commission needs to procure four (4) 2024 GMC Terrain SLE AWD Model TXB26 Vehicles to replace vehicles in the Laboratory and Purification Departments that are at the end of their useful life; and

WHEREAS, the ESCNJ Cooperative #22/23-12, (the "Cooperative") shall be used for the procurement of said 2024 GMC Terrain SLE AWD Model TXB26 Vehicles; and

WHEREAS, in accordance with N.J.S.A. 40A:11-12, PVWC may purchase goods or services under contracts entered into on behalf of the State by the Division of Purchase and Property in the Department of the Treasury; and

WHEREAS, PVWC has elected to procure the above-referenced Vehicles from Frank's Truck Center of Lyndhurst, New Jersey (the "Awardee") under the Cooperative, with the cost of each vehicle being \$32,348.98 for a total amount of \$129,395.92 a copy of the quotation for the Vehicles is attached hereto as **Exhibit A**; and

WHEREAS, N.J.S.A. 40A:11-12 of the Local Public Contracts Law provides for the awarding of said contract to the Awardee; and

WHEREAS, PVWC's Chief Financial Officer has certified, with respect hereto, that funds are currently available for said purpose and a copy of the said certification is attached hereto and made a part hereof as **Exhibit B**.

NOW, THEREFORE, BE IT RESOLVED, by Passaic Valley Water Commission, in the County of Passaic, New Jersey;

1. That the Cooperative Pricing Agreement for procurement of the above-referenced Vehicles is hereby awarded to the Awardee as set forth hereinabove; and
2. That the appropriate officers and employees of PVWC are hereby authorized and directed to perform such acts and execute such documents as are consistent herewith, with respect to the Cooperative Pricing Agreement as set forth hereinabove.

RECORD OF COMMISSION VOTE ON FINAL PASSAGE

| | AYE | NAY | ABSTAIN | ABSENT |
|---------------------------|---------------------|---------------|----------------|---------------------|
| VAN RENSA LIER, R. | <u> </u> | <u> </u> | <u> </u> | <u> X </u> |
| COTTON, R. | <u> X </u> | <u> </u> | <u> </u> | <u> </u> |
| SANCHEZ, R. | <u> X </u> | <u> </u> | <u> </u> | <u> </u> |
| KO LODZIEJ, J. | <u> X </u> | <u> </u> | <u> </u> | <u> </u> |
| DE PADUA, C. | <u> X </u> | <u> </u> | <u> </u> | <u> </u> |
| FRIEND, G. | <u> X </u> | <u> </u> | <u> </u> | <u> </u> |
| LEVINE, J. | <u> X </u> | <u> </u> | <u> </u> | <u> </u> |

Adopted at a meeting of Passaic Valley Water Commission.



President
JEFFREY LEVINE



Secretary
RUBY N. COTTON

This Resolution, when adopted, must remain in the custody of the Administrative Secretary.

CERTIFICATION

I, LOUIS AMODIO, Administrative Secretary of the Passaic Valley Water Commission in the County of Passaic, and the State of New Jersey do hereby certify that the foregoing Resolution is a true copy thereof of the foregoing Resolution duly passed and adopted by a majority of a legal quorum of the full membership of the Passaic Valley Water Commission at its duly noticed and convened meeting of the said Commission on October 23, 2024.

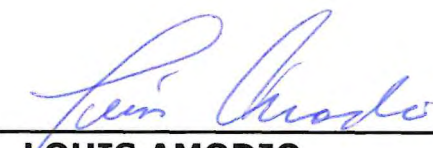

LOUIS AMODIO
Administrative Secretary

EXHIBIT A



ESCNJ PARTICIPANT

Passaic Valley Water Commission
1525 Main Ave.
Clifton, NJ 07011
Michael Marotta - 973-340-4300 973-768-4655
mmarotta@pvwc.com

ESCNJ VENDOR

Frank's Truck Center
325 Orient Way
Lyndhurst, NJ 07071
(201)939-7708
Guy Montaina
gmontaina@frankstruckcenter.com

**NJ State Approved ESCNJ Co-Op #65 MCESSCCPS – Cars, Crossovers, Class 1-3 Trucks/Chassis/SUV and Vans
Bid – ESCNJ# 23/24-11**

2024 GMC Terrain – Model – TXB26 – from Stock – VIN – 3GKALTEG3RL256348 – Stock #64718

Date of Request – October 14, 2024

Request for Quote Approval Confirmation Number _____

| | |
|--|-----------------------------|
| | MSRP |
| Vehicle Base Price | \$30,300.00 |
| Destination Fee | \$ 1,395.00 |
| | <hr/> |
| Total Base Price | \$31,695.00 |
| Discount Off from Lot – Inventory – 5.7% | \$ 1,806.62 |
| | <hr/> |
| Adjusted Base Vehicle Price | \$29,888.38 |
| | <hr/> |
| Option MSRP | \$ 2,520.00 |
| Discount Off Option Content 9.5% | \$ 239.40 |
| | <hr/> |
| Adjusted Option Price | \$ 2,280.60 |
| | <hr/> |
| Adjusted Base Vehicle Price | \$29,888.38 |
| Adjusted Option Price | \$ 2,280.60 |
| Delivery to Passaic County | \$ 180.00 |
| | <hr/> |
| Total Delivered Contract Price | \$32,348.98 Per Unit |

Vehicle in Stock – 2024 GMC Terrain – Model – TXB26 – VIN – 3GKALTEG3RL256348 – Stock #64718

(Similar to the Equinox)

EXHIBIT B

OFFICE OF THE COMPTROLLER

CERTIFICATION OF AVAILABILITY OF FUNDS

It is hereby certified that subject to Commission approval of future Budgets, with respect to multi-budget year contracts, there are or will be sufficient available funds for expenditures to be incurred as result of any contract or commitment to be entered into by Passaic Valley Water Commission as follows:

Description of Project or Contract: Frank's Truck Center of Lyndhurst
Under ESCNJ #22/23-12

Amount of Project or Contract: \$129,395.92

1. Acct: #- 001-0901-419-95-04 - CAPITAL/VEHICLES
2. Specific Appropriation to which expenditures will be charged:
Capital Budget 2024/2025

Other comments: Single Purchase Under Cooperative – ESCNJ #22/23-12
Four (4) 2024 Terrain SLE AWD Vehicles
Each Vehicle: \$32,348.98 for a total of \$129,395.92

Date of Certification: October 16, 2024 Certified: \$129,395.92

Yitzhak Weiss
Comptroller and Chief Financial Officer

YW:lb
