



PASSAIC VALLEY WATER COMMISSION

RESOLUTION #26-EXE-2

RESOLUTION OF PASSAIC VALLEY WATER COMMISSION

DATE OF ADOPTION: MARCH 25, 2026

Factual Contents certified to by Louis Amodio, Administrative Secretary. Approved as to Form and Legality on basis of facts set forth by Yaacov Brisman, General Counsel. Entering Executive Closed Session in accordance with Open Public Meetings Act, R.S. 10:4-6 et seq. Pursuant to the Open Public Meetings Act,

COMMISSIONER: RON VAN RENSALIER offers the following Resolution for adoption:

WHEREAS, Section 8 of the Open Public Meetings Act, c. 231, P.L. 1975, permits the exclusion of the public from a meeting in certain circumstances; and

WHEREAS the public body is of the opinion that such circumstances presently exist:

NOW, THEREFORE, BE IT RESOLVED, by the Commissioners of Passaic Valley Water Commission:

- 1. The public shall be excluded from discussion of the hereinafter specified Subject Matters; Contracts, Security, Negotiations, Personnel, Law and: other matters as may be discussed *in camera*.**
- 2. It is anticipated at this time that the above-stated subject matters will be Ratified During public meeting following or as soon thereafter as the reason for discussion no Longer exists.**
- 3. This Resolution shall take effect immediately.**

Second by **COMMISSIONER: RUBY N. COTTON Time: 10:31 am**

RECORD OF COMMISSION VOTE ON FINAL PASSAGE

	AYE	NAY	ABSTAIN	ABSENT
COTTON, R.	X			
DEPADUA, C.	X			
FRIEND, G.	X			
LEVINE, J.	X			
SANCHEZ, R.	X			
VAN RENSALIER, R.	X			
RIZZI, D.	X			

Adopted at a meeting of Passaic Valley Water Commission.



President
DEB RIZZI



Secretary
RUBY N. COTTON



PASSAIC VALLEY WATER COMMISSION

This Resolution, when adopted, must remain in the custody of the Administrative Secretary.

CERTIFICATION

I, LOUIS AMODIO, Administrative Secretary of the Passaic Valley Water Commission in the County of Passaic, and the State of New Jersey do hereby certify that the foregoing Resolution is a true copy of a legal quorum of the Original Resolution duly passed and adopted by a majority of the full membership of the Passaic Valley Water Commission at its meeting of MARCH 25, 2026.

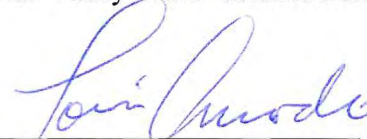

LOUIS AMODIO
Administrative Secretary

RESOLUTION NO. 26-042

PASSAIC VALLEY WATER COMMISSION

**RESOLUTION TO AWARD CONTRACT NO. 26-V-16
ENTITLED "HOT MIX ASPHALT"**

DATE OF ADOPTION: MARCH 25, 2026

Introduced by Commissioner: **RON VAN RENSALIER**

Seconded by Commissioner: **RUBY N. COTTON**

WHEREAS, on March 17, 2026, one (1) bid was received by Passaic Valley Water Commission ("PVWC") for Contract No. 26-V-16 entitled "Hot Mix Asphalt"; and

WHEREAS, the lowest responsible, responsive bid submitted for this contract was that of Tilcon New York Inc. of Parsippany, New Jersey (the "Awardee") with respect to said bid, in the amount of \$774,175.00 for a period of two (2) years; and

WHEREAS, the bids have been reviewed by the Engineering Department and the Director of Purchasing, and a copy of the said bid tabulation sheet is attached hereto and made a part hereof as **Exhibit A**; and

WHEREAS, the Local Public Contracts Law provides for award of the Contract upon receipt of bids and qualifications of bidders therefor; and

WHEREAS, PVWC's Chief Financial Officer has certified, with respect hereto, that funds are currently available for said purpose and a copy of the said certification is attached hereto and made a part hereof as **Exhibit B**;

NOW, THEREFORE, BE IT RESOLVED, by Passaic Valley Water Commission, in the County of Passaic, New Jersey:

1. That PVWC hereby awards the Contract to the Awardee in accordance with N.J.S.A. 40A:11-1 et seq. and N.J.S.A. 19:44A-20.7, and in accordance with said Response, as set forth hereinabove; and

2. That an appropriate official of PVWC, on behalf of PVWC, is hereby authorized and directed to execute the Contract hereby awarded to the Awardee and the Secretary of PVWC to attest to the Contract and such other officers, employees and officials of PVWC are hereby authorized to perform such acts and execute such documents as are necessary to implement the terms and intentions of this Resolution; and

RECORD OF COMMISSION VOTE ON FINAL PASSAGE

	AYE	NAY	ABSTAIN	ABSENT
COTTON, R.	<u>X</u>	___	___	___
DEPADUA, C.	<u>X</u>	___	___	___
FRIEND, G.	<u>X</u>	___	___	___
LEVINE, J.	<u>X</u>	___	___	___
SANCHEZ, R.	<u>X</u>	___	___	___
VAN RENSALIER, R.	<u>X</u>	___	___	___
RIZZI, D.	<u>X</u>	___	___	___

Adopted at a meeting of Passaic Valley Water Commission.



DEBORAH RIZZI
 President



RUBY N. COTTON
 Secretary

This Resolution, when adopted, must remain in the custody of the Administrative Secretary.

CERTIFICATION

I, LOUIS AMODIO, Administrative Secretary of the Passaic Valley Water Commission in the County of Passaic, and the State of New Jersey do hereby certify that the foregoing Resolution is a true copy thereof of the foregoing Resolution duly passed and adopted by a majority of a legal quorum of the full membership of the Passaic Valley Water Commission at its duly noticed and convened meeting of the said Commission on March 25, 2026.

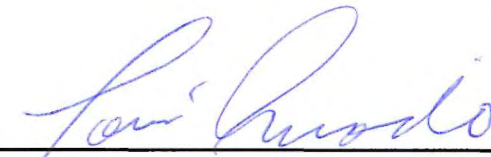

LOUIS AMODIO
 Administrative Secretary

EXHIBIT A

Title: HOT MIX ASPHALT

Contract # 26-V-16

Bid Tabulation Evaluation

Bid Opening Date: MARCH 17, 2026 at 2:00 PM

BIDDERS	BID DEPOSIT	TOTAL AMOUNT OF CONTRACT	REMARKS
Tilcon New York, Inc. 9 Entin Road Parsippany, NJ 07054	<input type="checkbox"/> Certified Check	\$774,175.00	<input checked="" type="checkbox"/> Business Registration Cert.
	<input type="checkbox"/> Cashier's Check		<input checked="" type="checkbox"/> PVWC Consent of Surety
	<input checked="" type="checkbox"/> Bid Bond 10%		<input type="checkbox"/> Other Consent of Surety
	<input checked="" type="checkbox"/> Not to Exceed \$20K		<input checked="" type="checkbox"/> Public Works Cont. Cert.
			<input checked="" type="checkbox"/> EEO
	<input type="checkbox"/> Certified Check		<input type="checkbox"/> Business Registration Cert.
	<input type="checkbox"/> Cashier's Check		<input type="checkbox"/> PVWC Consent of Surety
	<input type="checkbox"/> Bid Bond 10%		<input type="checkbox"/> Other Consent of Surety
	<input type="checkbox"/> Not to Exceed 20K		<input type="checkbox"/> Public Works Cont. Cert.
			<input type="checkbox"/> EEO
	<input type="checkbox"/> Certified Check		<input type="checkbox"/> Business Registration Cert.
	<input type="checkbox"/> Cashier's Check		<input type="checkbox"/> PVWC Consent of Surety
	<input type="checkbox"/> Bid Bond 10%		<input type="checkbox"/> Other Consent of Surety
	<input type="checkbox"/> Not to Exceed \$20K		<input type="checkbox"/> Public Works Cont. Cert.
			<input type="checkbox"/> EEO
	<input type="checkbox"/> Certified Check		<input type="checkbox"/> Business Registration Cert.
	<input type="checkbox"/> Cashier's Check		<input type="checkbox"/> PVWC Consent of Surety
	<input type="checkbox"/> Bid Bond 10%		<input type="checkbox"/> Other Consent of Surety
	<input type="checkbox"/> Not to Exceed 20K		<input type="checkbox"/> Public Works Cont. Cert.
			<input type="checkbox"/> EEO
	<input type="checkbox"/> Certified Check		<input type="checkbox"/> Business Registration Cert.
	<input type="checkbox"/> Cashier's Check		<input type="checkbox"/> PVWC Consent of Surety
	<input type="checkbox"/> Bid Bond 10%		<input type="checkbox"/> Other Consent of Surety
	<input type="checkbox"/> Not to Exceed 20K		<input type="checkbox"/> Public Works Cont. Cert.
			<input type="checkbox"/> EEO

EXHIBIT B

OFFICE OF THE COMPTROLLER

CERTIFICATION OF AVAILABILITY OF FUNDS

It is hereby certified that subject to Commission approval of future Budgets, with respect to multi-budget year contracts, there are or will be sufficient available funds for expenditures to be incurred as a result of any contract or commitment to be entered into by Passaic Valley Water Commission as follows:

Description of Project or Contract: Contract No.: 26-V-16
"Hot Mix Asphalt"
Tilcon New York, Inc.

Amount of Project or Contract: \$774,175.00

1. Acct: #- 001-3002-424-43-05
BUDGET – MATERIALS/STREET RESURFACE
2. Specific Appropriation to which expenditures will be charged:
BUDGET 2026/2027/2028 – 2 Year Contract

Date of Certification: March 25, 2026

Certified: \$774,175.00

Yitzchak Weiss
Comptroller and Chief Financial Officer

YW:lb

RESOLUTION NO. 26-043

PASSAIC VALLEY WATER COMMISSION

**RESOLUTION AWARDED PROJECT 26-PA-09 ENTITLED
"PROFESSIONAL SERVICES FOR SEARCH CONSULTANT FOR THE
EXECUTIVE DIRECTOR POSITION"**

DATE OF ADOPTION: MARCH 25, 2026

Introduced by Commissioner: **RON VAN RENSA LIER**

Seconded by Commissioner: **RUBY N. COTTON**

WHEREAS, on February 25, 2026, Executive Director James Mueller provided notice to the Board of his intention to resign from Passaic Valley Water Commission ("PVWC"); and

WHEREAS, PVWC is desirous of hiring a new Executive Director for the position and has solicited for Extraordinary Unspecifiable Services ("EUSs") for Contract No. 26-PA-09 entitled "Professional Services for Search Consultant for the Executive Director position" (hereinafter the "Project"); and

WHEREAS, said Contract shall be awarded as an EUS under the Non-Fair and Open Process and N.J.S.A. 40A:11-5(1)(a)(i) for providing professional services for a professional search consultant to conduct a search for candidates for the position of Executive Director; and

WHEREAS, the firm of The Giddings Group, of Fort Myers, Florida (the "Awardee") was determined to be professionally qualified and capable of performing the required services with respect to the Project, at the cost not to exceed \$75,000; and

WHEREAS, it is in the best interest of PVWC, its users and constituent municipalities to engage, or continue to engage, the services of the Awardee at this time; and

WHEREAS, PVWC's Chief Financial Officer has certified, with respect hereto, that funds are currently available for said purpose and a copy of the said certification is attached hereto and made a part hereof as **Exhibit A**.

NOW, THEREFORE, BE IT RESOLVED, by Passaic Valley Water Commission, in the County of Passaic, New Jersey:

1. That PVWC hereby awards the Contract to the Awardee in accordance with N.J.S.A. 40A:11-5(1)(a)(i) and N.J.S.A. 19:44A-1 et seq. as set forth hereinabove; and
2. That an appropriate official of PVWC, on behalf of PVWC, is hereby authorized and directed to execute the Contract hereby awarded to the Awardee and the Secretary of PVWC to attest to the Contract and such other officers, employees and officials of PVWC are hereby authorized to perform such acts and execute such documents as are necessary to implement the terms and intentions of this Resolution; and
3. That this matter shall be advertised as required by New Jersey law, in accordance with an appropriate form of notice, and a copy of this Resolution and Agreement shall be placed on file and made available for inspection at the office of the Administrative Secretary of Passaic Valley Water Commission.

RECORD OF COMMISSION VOTE ON FINAL PASSAGE

	AYE	NAY	ABSTAIN	ABSENT
COTTON, R.	<u>X</u>	—	—	—
DEPADUA, C.	<u>X</u>	—	—	—
FRIEND, G.	<u>X</u>	—	—	—
LEVINE, J.	<u>X</u>	—	—	—
SANCHEZ, R.	<u>X</u>	—	—	—
VAN RENSA LIER, R.	<u>X</u>	—	—	—
RIZZI, D.	<u>X</u>	—	—	—

Adopted at a meeting of Passaic Valley Water Commission.



DEBORAH RIZZI
President



RUBY N. COTTON
Secretary

This Resolution, when adopted, must remain in the custody of the Administrative Secretary.

CERTIFICATION

I, LOUIS AMODIO, Administrative Secretary of the Passaic Valley Water Commission in the County of Passaic, and the State of New Jersey do hereby certify that the foregoing Resolution is a true copy thereof of the foregoing Resolution duly passed and adopted by a majority of a legal quorum of the full membership of the Passaic Valley Water Commission at its duly noticed and convened meeting of the said Commission on March 25, 2026.



LOUIS AMODIO
Administrative Secretary

EXHIBIT A

RESOLUTION # 26-044

RESOLUTION OF PASSAIC VALLEY WATER COMMISSION

**RESOLUTION TO PROCURE RENEWAL OF PVWC'S ANNUAL
SUBSCRIPTION OF ENTERPRISE SOFTWARE UNDER THE NEW
JERSEY COOPERATIVE PURCHASING ALLIANCE CONTRACT NO.
CK04, SUBCONTRACT NO. 24-38**

DATE OF ADOPTION: MARCH 25, 2026

Introduced by Commissioner: **RON VAN RENSALIER**

Seconded by Commissioner: **RUBY N. COTTON**

WHEREAS, PVWC utilizes the CISCO SmartNet Networking Licenses for their Enterprise Subscription Software which allows PVWC to conduct business safely and securely. This software must be renewed annually; and

WHEREAS, PVWC is desirous of renewing this software subscription for a period of three years rather than a one-year renewal and would receive significant savings for doing so; and

WHEREAS, the PVWC seeks to procure the software renewal using the New Jersey Cooperative Purchasing Alliance (the "Co-op"), State Contract Number CK04, Subcontract No. 24-38, as described on Quotation Number 27168223, which is attached hereto as **EXHIBIT A**; and

WHEREAS, in accordance with N.J.S.A. 40A:11-12, PVWC may purchase goods or services under contracts entered into on behalf of the State by the Division of Purchase and Property in the Department of the Treasury; and

WHEREAS, PVWC has elected to procure the above-referenced network equipment from SHI International Corp., of Somerset, New Jersey (the "Awardee") under the State Contract, in the amount of \$1,241,792.31, a copy of a memorandum dated February 27, 2026 from

the Director of the IT Department, which is attached hereto as **EXHIBIT B**, and the Financial Certification along with other relevant correspondence, is attached hereto and made a part hereof as **EXHIBIT C**; and

WHEREAS, N.J.S.A. 40A:11-12 of the Local Public Contracts Law provides for the awarding of said contract to the Awardee; and

WHEREAS, the Executive Director, the Director of Engineering, and the Chief Financial Officer have reviewed the above-referenced memorandums and concur with the recommendation of the IT Department;

NOW, THEREFORE, BE IT RESOLVED, by Passaic Valley Water Commission, in the County of Passaic, New Jersey;

1. That the Purchasing Cooperative for procurement of the above-referenced licenses is hereby awarded to the Awardee as set forth hereinabove; and
2. That the appropriate officers and employees of PVWC are hereby authorized and directed to perform such acts and execute such documents as are consistent herewith, with respect to the State Contract as set forth hereinabove.

RECORD OF COMMISSION VOTE ON FINAL PASSAGE

	AYE	NAY	ABSTAIN	ABSENT
COTTON, R.	<u>X</u>	---	---	---
DEPADUA, C.	<u>X</u>	---	---	---
FRIEND, G.	<u>X</u>	---	---	---
LEVINE, J.	<u>X</u>	---	---	---
SANCHEZ, R.	<u>X</u>	---	---	---
VAN RENSA LIER, R.	<u>X</u>	---	---	---
RIZZI, D.	<u>X</u>	---	---	---

Adopted at a meeting of Passaic Valley Water Commission.



DEBORAH RIZZI
President



RUBY N. COTTON
Secretary

This Resolution, when adopted, must remain in the custody of the Administrative Secretary.

CERTIFICATION

I, LOUIS AMODIO, Administrative Secretary of the Passaic Valley Water Commission in the County of Passaic, and the State of New Jersey do hereby certify that the foregoing Resolution is a true copy thereof of the foregoing Resolution duly passed and adopted by a majority of a legal quorum of the full membership of the Passaic Valley Water Commission at its duly noticed and convened meeting of the said Commission on March 25, 2026.

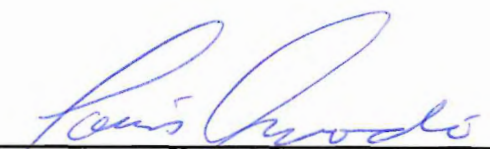

LOUIS AMODIO
Administrative Secretary

EXHIBIT A



Pricing Proposal
 Quotation #: 27168223
 Created On: 2/13/2026
 Valid Until: 3/5/2026

NJ-City of Passaic Valley Water Commission

Account Executive

Eric Coan
 1525 Main Avenue
 PO Box 230
 Clifton, NJ 07011
 United States
 Phone: (973) 340-4300
 Fax: (973) 340-5598
 Email: ecoan@pvwc.com

Nick Sgroi
 300 Davidson Avenue
 Somerset, NJ 08873
 Phone: 800-527-6389 ext:8688756
 Fax: 732-868-8757
 Email: Nick_Sgroi@shi.com

All Prices are in US Dollar (USD)

Product	Qty	Your Price	Total
1 Infrastructure Services SaaS/CVA - Advantage Cisco Systems - Part#: DC-MGT-IS-SAAS-AD Contract Name: New Jersey Cooperative Purchasing Alliance Contract #: CK04 Subcontract #: 24-38	8	\$1,724.30	\$13,794.40
2 ENH SW SUB Cisco Systems - Part#: CON-L1SWT-C93A48 Contract Name: New Jersey Cooperative Purchasing Alliance Contract #: CK04 Subcontract #: 24-38 Coverage Term: 6/22/2026 - 7/20/2026	22	\$13.28	\$292.16
3 ENH 8X7XNCDOS Cisco Systems - Part#: CON-L1NCO-UCSCSC22 Contract Name: New Jersey Cooperative Purchasing Alliance Contract #: CK04 Subcontract #: 24-38 Coverage Term: 9/24/2027 - 2/28/2029	1	\$1,055.18	\$1,055.18
4 ENH 8X5XNBD Cisco Systems - Part#: CON-L1NBD-C9300XZ4 Contract Name: New Jersey Cooperative Purchasing Alliance Contract #: CK04 Subcontract #: 24-38 Coverage Term: 5/21/2028 - 2/28/2029	8	\$745.83	\$5,966.64
5 ENH 8X5XNBD Cisco Systems - Part#: CON-L1NBD-C9532ACQ Contract Name: New Jersey Cooperative Purchasing Alliance Contract #: CK04 Subcontract #: 24-38 Coverage Term: 3/1/2026 - 2/28/2029	5	\$7,151.77	\$35,758.85
6 ENH 24X7X4 Cisco Systems - Part#: CON-L14HR-C95024YA Contract Name: New Jersey Cooperative Purchasing Alliance	5	\$2,196.57	\$10,982.85

Contract #: CK04
 Subcontract #: 24-38
 Coverage Term: 5/14/2026 – 2/28/2029

7	ENH 8X5XNBD Cisco Systems - Part#: CON-L1NBD-FPR21GFN Contract Name: New Jersey Cooperative Purchasing Alliance Contract #: CK04 Subcontract #: 24-38 Coverage Term: 3/1/2026 – 2/28/2029	2	\$6,808.41	\$13,616.82
8	ENH 24X7X4 Cisco Systems - Part#: CON-L14HR-IR101K9K Contract Name: New Jersey Cooperative Purchasing Alliance Contract #: CK04 Subcontract #: 24-38 Coverage Term: 2/28/2026 – 2/28/2029	50	\$568.54	\$28,427.00
9	ENH SW SUB Cisco Systems - Part#: CON-L1SWT-C93A48 Contract Name: New Jersey Cooperative Purchasing Alliance Contract #: CK04 Subcontract #: 24-38 Coverage Term: 6/28/2026 – 2/28/2029	4	\$446.98	\$1,787.92
10	ENH 24X7X4 Cisco Systems - Part#: CON-L14HR-IE32008E Contract Name: New Jersey Cooperative Purchasing Alliance Contract #: CK04 Subcontract #: 24-38 Coverage Term: 6/17/2026 – 2/28/2029	10	\$1,325.40	\$13,254.00
11	ENH 8X5XNBD Cisco Systems - Part#: CON-L1NBD-C9300XZ4 Contract Name: New Jersey Cooperative Purchasing Alliance Contract #: CK04 Subcontract #: 24-38 Coverage Term: 8/13/2026 – 2/28/2029	6	\$2,442.30	\$14,653.80
12	ENH 24X7X4 Cisco Systems - Part#: CON-L14HR-FPR21FWN Contract Name: New Jersey Cooperative Purchasing Alliance Contract #: CK04 Subcontract #: 24-38 Coverage Term: 3/1/2026 – 2/28/2029	2	\$5,988.42	\$11,976.84
13	ENH 24X7X4 Cisco Systems - Part#: CON-L14HR-FPR21FWN Contract Name: New Jersey Cooperative Purchasing Alliance Contract #: CK04 Subcontract #: 24-38 Coverage Term: 6/8/2026 – 2/28/2029	2	\$5,447.00	\$10,894.00
14	ENH 24X7X4 Cisco Systems - Part#: CON-L14HR-C95024YA Contract Name: New Jersey Cooperative Purchasing Alliance Contract #: CK04 Subcontract #: 24-38 Coverage Term: 3/1/2026 – 2/28/2029	6	\$8,265.41	\$49,592.46
15	ENH 24X7X4 Cisco Systems - Part#: CON-L14HR-IE32008E	20	\$1,470.43	\$29,408.60

Contract Name: New Jersey Cooperative Purchasing Alliance
 Contract #: CK04
 Subcontract #: 24-38
 Coverage Term: 3/1/2026 – 2/28/2029

16	ENH 24X7X4 Cisco Systems - Part#: CON-L14HR-IR101K9K Contract Name: New Jersey Cooperative Purchasing Alliance Contract #: CK04 Subcontract #: 24-38 Coverage Term: 3/1/2026 – 2/28/2029	41	\$566.99	\$23,246.59
17	ENH 8X5XNBD Cisco Systems - Part#: CON-L1NBD-CSCAM1ZC Contract Name: New Jersey Cooperative Purchasing Alliance Contract #: CK04 Subcontract #: 24-38 Coverage Term: 1/9/2029 – 2/28/2029	2	\$142.45	\$284.90
18	ENH SW SUB Cisco Systems - Part#: CON-L1SWT-C9524YCA Contract Name: New Jersey Cooperative Purchasing Alliance Contract #: CK04 Subcontract #: 24-38 Coverage Term: 2/26/2026 – 3/26/2026	3	\$25.00	\$75.00
19	ENH SW SUB Cisco Systems - Part#: CON-L1SWT-C93A48 Contract Name: New Jersey Cooperative Purchasing Alliance Contract #: CK04 Subcontract #: 24-38 Coverage Term: 8/13/2026 – 9/10/2026	3	\$13.28	\$39.84
20	ENH 8X5XNBD Cisco Systems - Part#: CON-L1NBD-FCM1600K Contract Name: New Jersey Cooperative Purchasing Alliance Contract #: CK04 Subcontract #: 24-38 Coverage Term: 3/1/2026 – 11/30/2028	1	\$11,834.19	\$11,834.19
21	ENH 8X5XNBD Cisco Systems - Part#: CON-L1NBD-C9300XZ4 Contract Name: New Jersey Cooperative Purchasing Alliance Contract #: CK04 Subcontract #: 24-38 Coverage Term: 7/29/2026 – 2/28/2029	13	\$2,481.70	\$32,262.10
22	ENH 8X5XNBD Cisco Systems - Part#: CON-L1NBD-CS1VMCK9 Contract Name: New Jersey Cooperative Purchasing Alliance Contract #: CK04 Subcontract #: 24-38 Coverage Term: 1/9/2029 – 2/28/2029	1	\$27.98	\$27.98
23	ENH 8X5XNBD Cisco Systems - Part#: CON-L1NBD-C83002PA Contract Name: New Jersey Cooperative Purchasing Alliance Contract #: CK04 Subcontract #: 24-38 Coverage Term: 6/23/2026 – 2/28/2029	46	\$1,243.72	\$57,211.12
24	ENH 24X7X4OS	8	\$5,116.64	\$40,933.12

Cisco Systems - Part#: CON-L14OS-HXAF24CX
 Contract Name: New Jersey Cooperative Purchasing Alliance
 Contract #: CK04
 Subcontract #: 24-38
 Coverage Term: 4/22/2026 -- 2/28/2029

25	ENH SW SUB	3	\$425.91	\$1,277.73
Cisco Systems - Part#: CON-L1SWT-C93A48 Contract Name: New Jersey Cooperative Purchasing Alliance Contract #: CK04 Subcontract #: 24-38 Coverage Term: 8/13/2026 -- 2/28/2029				
26	ENH 8X5XNBD	2	\$10,519.83	\$21,039.66
Cisco Systems - Part#: CON-L1NBD-FPR2130W Contract Name: New Jersey Cooperative Purchasing Alliance Contract #: CK04 Subcontract #: 24-38 Coverage Term: 3/1/2026 -- 2/28/2029				
27	ENH SW SUB	4	\$42.60	\$170.40
Cisco Systems - Part#: CON-L1SWT-C9532QCA Contract Name: New Jersey Cooperative Purchasing Alliance Contract #: CK04 Subcontract #: 24-38 Coverage Term: 3/1/2026 -- 3/29/2026				
28	ENH 8X5XNBD	3	\$1,980.78	\$5,942.34
Cisco Systems - Part#: CON-L1NBD-IE40104S Contract Name: New Jersey Cooperative Purchasing Alliance Contract #: CK04 Subcontract #: 24-38 Coverage Term: 7/27/2026 -- 2/28/2029				
29	ENH SW SUB	5	\$6.71	\$33.55
Cisco Systems - Part#: CON-L1SWT-IE40104H Contract Name: New Jersey Cooperative Purchasing Alliance Contract #: CK04 Subcontract #: 24-38 Coverage Term: 7/27/2026 -- 8/24/2026				
30	ENH SW SUB	3	\$432.79	\$1,298.37
Cisco Systems - Part#: CON-L1SWT-C93A48 Contract Name: New Jersey Cooperative Purchasing Alliance Contract #: CK04 Subcontract #: 24-38 Coverage Term: 7/29/2026 -- 2/28/2029				
31	ENH 8X5XNBD	4	\$4,170.67	\$16,682.68
Cisco Systems - Part#: CON-L1NBD-HC1F4M6 Contract Name: New Jersey Cooperative Purchasing Alliance Contract #: CK04 Subcontract #: 24-38 Coverage Term: 2/16/2027 -- 2/28/2029				
32	ENH 8X5XNBD	5	\$5,637.88	\$28,189.40
Cisco Systems - Part#: CON-L1NBD-C9504YA4 Contract Name: New Jersey Cooperative Purchasing Alliance Contract #: CK04 Subcontract #: 24-38 Coverage Term: 2/26/2026 -- 2/28/2029				

33	ENH 8X5XNBD Cisco Systems - Part#: CON-L1NBD-C9200C88 Contract Name: New Jersey Cooperative Purchasing Alliance Contract #: CK04 Subcontract #: 24-38 Coverage Term: 12/24/2028 - 2/28/2029	1	\$28.47	\$28.47
34	ENH 8X5XNBD Cisco Systems - Part#: CON-L1SNB-IE40104S Contract Name: New Jersey Cooperative Purchasing Alliance Contract #: CK04 Subcontract #: 24-38 Coverage Term: 7/27/2026 - 2/28/2029	2	\$1,980.78	\$3,961.56
35	ENH SW SUB Cisco Systems - Part#: CON-L1SWT-C93A48 Contract Name: New Jersey Cooperative Purchasing Alliance Contract #: CK04 Subcontract #: 24-38 Coverage Term: 7/29/2026 - 8/26/2026	10	\$13.28	\$132.80
36	ENH SW SUB Cisco Systems - Part#: CON-L1SWT-C93A48 Contract Name: New Jersey Cooperative Purchasing Alliance Contract #: CK04 Subcontract #: 24-38 Coverage Term: 6/28/2026 - 7/26/2026	1	\$13.28	\$13.28
37	ENH SW SUB Cisco Systems - Part#: CON-L1SWT-C9548Y4A Contract Name: New Jersey Cooperative Purchasing Alliance Contract #: CK04 Subcontract #: 24-38 Coverage Term: 2/26/2026 - 3/26/2026	5	\$42.60	\$213.00
38	ENH 24X7X4 Cisco Systems - Part#: CON-L14HR-IE32008E Contract Name: New Jersey Cooperative Purchasing Alliance Contract #: CK04 Subcontract #: 24-38 Coverage Term: 3/13/2028 - 2/28/2029	20	\$1,454.32	\$29,086.40
39	ENH 8X7XNCD Cisco Systems - Part#: CON-L1NCD-C85012X5 Contract Name: New Jersey Cooperative Purchasing Alliance Contract #: CK04 Subcontract #: 24-38 Coverage Term: 2/26/2026 - 2/28/2029	2	\$33,496.56	\$66,993.12
40	ENH SW SUB Cisco Systems - Part#: CON-L1SWT-C93A24 Contract Name: New Jersey Cooperative Purchasing Alliance Contract #: CK04 Subcontract #: 24-38 Coverage Term: 6/23/2026 - 7/21/2026	46	\$7.06	\$324.76
41	ENH 8X5XNBD Cisco Systems - Part#: CON-L1NBD-C93004PA Contract Name: New Jersey Cooperative Purchasing Alliance Contract #: CK04 Subcontract #: 24-38 Coverage Term: 6/28/2026 - 2/28/2029	5	\$2,096.09	\$10,480.45

42	ENH 24X7X4 Cisco Systems - Part#: CON-L14HR-C9500Q24 Contract Name: New Jersey Cooperative Purchasing Alliance Contract #: CK04 Subcontract #: 24-38 Coverage Term: 3/1/2026 – 2/28/2029	3	\$13,260.86	\$39,782.58
43	ENH 24X7X4 Cisco Systems - Part#: CON-L14HR-E401016S Contract Name: New Jersey Cooperative Purchasing Alliance Contract #: CK04 Subcontract #: 24-38 Coverage Term: 3/1/2026 – 2/28/2029	10	\$3,451.22	\$34,512.20
44	ENH 8X5XNBD Cisco Systems - Part#: CON-L1NBD-C95024YA Contract Name: New Jersey Cooperative Purchasing Alliance Contract #: CK04 Subcontract #: 24-38 Coverage Term: 2/26/2026 – 2/28/2029	3	\$5,180.33	\$15,540.99
45	ENH SW SUB Cisco Systems - Part#: CON-L1SWT-C9532QCA Contract Name: New Jersey Cooperative Purchasing Alliance Contract #: CK04 Subcontract #: 24-38 Coverage Term: 3/1/2026 – 2/28/2029	1	\$1,608.36	\$1,608.36
46	ENH 8X5XNBD Cisco Systems - Part#: CON-L1NBD-C93004PA Contract Name: New Jersey Cooperative Purchasing Alliance Contract #: CK04 Subcontract #: 24-38 Coverage Term: 6/22/2026 – 2/28/2029	22	\$2,108.97	\$46,397.34
47	C9200CX 8-port CISCO DNA EA Essentials Cisco Systems - Part#: E3N-C9200CX1-E Contract Name: New Jersey Cooperative Purchasing Alliance Contract #: CK04 Subcontract #: 24-38 Coverage Term: 4/1/2026 – 3/31/2029 Note: True Forward pricing per unit per year: \$43.23	1	\$29.34	\$29.34
48	C9300 24-port CISCO DNA EA Advantage Cisco Systems - Part#: E3N-C93001-A Contract Name: New Jersey Cooperative Purchasing Alliance Contract #: CK04 Subcontract #: 24-38 Coverage Term: 4/1/2026 – 3/31/2029 Note: True Forward pricing per unit per year: \$285.05	46	\$762.56	\$35,077.76
49	C9300 48-port CISCO DNA EA Advantage Cisco Systems - Part#: E3N-C93002-A Contract Name: New Jersey Cooperative Purchasing Alliance Contract #: CK04 Subcontract #: 24-38 Coverage Term: 4/1/2026 – 3/31/2029 Note: True Forward pricing per unit per year: \$534.63	54	\$1,221.44	\$65,957.76
50	C9300L 24-port CISCO DNA EA Advantage Cisco Systems - Part#: E3N-C9300L1-A	3	\$855.00	\$2,565.00

Contract Name: New Jersey Cooperative Purchasing Alliance
 Contract #: CK04
 Subcontract #: 24-38
 Coverage Term: 4/1/2026 – 3/31/2029
 Note: True Forward pricing per unit per year: \$284.96

51	C9300L 48-port CISCO DNA EA Advantage Cisco Systems - Part#: E3N-C9300L2-A Contract Name: New Jersey Cooperative Purchasing Alliance Contract #: CK04 Subcontract #: 24-38 Coverage Term: 4/1/2026 – 3/31/2029 Note: True Forward pricing per unit per year: \$534.59	2	\$1,603.95	\$3,207.90
52	C9500 CISCO DNA EA Advantage High (24Q/40X) Cisco Systems - Part#: E3N-C95001-A Contract Name: New Jersey Cooperative Purchasing Alliance Contract #: CK04 Subcontract #: 24-38 Coverage Term: 4/1/2026 – 3/31/2029 Note: True Forward pricing per unit per year: \$1,715.79	3	\$5,147.21	\$15,441.63
53	C9500 CISCO DNA EA Advantage 32QC Cisco Systems - Part#: E3N-C95004-A Contract Name: New Jersey Cooperative Purchasing Alliance Contract #: CK04 Subcontract #: 24-38 Coverage Term: 4/1/2026 – 3/31/2029 Note: True Forward pricing per unit per year: \$1,715.79	5	\$5,147.21	\$25,736.05
54	C9500 CISCO DNA EA Advantage 48Y4C Cisco Systems - Part#: E3N-C95005-A Contract Name: New Jersey Cooperative Purchasing Alliance Contract #: CK04 Subcontract #: 24-38 Coverage Term: 4/1/2026 – 3/31/2029 Note: True Forward pricing per unit per year: \$1,715.79	5	\$5,147.21	\$25,736.05
55	C9500 CISCO DNA EA Advantage 24Y4C Cisco Systems - Part#: E3N-C95006-A Contract Name: New Jersey Cooperative Purchasing Alliance Contract #: CK04 Subcontract #: 24-38 Coverage Term: 4/1/2026 – 3/31/2029 Note: True Forward pricing per unit per year: \$1,006.77	14	\$2,062.62	\$28,876.68
56	WAN (Routing & SD-WAN) Tier 1 Cloud (250M) DNA EA Advantage Cisco Systems - Part#: E3N-ENTWAN-C-T1-A Contract Name: New Jersey Cooperative Purchasing Alliance Contract #: CK04 Subcontract #: 24-38 Coverage Term: 4/1/2026 – 3/31/2029 Note: True Forward pricing per unit per year: \$614.43	90	\$1,843.43	\$165,908.70
57	WAN (Routing & SD-WAN) Tier 3 Cloud (10G) DNA Advantage Cisco Systems - Part#: E3N-ENTWAN-C-T3-A Contract Name: New Jersey Cooperative Purchasing Alliance Contract #: CK04 Subcontract #: 24-38 Coverage Term: 4/1/2026 – 3/31/2029 Note: True Forward pricing per unit per year: \$4,608.04	2	\$13,824.00	\$27,848.00

58	WAN (Routing & SD-WAN) Tier 3 On-Prem (10G) DNA Advantage Cisco Systems - Part#: E3N-ENTWAN-P-T3-A Contract Name: New Jersey Cooperative Purchasing Alliance Contract #: CK04 Subcontract #: 24-38 Coverage Term: 4/1/2026 – 3/31/2029 Note: True Forward pricing per unit per year: \$4,608.04	2	\$13,824.00	\$27,648.00
59	IE 4010 CISCO DNA EA Advantage Cisco Systems - Part#: E3N-IE4010H-A Contract Name: New Jersey Cooperative Purchasing Alliance Contract #: CK04 Subcontract #: 24-38 Coverage Term: 4/1/2026 – 3/31/2029 Note: True Forward pricing per unit per year: \$289.39	15	\$770.06	\$11,550.90
60	Security EA 3.0 Secure Client Premier Cisco Systems - Part#: E3S-AC-APEX Contract Name: New Jersey Cooperative Purchasing Alliance Contract #: CK04 Subcontract #: 24-38 Coverage Term: 4/1/2026 – 3/31/2029	100	\$8.73	\$873.00
61	Security EA 3.0 FPR2110 Threat Defense Threat, Malware,URL Cisco Systems - Part#: E3S-SFW-FPR2110T Contract Name: New Jersey Cooperative Purchasing Alliance Contract #: CK04 Subcontract #: 24-38 Coverage Term: 4/1/2026 – 3/31/2029 Note: True Forward pricing per unit per year: \$2,260.16	2	\$6,400.53	\$12,801.06
62	Security EA 3.0 FPR2120 Threat Defense Threat, Malware,URL Cisco Systems - Part#: E3S-SFW-FPR2120T Contract Name: New Jersey Cooperative Purchasing Alliance Contract #: CK04 Subcontract #: 24-38 Coverage Term: 4/1/2026 – 3/31/2029 Note: True Forward pricing per unit per year: \$4,109.84	2	\$12,329.51	\$24,659.02
63	Security EA 3.0 FPR2130 Threat Defense Threat, Malware,URL Cisco Systems - Part#: E3S-SFW-FPR2130T Contract Name: New Jersey Cooperative Purchasing Alliance Contract #: CK04 Subcontract #: 24-38 Coverage Term: 4/1/2026 – 3/31/2029 Note: True Forward pricing per unit per year: \$6,164.95	2	\$18,494.83	\$36,989.66
			Total	\$1,241,792.31

Additional Comments

Note: The New Jersey Cooperative Purchasing Alliance is a Service of the County of Bergen, County Executive James J. Tedesco III and the Board of Commissioners

As of February 17, 2025, Cisco no longer requires documented customer acceptance of the EA end user program terms. By submitting a purchase order for this quote, you agree to be bound by the terms found at [Cisco's Enterprise Agreement Terms and Conditions](#). Thank you for choosing SHI International Corp! The pricing offered on this quote proposal is valid through the expiration date listed above. To ensure the best level of service, please provide End User Name, Phone Number, Email Address and applicable Contract Number when submitting a Purchase Order. For any additional information including Hardware, Software and Services Contracts, please contact an SHI Inside Sales Representative at (888) 744-4084. SHI International Corp. is 100% Minority Owned.

Woman Owned Business. TAX ID# 22-3009646; DUNS# 61-1429481; CCR# 61-243957G; CAGE 1HTF0

Please send vouchers to 290 Davidson Ave, Somerset NJ 08873

Due to ongoing global component shortages affecting memory, storage, and other critical PC hardware, quoted prices and lead times may fluctuate. We are committed to keeping you informed of any changes as supply conditions evolve.

Cisco's Terms and Conditions apply to all hardware, software, cloud services, subscriptions, technical support and maintenance included in a Cisco offer.

The products offered under this proposal are resold in accordance with the terms and conditions of the Contract referenced under that applicable line item.

EXHIBIT B

Passaic Valley Water Commission Inter - Office Memorandum

To: L. Bresemann
 From: L. Ducheine
 cc: J. Mueller
 Date: February 27, 2026
 Re: Request permission to renew PVWC CISCO SmartNet Networking License & Support services

The department of information technology request permission to renew the PVWC CISCO SmartNet Networking License & Support services. Cisco SMARTnet is a comprehensive technical support and hardware replacement service. It surpasses general manufacturer's warranties by providing:

- **Hardware Replacement (RMA)** - Rapid and efficient replacement options, with available response times of anything between 2 hours to next business day.
- **Operating System Updates & Security** - Legal access to download major and minor Internet Operating Systems updates and security patches. The service also provides actionable security alerts and threat notification, very helpful to the maintenance of a defensible cybersecurity posture. The alerts and notifications are filtered specifically to the PVWC inventory. This automates the process of identifying devices that are susceptible to a published threat.
- **Technical Assistance Center (TAC) Support** - 24/7 access to expert engineers for troubleshooting network issues that may exceed PVWC's ability to resolve. In such cases, available remote diagnostics help to quickly identify failures and manage complex issues.
- **Lifecycle & Asset Management** - Allows visibility into device installation base, contract coverage and alerts for upgrade path and replacement planning. Important product milestone events like end-of-sale, end-of-support, and end-of-life are tracked automatically. The net result is a reduction in unexpected costs and downtime through proactive lifecycle management.

The impact of this service on performance is documented by International Data Corporation (IDC), a global provider of market intelligence, advisory services and events for IT. Study findings report significant business values that include 253% 3-year return on investment average, 84% lower revenue losses because of increased visibility and network stability; see table below:

Feature	CISCO Standard Warranty	CISCO SMARTnet
Hardware Replacement	Typically, 10 business days	2-4 hour or next business day
Technical Support	None (hardware verification only)	24/7 access to certified Cisco TAC engineers
Software updates	Limited (maintenance releases only)	Full access to OS updates, patches, and major releases
Lifecycle & Diagnostics	No	Installed base insights, automated diagnostics, alert management
Onsite Tech Support	No	Optional onsite technician service available

A good amount of time was invested looking into the benefits of 3 years versus a one-year contract. Our key considerations were affordability through predictable costs as well as alignment with our lifecycle management, because we plan to keep the hardware in production much longer than 3 years. We summarize the pros and cons for both types here:

	Pros	Cons	
1 Year Contract			
Flexibility	- Easier to adjust coverage if hardware changes or upgraded. Ideal for organizations with uncertain future needs or short-term projects.	- Annuals renewals often cost more over time than locking in a multi-year rate. Subject to yearly price increases	Higher Long - Term Cost
Lower upfront cost	- Smaller initial investment compared to multi-year contracts	- It requires yearly renewal processing, adding time and effort.	Administrative Overhead
Technology Alignment	- Optimizes cost avoidance in near term hardware replacement. Minimizes payment for unused coverage.	- Prices may rise each year, making future costs unpredictable.	Budget Uncertainty
3 Years Contract			
Cost Savings	- Multi-year contracts typically offer discounted rates compared to annual renewals. Protects against price increases during the term.	- Larger initial payment, which may strain budgets.	Higher Upfront Cost
Administrative Simplicity	- Fewer renewals to manage, reducing administrative burden.	- Mid-contract upgrades or changes defaults into payments for unused coverage.	Less Flexibility
Budget Predictability	- Fixed cost for three years makes financial planning easier.		

Without launching into the details, *the 3-years plan resonates with our priorities, from a total cost of ownership perspective. Additionally, it is reasonable to expect CISCO to increase SmartNet pricing annually, so a multi-year contract can hedge against inflationary pressures.*

The attached 1-year quote reflects a request for all our device coverages to be co-terminating. The renewal dates will be the same. That is the reason why, in some cases, the start dates are different. The 1-year quote submitted by the vendor is quite lengthy, it is summarized on the next page, for purposes of completeness. Similarly, the 3-years quote will be subsequently summarized:

Service Level	Description	Qty.	Total
ANYSL	- Acts as a single point of contact for an entire "solution" rather than just a single device. Cisco takes the lead in managing the case, even if the issue originates in a third-party product from an Alliance Partner.	100	\$591.80
C4P	- It is a premium hardware maintenance service designed for mission-critical infrastructure that requires high availability	8	\$10,627.68
FTDMI	- Covered device is entitled to receive regular threat intelligence updates and security signature downloads from Cisco's Talos intelligence group.	8	\$52,839.69
L14HR	- Provides 24x7x4 (24 hours a day, 7 days a week, 4-hour response) technical support and hardware replacement.	13	\$40,123.36

L1NBD	-	Next Business Day (NBD) hardware replacement. It is a modern service tier that bundles traditional Smart Net Total Care (SNT) support with enhanced digital capabilities.	107	\$64,758.11
L1SWT	-	Digital-first support tier designed for Cisco DNA Software Subscriptions. It focuses on accelerating technology adoption through the Cisco CX Cloud platform.	2	\$25,256.78
SNT	-	Standard service level for Cisco hardware and operating system software support. It is a device-level contract designed to ensure business continuity through rapid technical assistance and hardware replacement.	20	\$8,441.47
SNTF	-	High-tier SMARTnet service level, though it can also refer to a specific time protocol depending on the context.	93	\$38,174.39
SSTC	-	Smart Net Total Care), which is Cisco's primary technical support service. It is a proactive maintenance package designed to provide rapid hardware replacement, expert technical support, and advanced visibility into your network inventory.	70	\$26,431.90
SUBSCRIPTION	-	Unified licensing and support model that combines software entitlements, hardware management, and technical support into a single recurring contract.	101	\$94,137.69
"	-	"	8	\$4,757.04
"	-	"	90	\$225,601.20
"	-	"	1	\$17,226.00
"	-	"	2	\$48,807.00
			Total =	\$657,774.11

After discussions with the vendor regarding the cost of a 3-year extension of this contract, the vendor agreed to provide a quote that better aligns with PVWC's perspective. Attached is the 3-year contract (*SHI Quote-27168223.pdf*) totaling \$1,241,792.31 for the requested services, ending on 2/28/2029:

- New Jersey Cooperative Alliance
- Contract # CK4
- Subcontract # 24-38

The Information Technology Dept. recommends that the Board approves the licensing renewal. These maintenance items are essential for the proper operation and Licensing of installed hard and software support packages for our infrastructure.

OFFICE OF THE COMPTROLLER

CERTIFICATION OF AVAILABILITY OF FUNDS

It is hereby certified that subject to Commission approval of future Budgets, with respect to multi-budget year contracts, there are or will be sufficient available funds for expenditures to be incurred as a result of any contract or commitment to be entered into by Passaic Valley Water Commission as follows:

Description of Project or Contract: Renewal of "Renewal of Annual Subscriptions for the CISCO SmartNet Networking Licenses" through the New Jersey Cooperative Purchasing Alliance SHI Corporation

Amount of Project or Contract: \$1,241,792.31

1. Acct: # 001-0604-416-70-52
BUDGET – IT Enterprise Software Licensing & Support
2. Specific Appropriation to which expenditures will be charged:
BUDGET 2026/2027/2028

Date of Certification: March 25, 2026

Certified: \$1,241,792.31

Yitzhak Weiss
Comptroller and Chief Financial Officer

YW:lb

RESOLUTION # 26-045

RESOLUTION OF PASSAIC VALLEY WATER COMMISSION

RESOLUTION FOR BUDGET AMENDMENT, CHANGE ORDER NO. 1 AND TIME EXTENSION FOR PROJECT NO. 24-PE-04 ENTITLED "PROFESSIONAL ENGINEERING SERVICE FOR DEVELOPMENT OF A FACILITY PLAN AND BASIS OF DESIGN FOR PFAS TREATMENT AT THE LITTLE FALLS WATER TREATMENT PLANT"

DATE OF ADOPTION: MARCH 25, 2026

Introduced by Commissioner: **RON VAN RENSALIER**

Seconded by Commissioner: **RUBY N. COTTON**

WHEREAS, PVWC awarded Contract No. 24-PE-04 entitled "Professional Engineering Service for Development of a Facility Plan and Basis of Design for PFAS Treatment at the Little Falls Water Treatment Plant" (the "Project") to Black & Veatch Corporation ("B&V") of Overland Park, Kansas at PVWC's Commission Meeting on August 21, 2024 under Resolution No. 24-093 with an expiration date of March 11, 2026 and in an amount not to exceed \$1,999,928.00; and

WHEREAS, the Chief Engineer recommends that PVWC issues Change Order No. 1 to finalize the development of the feasibility study and conceptual design for PFAS treatment and pumping and continue to oversee the piloting efforts conducted by Cornwell Engineering to ensure compliance with the NJDEP's requirements with an additional increase of \$152,093.00 which brings the total adjusted Contract Price up to \$2,152,021.00 and a time extension for the Project thereby setting a new expiration date of December 31, 2026; and

WHEREAS, PVWC's Chief Financial Officer has certified, with respect hereto, that funds are currently available for said purpose and a copy of the said certification is attached hereto and made a part hereof as **Exhibit A**.

NOW, THEREFORE, BE IT RESOLVED, by Passaic Valley Water Commission, in the County of Passaic, New Jersey:

1. That PVWC hereby authorizes Change Order No. 1 and contract extension to the terms as set forth hereinabove; and
2. That appropriate officers of the Commission are hereby authorized and directed to execute this Contract extension as set forth hereinabove and implement the terms of this extended Contract in accordance with this Resolution and the submissions provided in connection herewith, and the Secretary of PVWC to attest to this Contract extension and such other officers, employees and officials of PVWC are hereby authorized to perform such acts and execute such documents as are necessary to implement the terms and intentions of this Resolution; and
3. That this matter shall be advertised as required by New Jersey law, in accordance with an appropriate form of notice, and a copy of this Resolution shall be placed on file and made available for public inspection at the office of the Administrative Secretary of Passaic Valley Water Commission.

RECORD OF COMMISSION VOTE ON FINAL PASSAGE

	AYE	NAY	ABSTAIN	ABSENT
COTTON, R.	<u>X</u>	—	—	—
DEPADUA, C.	<u>X</u>	—	—	—
FRIEND, G.	<u>X</u>	—	—	—
LEVINE, J.	<u>X</u>	—	—	—
SANCHEZ, R.	<u>X</u>	—	—	—
VAN RENSA LIER, R.	<u>X</u>	—	—	—
RIZZI, D.	<u>X</u>	—	—	—

Adopted at a meeting of Passaic Valley Water Commission.



DEBORAH RIZZI
 President



RUBY N. COTTON
 Secretary

This Resolution, when adopted, must remain in the custody of the Administrative Secretary.

CERTIFICATION

I, LOUIS AMODIO, Administrative Secretary of the Passaic Valley Water Commission in the County of Passaic, and the State of New Jersey do hereby certify that the foregoing Resolution is a true copy thereof of the foregoing Resolution duly passed and adopted by a majority of a legal quorum of the full membership of the Passaic Valley Water Commission at its duly noticed and convened meeting of the said Commission on March 25, 2026.

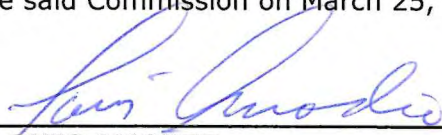

LOUIS AMODIO
 Administrative Secretary

EXHIBIT A

OFFICE OF THE COMPTROLLER

CERTIFICATION OF AVAILABILITY OF FUNDS

It is hereby certified that subject to Commission approval of future Budgets, with respect to multi-budget year contracts, there are or will be sufficient available funds for expenditures to be incurred as a result of any contract or commitment to be entered into by Passaic Valley Water Commission as follows:

Description of Project or Contract: Contract No.: 24-PE-04 – Change Order No. 1
“Professional Engineering Service for Development
of a Facility Plan and Basis of Design for PFAS
Treatment at the Little Falls Water Treatment Plant”
Black & Veatch Corp.

Amount of Project or Contract:

Change Order No. 1 Increase of \$152,093.00
Change Order No. 1 Not to Exceed: \$2,152,021.00

1. Acct: # 001-0901-419-95-14
CAPITAL/PFAS
2. Specific Appropriation to which expenditures will be charged:
CAPITAL: 2026

Other comments: Change Order No. 1 – Increase of \$152,093.00
For a new Not to Exceed of \$2,152,021.00

Date of Certification: March 25, 2026 Amount Certified: \$2,152,021.00

Yitzhak Weiss
Comptroller and Chief Financial Officer

YW:lb

RESOLUTION NO. 26-046

PASSAIC VALLEY WATER COMMISSION

RESOLUTION AWARDING PROJECT 26-PE-08 ENTITLED "PROFESSIONAL ENGINEERING SERVICES FOR IMPLEMENTING A WATER MAIN REPLACEMENT PROGRAM FOR CLIFTON"

DATE OF ADOPTION: MARCH 25, 2026

Introduced by Commissioner: **RON VAN RENSA LIER**

Seconded by Commissioner: **RUBY N. COTTON**

WHEREAS, Passaic Valley Water Commission ("PVWC") has solicited for Extraordinary Unspecifiable Services ("EUSs") for Contract No. 26-PE-08 entitled "Professional Engineering Services for Implementing a Water Main Replacement Program for Clifton" (hereinafter the "Project"); and

WHEREAS, said Contract shall be awarded as an EUS under the Non-Fair and Open Process and N.J.S.A. 40A:11-5(1)(a)(i) for completing the design of the Piaget Avenue and Paulison Avenue water main replacement projects for Clifton and provide design support services during construction; and

WHEREAS, said Contract is the continuation of on-going work required to complete said projects; and

WHEREAS, the firm of HDR Engineering, Inc. of Mahwah, New Jersey (the "Awardee") was determined to be professionally qualified and capable of performing the required services with respect to the Project, with reimbursement to be on a Take-and-Pay, Time-and-Materials basis, not to exceed \$625,000 until December 31, 2027, as stipulated by the Commission in the Form of Agreement for Professional Services (the "Contract"); and

WHEREAS, it is in the best interest of PVWC, its users and constituent municipalities to engage, or continue to engage, the services of the Awardee at this time; and

WHEREAS, PVWC's Chief Financial Officer has certified, with respect hereto, that funds are currently available for said purpose and a copy of the said certification is attached hereto and made a part hereof as **Exhibit A**.

NOW, THEREFORE, BE IT RESOLVED, by Passaic Valley Water Commission, in the County of Passaic, New Jersey:

1. That PVWC hereby awards the Contract to the Awardee in accordance with N.J.S.A. 40A:11-5(1)(a)(i) and N.J.S.A. 19:44A-1 et seq. as set forth hereinabove; and
2. That an appropriate official of PVWC, on behalf of PVWC, is hereby authorized and directed to execute the Contract hereby awarded to the Awardee and the Secretary of PVWC to attest to the Contract and such other officers, employees and officials of PVWC are hereby authorized to perform such acts and execute such documents as are necessary to implement the terms and intentions of this Resolution; and
3. That this matter shall be advertised as required by New Jersey law, in accordance with an appropriate form of notice, and a copy of this Resolution and Agreement shall be placed on file and made available for inspection at the office of the Administrative Secretary of Passaic Valley Water Commission.

RECORD OF COMMISSION VOTE ON FINAL PASSAGE

	AYE	NAY	ABSTAIN	ABSENT
COTTON, R.	<u>X</u>	---	---	---
DEPADUA, C.	<u>X</u>	---	---	---
FRIEND, G.	<u>X</u>	---	---	---
LEVINE, J.	<u>X</u>	---	---	---
SANCHEZ, R.	<u>X</u>	---	---	---
VAN RENSA LIER, R.	<u>X</u>	---	---	---
RIZZI, D.	<u>X</u>	---	---	---

Adopted at a meeting of Passaic Valley Water Commission.

DEBORAH RIZZI
 President

RUBY N. COTTON
 Secretary

This Resolution, when adopted, must remain in the custody of the Administrative Secretary.

CERTIFICATION

I, LOUIS AMODIO, Administrative Secretary of the Passaic Valley Water Commission in the County of Passaic, and the State of New Jersey do hereby certify that the foregoing Resolution is a true copy thereof of the foregoing Resolution duly passed and adopted by a majority of a legal quorum of the full membership of the Passaic Valley Water Commission at its duly noticed and convened meeting of the said Commission on March 25, 2026.



LOUIS AMODIO
 Administrative Secretary

EXHIBIT A

RESOLUTION NO. 26-047

PASSAIC VALLEY WATER COMMISSION

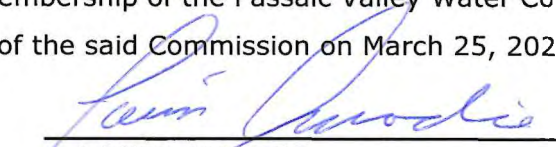
**RESOLUTION AWARDING PROJECT 26-PE-09 ENTITLED "PROFESSIONAL
ENGINEERING SERVICES FOR IMPLEMENTING A WATER MAIN REPLACEMENT
PROGRAM FOR PASSAIC"**

DATE OF ADOPTION: MARCH 25, 2026

Introduced by Commissioner: **RON VAN RENSA LIER**

Seconded by Commissioner: **RUBY N. COTTON**

WHEREAS, Passaic Valley Water Commission ("PVWC") has solicited for Extraordinary Unspecifiable Services ("EUSs") for Contract No. 26-PE-09 entitled "Professional Engineering Services for Implementing a Water Main Replacement Program for Passaic" (hereinafter the "Project"); and

WHEREAS, said Contract shall be awarded as an EUS under the Non-Fair and Open Process and N.J.S.A. 40A:11-5(1)(a)(i) for completing the design of the Clifton Boulevard, Harrison Avenue and Sherman Street water main replacement projects for Passaic and provide design support services during construction; and

WHEREAS, said Contract is the continuation of on-going work required to complete said projects; and

WHEREAS, the firm of HDR Engineering, Inc. of Mahwah, New Jersey (the "Awardee") was determined to be professionally qualified and capable of performing the required services with respect to the Project, with reimbursement to be on a Take-and-Pay, Time-and-Materials basis, not to exceed \$325,000 until December 31, 2027, as stipulated by the Commission in the Form of Agreement for Professional Services (the "Contract"); and

WHEREAS, it is in the best interest of PVWC, its users and constituent municipalities to engage, or continue to engage, the services of the Awardee at this time; and

WHEREAS, PVWC's Chief Financial Officer has certified, with respect hereto, that funds are currently available for said purpose and a copy of the said certification is attached hereto and made a part hereof as **Exhibit A**.

NOW, THEREFORE, BE IT RESOLVED, by Passaic Valley Water Commission, in the County of Passaic, New Jersey:

1. That PVWC hereby awards the Contract to the Awardee in accordance with N.J.S.A. 40A:11-5(1)(a)(i) and N.J.S.A. 19:44A-1 et seq. as set forth hereinabove; and
2. That an appropriate official of PVWC, on behalf of PVWC, is hereby authorized and directed to execute the Contract hereby awarded to the Awardee and the Secretary of PVWC to attest to the Contract and such other officers, employees and officials of PVWC are hereby authorized to perform such acts and execute such documents as are necessary to implement the terms and intentions of this Resolution; and
3. That this matter shall be advertised as required by New Jersey law, in accordance with an appropriate form of notice, and a copy of this Resolution and Agreement shall be placed on file and made available for inspection at the office of the Administrative Secretary of Passaic Valley Water Commission.

RECORD OF COMMISSION VOTE ON FINAL PASSAGE

	AYE	NAY	ABSTAIN	ABSENT
COTTON, R.	<u>X</u>	---	---	---
DEPADUA, C.	<u>X</u>	---	---	---
FRIEND, G.	<u>X</u>	---	---	---
LEVINE, J.	<u>X</u>	---	---	---
SANCHEZ, R.	<u>X</u>	---	---	---
VAN RENSALIER, R.	<u>X</u>	---	---	---
RIZZI, D.	<u>X</u>	---	---	---

Adopted at a meeting of Passaic Valley Water Commission.

DEBORAH RIZZI
 President

RUBY N. COTTON
 Secretary

This Resolution, when adopted, must remain in the custody of the Administrative Secretary.

CERTIFICATION

I, LOUIS AMODIO, Administrative Secretary of the Passaic Valley Water Commission in the County of Passaic, and the State of New Jersey do hereby certify that the foregoing Resolution is a true copy thereof of the foregoing Resolution duly passed and adopted by a majority of a legal quorum of the full membership of the Passaic Valley Water Commission at its duly noticed and convened meeting of the said Commission on March 25, 2026.



LOUIS AMODIO
 Administrative Secretary

EXHIBIT A

RESOLUTION NO. 26-048

PASSAIC VALLEY WATER COMMISSION

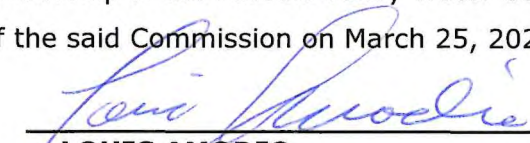
RESOLUTION AWARDING PROJECT 26-PE-10 ENTITLED "PROFESSIONAL ENGINEERING SERVICES FOR IMPLEMENTING A WATER MAIN REPLACEMENT PROGRAM FOR PATERSON AND PROSPECT PARK"

DATE OF ADOPTION: MARCH 25, 2026

Introduced by Commissioner: **RON VAN RENSA LIER**

Seconded by Commissioner: **RUBY N. COTTON**

WHEREAS, Passaic Valley Water Commission ("PVWC") has solicited for Extraordinary Unspecifiable Services ("EUSs") for Contract No. 26-PE-10 entitled "Professional Engineering Services for Implementing a Water Main Replacement Program for Paterson and Prospect Park" (hereinafter the "Project"); and

WHEREAS, said Contract shall be awarded as an EUS under the Non-Fair and Open Process and N.J.S.A. 40A:11-5(1)(a)(i) for completing the design of Phase 1 and 2 of the Garrett Heights Service Area, Great Falls and Granite Ave Service Area water main replacement projects for Paterson and provide design support services during construction; and

WHEREAS, said Contract is the continuation of on-going work required to complete said projects; and

WHEREAS, the firm of GFT Infrastructure, Inc. of Newark, New Jersey (the "Awardee") was determined to be professionally qualified and capable of performing the required services with respect to the Project, with reimbursement to be on a Take-and-Pay, Time-and-Materials basis, not to exceed \$750,000 until December 31, 2029, as stipulated by the Commission in the Form of Agreement for Professional Services (the "Contract"); and

WHEREAS, it is in the best interest of PVWC, its users and constituent municipalities to engage, or continue to engage, the services of the Awardee at this time; and

WHEREAS, PVWC's Chief Financial Officer has certified, with respect hereto, that funds are currently available for said purpose and a copy of the said certification is attached hereto and made a part hereof as **Exhibit A**.

NOW, THEREFORE, BE IT RESOLVED, by Passaic Valley Water Commission, in the County of Passaic, New Jersey:

1. That PVWC hereby awards the Contract to the Awardee in accordance with N.J.S.A. 40A:11-5(1)(a)(i) and N.J.S.A. 19:44A-1 et seq. as set forth hereinabove; and
2. That an appropriate official of PVWC, on behalf of PVWC, is hereby authorized and directed to execute the Contract hereby awarded to the Awardee and the Secretary of PVWC to attest to the Contract and such other officers, employees and officials of PVWC are hereby authorized to perform such acts and execute such documents as are necessary to implement the terms and intentions of this Resolution; and
3. That this matter shall be advertised as required by New Jersey law, in accordance with an appropriate form of notice, and a copy of this Resolution and Agreement shall be placed on file and made available for inspection at the office of the Administrative Secretary of Passaic Valley Water Commission.

RECORD OF COMMISSION VOTE ON FINAL PASSAGE

	AYE	NAY	ABSTAIN	ABSENT
COTTON, R.	<u>X</u>	—	—	—
DEPADUA, C.	<u>X</u>	—	—	—
FRIEND, G.	<u>X</u>	—	—	—
LEVINE, J.	<u>X</u>	—	—	—
SANCHEZ, R.	<u>X</u>	—	—	—
VAN RENSA LIER, R.	<u>X</u>	—	—	—
RIZZI, D.	<u>X</u>	—	—	—

Adopted at a meeting of Passaic Valley Water Commission.



DEBORAH RIZZI
 President



RUBY N. COTTON
 Secretary

This Resolution, when adopted, must remain in the custody of the Administrative Secretary.

CERTIFICATION

I, LOUIS AMODIO, Administrative Secretary of the Passaic Valley Water Commission in the County of Passaic, and the State of New Jersey do hereby certify that the foregoing Resolution is a true copy thereof of the foregoing Resolution duly passed and adopted by a majority of a legal quorum of the full membership of the Passaic Valley Water Commission at its duly noticed and convened meeting of the said Commission on March 25, 2026.

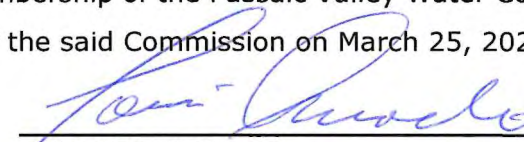

LOUIS AMODIO
 Administrative Secretary

EXHIBIT A

OFFICE OF THE COMPTROLLER

CERTIFICATION OF AVAILABILITY OF FUNDS

It is hereby certified that subject to Commission approval of future Budgets, with respect to multi-budget year contracts, there are or will be sufficient available funds for expenditures to be incurred as result of any contract or commitment to be entered into by Passaic Valley Water Commission as follows:

Description of Project or Contract: Project 26-PE-10
 "Professional Engineering Services for
 Implementing a Water Main Replacement
 Program for Paterson and Prospect Park"
 GFT

Project No. 26-PE-10
Not to Exceed \$750,000.00

1. Acct: # 001-0901-419-95-14
 CAPITAL/WATER MAIN IMPROVEMENTS

2. Specific Appropriation to which expenditures will be charged:
 CAPITAL: 2026, 2027, 2028, 2029

Other comments: Professional Services – 45 Months

Date of Certification: March 25, 2026 Certified: \$750,000.00

Yitzhak Weiss
Comptroller and Chief Financial Officer

YW:lb

RESOLUTION NO. 26-049

PASSAIC VALLEY WATER COMMISSION

**RESOLUTION FOR BUDGET AMENDMENT, CHANGE ORDER NO. 1
FOR PVWC UNIFORM CONTRACT WITH CINTAS**

DATE OF ADOPTION: MARCH 25, 2026

Introduced by Commissioner: **RON VAN RENSALIER**

Seconded by Commissioner: **RUBY N. COTTON**

WHEREAS, on June 28, 2023, PVWC awarded a three-year contract to Cintas for the rental of uniforms utilizing a cooperative purchase alliance; and

WHEREAS, Proposed Change Order No. 1 is required to pay for additional services necessitated by the increase in rental uniforms that occurred when PVWC hired additional staff who required uniforms. The additional costs have been determined to be \$27,306.80, bringing the new contract price to \$507,598.16.

WHEREAS, PVWC's Chief Financial Officer has certified, with respect hereto, that funds are currently available for said purpose and a copy of the said certification is attached hereto and made a part hereof as **Exhibit A**.

NOW, THEREFORE, BE IT RESOLVED, by Passaic Valley Water Commission, in the County of Passaic, New Jersey:

1. That PVWC hereby authorizes and awards Change Order No. 1 to the terms as set forth hereinabove; and
2. That an appropriate official of PVWC, on behalf of PVWC, is hereby authorized and directed to execute this Change Order as set forth hereinabove and implement the terms of this Change Order in accordance with this Resolution and the submissions provided in connection herewith, and the Secretary of PVWC to attest to this Change Order No. 1 and such other officers, employees and officials of PVWC are hereby authorized to perform such acts and

execute such documents as are necessary to implement the terms and intentions of this Resolution; and

3. That this matter shall be advertised as required by New Jersey law, in accordance with an appropriate form of notice, and a copy of this Resolution shall be placed on file and made available for public inspection at the office of the Administrative Secretary of Passaic Valley Water Commission.

RECORD OF COMMISSION VOTE ON FINAL PASSAGE

	AYE	NAY	ABSTAIN	ABSENT
COTTON, R.	<u>X</u>	___	___	___
DEPADUA, C.	<u>X</u>	___	___	___
FRIEND, G.	<u>X</u>	___	___	___
LEVINE, J.	<u>X</u>	___	___	___
SANCHEZ, R.	<u>X</u>	___	___	___
VAN RENSA LIER, R.	<u>X</u>	___	___	___
RIZZI, D.	<u>X</u>	___	___	___

Adopted at a meeting of Passaic Valley Water Commission.



DEBORAH RIZZI
President



RUBY N. COTTON
Secretary

This Resolution, when adopted, must remain in the custody of the Administrative Secretary.

CERTIFICATION

I, LOUIS AMODIO, Administrative Secretary of the Passaic Valley Water Commission in the County of Passaic, and the State of New Jersey do hereby certify that the foregoing Resolution is a true copy thereof of the foregoing Resolution duly passed and adopted by a majority of a legal quorum of the full membership of the Passaic Valley Water Commission at its duly noticed and convened meeting of the said Commission on March 25, 2026.

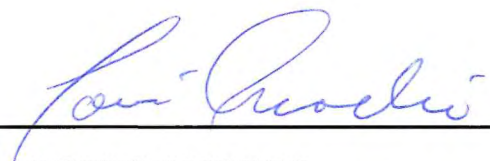

LOUIS AMODIO
Administrative Secretary

EXHIBIT A

OFFICE OF THE COMPTROLLER

CERTIFICATION OF AVAILABILITY OF FUNDS

It is hereby certified that subject to Commission approval of future Budgets, with respect to multi-budget year contracts, there are or will be sufficient available funds for expenditures to be incurred as a result of any contract or commitment to be entered into by Passaic Valley Water Commission as follows:

Description of Project or Contract: Resolution to “Approve Change Order No. 1 for Cintas Uniform Contract”
Cintas

Amount of Project or Contract:

Change Order No. 1 Increase of \$27,306.80
Change Order No. 1 Not to Exceed: \$507,598.16

1. Acct: #- 001-0901-419-70-22
BUDGET – SERVICES/UNIFORMS
2. Specific Appropriation to which expenditures will be charged:
BUDGET 2026

Other Comments: Change Order No. 1 – Increase of \$27,306.80
For a new Not to Exceed of \$507,598.16

Date of Certification: March 25, 2026

Certified: \$507,598.16

Yitzhak Weiss
Comptroller and Chief Financial Officer

YW:lb

RESOLUTION # 26-050

RESOLUTION OF PASSAIC VALLEY WATER COMMISSION

RESOLUTION APPROVING CHANGE ORDER NO. 1 FOR PROJECT NO. 25-PA-08 ENTITLED "PROFESSIONAL SERVICES FOR IMPLEMENTATION OF ORACLE FINANCIAL MANAGEMENT SYSTEM"

DATE OF ADOPTION: MARCH 25, 2026

Introduced by Commissioner: **RON VAN RENSA LIER**

Seconded by Commissioner: **RUBY N. COTTON**

WHEREAS, PVWC awarded Contract No. 25-PA-08 entitled "Professional Services for Implementation of Oracle Financial Management System" (the "Project") to CGI Technologies and Solutions ("CGI") of Fairfax, Virginia at PVWC's Commission Meeting on May 21, 2025 under Resolution No. 25-090 all in accordance with N.J.S.A. 40A:11-5(1)(a)(i); and in an amount not to exceed \$405,000.00; and

WHEREAS, it is recommended that PVWC issues Change Order No. 1 to fund the additional efforts required for the implementation of the Oracle Financial Management System, known as NetSuite. It has been anticipated that we will require an additional five (5) months of service. The memorandum dated February 27, 2026, composed by Yitzchak Weiss, CFO describing the need for the extra months of services is attached hereto as **Exhibit A.**

WHEREAS, the monthly cost of these services is \$45,000.00 per month and the total requested in Change Order No. 1 is \$225,000.00 for a new not to exceed of \$630,000.00. The proposed agreement is attached hereto as **Exhibit B;** and

WHEREAS, PVWC's Chief Financial Officer has certified, with respect hereto, that funds are currently available for said purpose and a copy of the said certification is attached hereto and made a part hereof as **Exhibit C.**

NOW, THEREFORE, BE IT RESOLVED, by Passaic Valley Water Commission, in the County of Passaic, New Jersey:

1. That PVWC hereby authorizes Change Order No. 1 to the terms as set forth hereinabove; and
2. That appropriate officers of the Commission are hereby authorized and directed to execute this Contract Change Order as set forth hereinabove and implement the terms of this extended Contract in accordance with this Resolution and the submissions provided in connection herewith, and the Secretary of PVWC to attest to this Contract extension and such other officers, employees and officials of PVWC are hereby authorized to perform such acts and execute such documents as are necessary to implement the terms and intentions of this Resolution; and
3. That this matter shall be advertised as required by New Jersey law, in accordance with an appropriate form of notice, and a copy of this Resolution shall be placed on file and made available for public inspection at the office of the Administrative Secretary of Passaic Valley Water Commission.

RECORD OF COMMISSION VOTE ON FINAL PASSAGE

	AYE	NAY	ABSTAIN	ABSENT
COTTON, R.	<u>X</u>	—	—	—
DEPADUA, C.	<u>X</u>	—	—	—
FRIEND, G.	<u>X</u>	—	—	—
LEVINE, J.	<u>X</u>	—	—	—
SANCHEZ, R.	<u>X</u>	—	—	—
VAN RENSALIER, R.	<u>X</u>	—	—	—
RIZZI, D.	<u>X</u>	—	—	—

Adopted at a meeting of Passaic Valley Water Commission.



DEBORAH RIZZI
President



RUBY N. COTTON
Secretary

This Resolution, when adopted, must remain in the custody of the Administrative Secretary.

CERTIFICATION

I, LOUIS AMODIO, Administrative Secretary of the Passaic Valley Water Commission in the County of Passaic, and the State of New Jersey do hereby certify that the foregoing Resolution is a true copy thereof of the foregoing Resolution duly passed and adopted by a majority of a legal quorum of the full membership of the Passaic Valley Water Commission at its duly noticed and convened meeting of the said Commission on March 25, 2026.

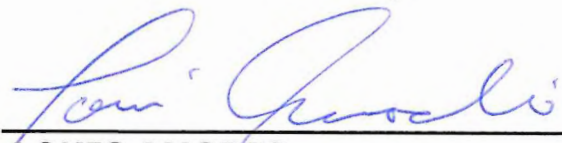

LOUIS AMODIO
Administrative Secretary

EXHIBIT A

Passaic Valley Water Commission

Inter-office Memo

To: Lisa Bresemann, QPA

Date: February 27, 2026

From: Yitzchak Weiss, CFO

Re: Request to Extend CGI Oracle Implementation Support

As the Board is aware, PVWC is currently in the final stages of implementing the Oracle NetSuite Financial Management System. The system is scheduled to go live in July of this year.

CGI has been providing independent quality assurance and technical advisory support throughout the implementation process. Their role has been to review Oracle's deliverables, validate testing and configuration, and provide objective oversight to ensure the system is implemented in accordance with contract expectations and PVWC's operational needs.

CGI's current contract expires on April 30, 2026. In order to maintain continuity of oversight through go-live and post-implementation stabilization, I am recommending an extension of their agreement through September 30, 2026.

Respectfully submitted,

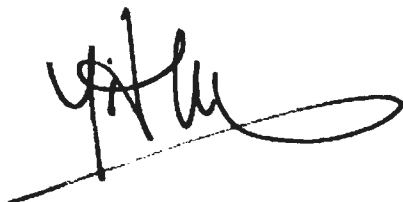
A handwritten signature in black ink, appearing to read 'Yitzchak Weiss', with a long horizontal flourish extending to the right.

Yitzchak Weiss, CPA
Chief Financial Officer

cc: Jim Mueller, Executive Director
Lisa Bresemann, Purchasing Director

EXHIBIT B



**Purchase Order #: 235251
Oracle Financial Management System Support
CHANGE REQUEST #1**

This Change Request #1 ("Change Request" or "CR") dated as of the last date signed below ("Effective Date") is entered into by and between the Passaic Valley Water Commission (the "PVWC" or "Client") and CGI Technologies and Solutions Inc. ("PROFESSIONAL" or "CGI"). This Change Request is issued pursuant to the Passaic Valley Water Commission Purchase Order #: 235251 and its appendices by and between PVWC and CGI executed on or about June 11, 2025 (the "Agreement"). Capitalized terms not otherwise defined in this Change Request will have the same meaning as in the Agreement.

1. CHANGES

Change Request Information													
Document Reference(s)	Purchase Order Form / Cover Page												
Section Reference(s)	The 'Description' column												
Description of Change(s)	Update the following: <ul style="list-style-type: none"> • EXPIRATION DATE to 8/31/2026 • NOT TO EXCEED to \$225,000 												
Changes in Pricing/Fees?	YES <input checked="" type="checkbox"/> NO <input type="checkbox"/>												
	Change Request Amounts (if any): <ul style="list-style-type: none"> • The monthly compensation remains as a fixed monthly fee of \$45,000 per month as follows: 												
	<table border="1"> <thead> <tr> <th>Month</th> <th>Amount</th> </tr> </thead> <tbody> <tr> <td>May 2026</td> <td>\$45,000</td> </tr> <tr> <td>June 2026</td> <td>\$45,000</td> </tr> <tr> <td>July 2026</td> <td>\$45,000</td> </tr> <tr> <td>August 2026* (OPTIONAL)</td> <td>\$45,000*</td> </tr> <tr> <td>September 2026* (OPTIONAL)</td> <td>\$45,000*</td> </tr> </tbody> </table>	Month	Amount	May 2026	\$45,000	June 2026	\$45,000	July 2026	\$45,000	August 2026* (OPTIONAL)	\$45,000*	September 2026* (OPTIONAL)	\$45,000*
	Month	Amount											
	May 2026	\$45,000											
June 2026	\$45,000												
July 2026	\$45,000												
August 2026* (OPTIONAL)	\$45,000*												
September 2026* (OPTIONAL)	\$45,000*												
<p><i>*Note: The month of August & September 2026 is OPTIONAL. If Oracle NetSuite go-live occurs before August 1, 2026, CGI and PVWC will stop work and no invoice will be submitted for either optional month in 2026. If work continues past August 1, 2026, CGI will only invoice a daily rate of \$2,143 per business day through the month of August & September up to a maximum of \$45,000.</i></p>													
Reason for Change(s)	Oracle NetSuite go-live is planned for a July 31, 2026 and the current contract end date is 4/30/2026. An extension is required for CGI to continue to supporting this project.												



Change Request agreed to and accepted by:

Passaic Valley Water Commission
(PVWC)

CGI Technologies and Solutions Inc.
(CGI)

Signature: _____

Signature: _____

Name: _____

Name: _____

Title: _____

Title: _____

Date: _____

Date: _____

EXHIBIT C

OFFICE OF THE COMPTROLLER

CERTIFICATION OF AVAILABILITY OF FUNDS

It is hereby certified that subject to Commission approval of future Budgets, with respect to multi-budget year contracts, there are or will be sufficient available funds for expenditures to be incurred as a result of any contract or commitment to be entered into by Passaic Valley Water Commission as follows:

Description of Project or Contract: Project No.: 25-PA-08
"Professional Services for Implementation of Oracle
Financial Management System"
CGI Technologies and Solutions, Inc.

Amount of Project or Contract:

Change Order No. 1 Increase of \$225,000.00 (5 Months at \$45,000.00. Per Month)
Change Order No. 1 Not to Exceed: \$630,000.00

1. Acct: #- 001-0901-419-95-07
CAPITAL – COMPUTERS & SOFTWARE
2. Specific Appropriation to which expenditures will be charged:
CAPITAL 2026

Other Comments: Change Order No. 1 – Increase of \$225,000.00
For a new Not to Exceed of \$630,000.00

Date of Certification: March 25, 2026

Certified: \$630,000.00

Yitzchak Weiss
Comptroller and Chief Financial Officer

YW:lb

RESOLUTION NO. 26-051

PASSAIC VALLEY WATER COMMISSION

**RESOLUTION AUTHORIZING THE REPLACEMENT OF TWO PUMPS FOR
THE MORRIS COUNTY PUMP STATION UTILIZING THE
PVSC PURCHASING COOPERATIVE, CONTRACT #B369-14**

DATE OF ADOPTION: MARCH 25, 2026

Introduced by Commissioner: **RON VAN RENSALIER**

Seconded by Commissioner: **RUBY N. COTTON**

WHEREAS, Pumping Operations has determined that they are in need of two new pumps for the Morris County Pump Station to support continuous and reliable water distribution; and

WHEREAS, Chief Operating Officer Michael Marotta prepared a Memorandum dated March 5, 2026 (the "Memorandum") describing the immediate need for replacement of the one inoperable pump as well as a dedicated spare, that are essential for uninterrupted service; (See **Exhibit A**); and

WHEREAS, PVWC has elected to replace the above-referenced pumps from Precision Electric Motor Works, Inc. of Clifton, New Jersey (the "Awardee") under the Cooperative, with the cost of each pump being \$153,326.25 for a total of \$306,652.50; a copy of the quotation number SQ27664 is attached hereto as **Exhibit B**; and

WHEREAS, the Passaic Valley Sewerage Commission Purchasing Cooperative, Contract B369-14 (the "Co-op") shall be used for the procurement of the Two Simflo NSF 61 Certified Vertical Turbine Lineshaft Pump Model SM20M-4 Stage; and

WHEREAS, in accordance with N.J.S.A. 40A:11-12, PVWC may purchase goods or services under contracts entered into on behalf of the State by the Division of Purchase and Property in the Department of the Treasury; and

WHEREAS, PVWC's Chief Financial Officer has certified, with respect hereto, that funds are currently available for said purpose and a copy of the said certification is attached hereto and made a part hereof as **Exhibit C**;

NOW, THEREFORE, BE IT RESOLVED, by Passaic Valley Water Commission, in the County of Passaic, New Jersey;

1. That the Cooperative Pricing Agreement for replacement of the above-referenced Morris County Pumps is hereby awarded to the Awardee as set forth hereinabove; and
2. That the appropriate officers and employees of PVWC are hereby authorized and directed to perform such acts and execute such documents as are consistent herewith, with respect to the Cooperative Pricing Agreement as set forth hereinabove.

RECORD OF COMMISSION VOTE ON FINAL PASSAGE

	AYE	NAY	ABSTAIN	ABSENT
COTTON, R.	<u>X</u>	___	___	___
DEPADUA, C.	<u>X</u>	___	___	___
FRIEND, G.	<u>X</u>	___	___	___
LEVINE, J.	<u>X</u>	___	___	___
SANCHEZ, R.	<u>X</u>	___	___	___
VAN RENSALIER, R.	<u>X</u>	___	___	___
RIZZI, D.	<u>X</u>	___	___	___

Adopted at a meeting of Passaic Valley Water Commission.



DEBORAH RIZZI
President



RUBY N. COTTON
Secretary

This Resolution, when adopted, must remain in the custody of the Administrative Secretary.

CERTIFICATION

I, LOUIS AMODIO, Administrative Secretary of the Passaic Valley Water Commission in the County of Passaic, and the State of New Jersey do hereby certify that the foregoing Resolution is a true copy thereof of the foregoing Resolution duly passed and adopted by a majority of a legal quorum of the full membership of the Passaic Valley Water Commission at its duly noticed and convened meeting of the said Commission on March 25, 2026.

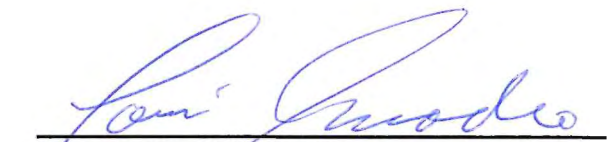

LOUIS AMODIO
Administrative Secretary

EXHIBIT A



Executive Director
James Mueller, PE

Commissioners
Deborah Rizzi, President, Clifton
Carmen DePadua, Vice President, Paterson
Ronald Van Rensalier, Treasurer, Passaic
Ruby N. Cotton, Secretary, Paterson
Gerald Friend, Commissioner, Clifton
Jeffrey Levine, Commissioner, Paterson
Rigo Sanchez, Commissioner, Passaic

MEMORANDUM

To: Lisa Bresemann
From: Mike Marotta
Date: March 5, 2026
Subject: Purchase of Two Morris County Pumps/PVSC Purchasing Cooperative Contract # B369-14

I am requesting approval to purchase two new Morris County pumps to support continuous and reliable water distribution. These pumps will allow us to rotate our three existing pumps for maintenance one at a time while maintaining a dedicated spare, which is essential for uninterrupted service.

We have identified an opportunity to switch to pumps with the same specifications from a different supplier. This option provides significant cost savings and a much shorter lead time, as shown below.

Cost & Lead Time Comparison

Item	Original Pump	Alternate Pump
Estimated Cost per Pump	\$410,000.00 per pump	\$153,000 per pump
Estimated Lead Time	44 weeks	16-18 weeks

Total Cost for 2 New Pumps is \$306,652.00

Second Quote is \$469,400.00

The reduced lead time will allow for quicker deployment and improved operational readiness, while the cost savings will significantly lower project expenses.

Thank you,

Michael Marotta
Chief Operating Officer

PASSAIC VALLEY WATER COMMISSION
1525 MAIN AVENUE • P.O. BOX 230
CLIFTON, NEW JERSEY 07011
(973) 340-4300

EXHIBIT B



AN **IPS** COMPANY
 18 SEBAGO ST., CLIFTON, NJ 07011
 TEL: (973) 471-2600 FAX: (973) 471-4633

Morris County Pumps **Quote**

Contact: _____
 Customer Number: **PASSAIC WATER C**
 Quote Date: **1/22/2026**
 Quote Number: **SC27664**

Quote To:
 Passaic Valley Water Commission
 1525 Main Avenue
 P.O. Box 230
 Clifton, NJ 07011

Ship To:
 Passaic Valley Water Commission
 1525 Main Avenue
 P.O. Box 230
 Clifton, NJ 07011

Ship Via: _____ Terms: **Net 30** Quoted By: **Alex Zelenka** Customer RFG: _____ Customer PO: _____

Product ID	Qty	Description	Sales Price	Total
SM20M-4	1	Similo NSF 81 Certified Vertical Turbine Lineshaft Pump Model SM20M-4 Stage 1800 RPM, 20' Fabricated Milled Steel Above Ground Discharge Head to mount on existing 42" Can. Open Lineshaft with Product lubrication and Packing. Cast Iron Construction with Ni-Aluminum Bronze Impellers 20' Ranged column 418 Heat Treated Stainless Steel lineshaft-2-11/16" Diameter. Driven by existing 1000HP 1800RPM Vertical Solid Shaft High Thrust Motor. Designed to Pump 5787GPM@555' TDH-Pump Total Pump Length-279". Includes Coasting-Tranmec Series 21 Epoxy-10-20 mils DFT, Black, Bowl Assembly OD, Column ID and OD, and Discharge Head ID and OD. Headsheet Coupling Included Two(2) Days Start-up Assistance and Field Testing	153,326.25	153,326.25

<i>Sales Tax and Freight are not included in total, unless noted otherwise. Quote is valid for <30> Days.</i>		Availability-16-18 weeks	Subtotal:	153,326.25
<i>Terms and conditions: https://www.ips.us/terms-and-conditions-usa/</i>		FOB-Lubbock, TX	Freight:	0.00
			Other:	0.00
		0.0000 %	Sales Tax 1:	0.00
		0.0000 %	Sales Tax 2:	0.00
			Total:	153,326.25

Thank You

SIGNATURE: _____ DATE: _____
 PO# (IF NOT ALREADY ISSUED): _____

X2
\$306,652.50

Overall Drawing
With SL Miter Discharge Head,
Flanged Column

-Date: 2025-11-04
-Quote / Order # : 25201

-Job Name / Description: Pasaic
Valley Replacement

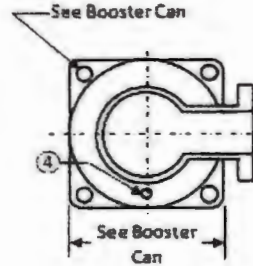
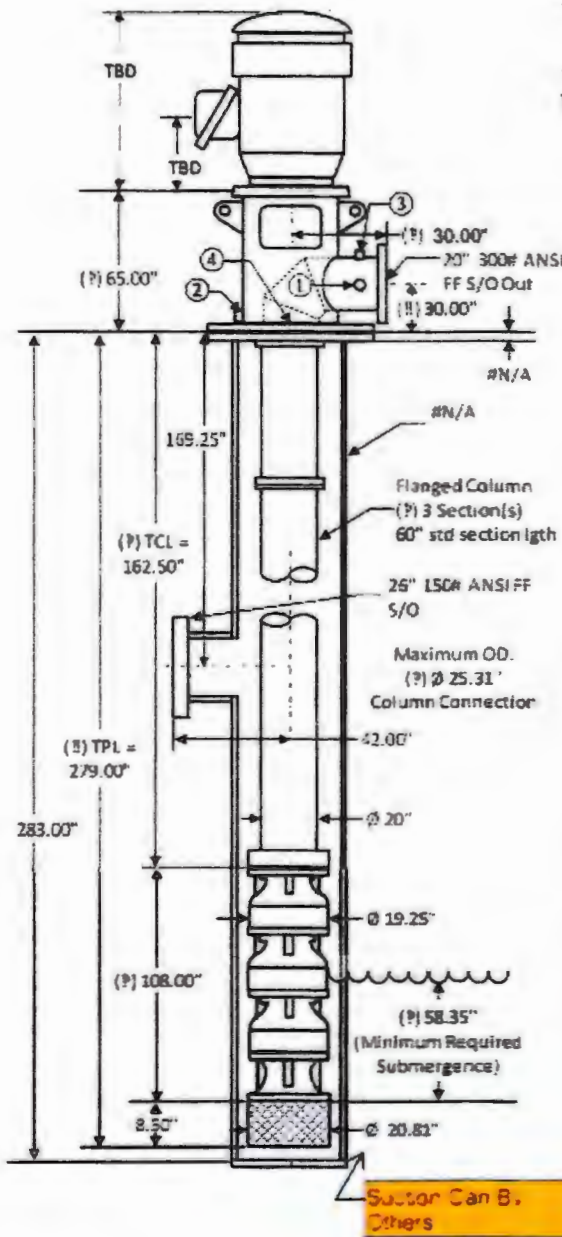

- Model: SM20M - 4 Stages
- Rated Cond: 5757 gpm @ 555 ft ldh
- Rated Speed: 1770 rpm
- Rated Power: 956 hp
- Column: 20" Flanged
- Line-Shaft: 2-11/16" Threaded
- Discharge Head: 20" Fabricated
- Seal Style: Packing
- Motor Operation: Constant Speed
- Motor Type: VSS
- Hydraulic Thrust: 15556.23 lbf
- Rotating Assy. Wt: 976.92 lbf
- Standard Duty Lifting Lugs Gr. A Shackel Minimum

Ports (As Applicable)

- ① - 1/2 in. NPT Gauge tap
- ② - 3/4 in. NPT Drain tap
- ③ - 1 in. NPT Prelube / ARV tap
- ④ - 1/2 in. NPS Bypass thru tap

(#) - Specified by Customer
(?) - Subject to Change Pending Engineering Review

NOT Approved for Construction

Date :	2025-11-04	Customer :	Gp Jager
Quote / Order # :	25201	Job Name / Description :	Pasaic Valley Replacement

- Model : SM20M - 4 Stages
- Rated Condition : 5757 gpm @ 555 ft tdh
- Rated Speed : 1770 rpm
- Rated Power : 956 hp

- Bowl Lateral : 1.50 in
- Impeller Setting : 0.125 in
- Total Lateral Adjustment : 0.137 in

- Shut-Off Head : 919 ft tdh (398.31 psiq)
- AOR : Consult Factory
- Capacity @ 3 ft/s : 2668.36 gpm
- Flow Velocity : 6.47 ft/s @ Rated Condition (20" Col. w/ 2-11/16" Shaft)

- NPSHr : 43.2 ft @ Rated Condition
- Minimum Submergence : 58.35 in @ Rated Condition
- Hydraulic Friction : 0.311 ft @ Rated Condition

- NPSHa : 32 ft
- Pumping Level : ft
- Discharge Pressure : 240 psiq (554.4 ft) @ Rated Condition (+ Inlet Pressure)

- Bowl-Shaft Limit : 1388 hp (2-7/16" Keyed impeller 17-4 PH)
- Bowl-Shaft Coupling Limit : 2184 hp (2-11/16" Threaded 416 SS HT)
- Line-Shaft Limit : 1729 hp (2-11/16" Threaded 416 SS HT)
- Line-Shaft Coupling Limit : 2184 hp (2-11/16" Threaded 416 SS HT)
- Mechanical Friction : 3.01 hp
- Total Load : 959.01 hp

- Bowl Efficiency : 84.7 %
- Pump Efficiency : 84.39 %
- Motor Efficiency : %
- Unit (Motor+Pump) Efficiency : 0 %

- Pump Assembly Inertia : 49.41 lbm·ft²
- Hydraulic Thrust : 15556.23 lbf
- Rotating Assembly Weight : 976.92 lbf
- Total Estimated Pump Weight : 7500 lbf
- Motor Weight : 4400 lbf

Notes:

OFFICE OF THE COMPTROLLER

CERTIFICATION OF AVAILABILITY OF FUNDS

It is hereby certified that subject to Commission approval of future Budgets, with respect to multi-budget year contracts, there are or will be sufficient available funds for expenditures to be incurred as a result of any contract or commitment to be entered into by Passaic Valley Water Commission as follows:

Description of Project or Contract: "Replacement of Two (2) Pumps at the Morris County Pump Station" under the PVSC Purchasing Cooperative, Contract B369-14
Precision Electric Motor Works

Amount of Project or Contract: \$306,652.50

1. Acct: #- 001-0901-419-95-37
CAPITAL – PUMP SYS IMPRVMT-REMOTE
2. Specific Appropriation to which expenditures will be charged:
CAPITAL 2026

Comments: \$153,326.25 per pump for a total of \$306,652.50

Date of Certification: March 25, 2026

Certified: \$306,652.50

Yitzhak Weiss
Comptroller and Chief Financial Officer

YW:lb

RESOLUTION NO. 26-052

PASSAIC VALLEY WATER COMMISSION

**RESOLUTION AUTHORIZING THE PROCUREMENT OF MOTOR PARTS
NECESSARY FOR THE REPAIR OF INDUSTRIAL PUMP #4
UTILIZING THE PVSC PURCHASING COOPERATIVE,
CONTRACT #B454-18**

DATE OF ADOPTION: MARCH 25, 2026

Introduced by Commissioner: **RON VAN RENSA LIER**

Seconded by Commissioner: **RUBY N. COTTON**

WHEREAS, it was discovered that the motor for Industrial Pump Number 4 at the Little Falls Water Treatment Plant is damaged and inoperable. This pump conveys water from the Little Falls Water Treatment Plant to the 180' gradient and is crucial for operations and cannot operate without a working motor; and

WHEREAS, Chief Operating Officer Michael Marotta prepared a Memorandum dated March 12, 2026 (the "Memorandum") describing the immediate need for repair (See **Exhibit A**); and

WHEREAS, PVWC has elected to repair the above-referenced Industrial Pump #4 using Universal Electric Motor Service, Inc. of Hackensack, New Jersey (the "Awardee") under the Cooperative, with the cost of the motor parts necessary for the repair being \$65,306.00; a copy of the quotation number 173632 is attached hereto as **Exhibit B**; and

WHEREAS, the Passaic Valley Sewerage Commission Purchasing Cooperative, Contract B454-18, (the "Co-op") shall be used for the procurement of the motor parts necessary for the repair of Industrial Pump #4; and

WHEREAS, in accordance with N.J.S.A. 40A:11-12, PVWC may purchase goods or services under contracts entered into on behalf of the State by the Division of Purchase and Property in the Department of the Treasury; and

WHEREAS, PVWC's Chief Financial Officer has certified, with respect hereto, that funds are currently available for said purpose and a copy of the said certification is attached hereto and made a part hereof as **Exhibit C.**

NOW, THEREFORE, BE IT RESOLVED, by Passaic Valley Water Commission, in the County of Passaic, New Jersey;

1. That the Cooperative Pricing Agreement for motor parts necessary to the repair of the above-referenced Industrial Pump #4 is hereby awarded to the Awardee as set forth hereinabove; and
2. That the appropriate officers and employees of PVWC are hereby authorized and directed to perform such acts and execute such documents as are consistent herewith, with respect to the Cooperative Pricing Agreement as set forth hereinabove.

RECORD OF COMMISSION VOTE ON FINAL PASSAGE

	AYE	NAY	ABSTAIN	ABSENT
COTTON, R.	<u>X</u>	___	___	___
DEPADUA, C.	<u>X</u>	___	___	___
FRIEND, G.	<u>X</u>	___	___	___
LEVINE, J.	<u>X</u>	___	___	___
SANCHEZ, R.	<u>X</u>	___	___	___
VAN RENSALIER, R.	<u>X</u>	___	___	___
RIZZI, D.	<u>X</u>	___	___	___

Adopted at a meeting of Passaic Valley Water Commission.



DEBORAH RIZZI
 President

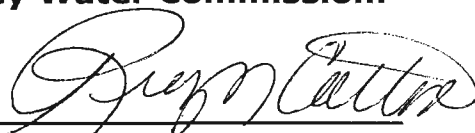

RUBY N. COTTON
 Secretary

This Resolution, when adopted, must remain in the custody of the Administrative Secretary.

CERTIFICATION

I, LOUIS AMODIO, Administrative Secretary of the Passaic Valley Water Commission in the County of Passaic, and the State of New Jersey do hereby certify that the foregoing Resolution is a true copy thereof of the foregoing Resolution duly passed and adopted by a majority of a legal quorum of the full membership of the Passaic Valley Water Commission at its duly noticed and convened meeting of the said Commission on March 25, 2026.

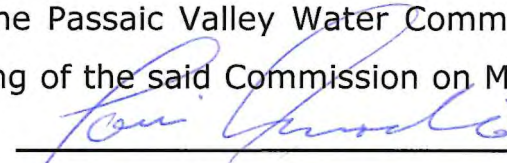

LOUIS AMODIO
 Administrative Secretary

EXHIBIT A



Executive Director
James Mueller, PE

Commissioners
Deborah Rizzi, President, Clifton
Carmen DePadua, Vice President, Paterson
Ronald Van Rensalier, Treasurer, Passaic
Ruby N. Cotton, Secretary, Paterson
Gerald Friend, Commissioner, Clifton
Jeffrey Levine, Commissioner, Paterson
Rigo Sanchez, Commissioner, Passaic

Memorandum for Industrial Pump #4 Motor Parts

TO: Lisa Bresemann

FROM: Michael Marotta, Chief Operating Officer

DATE: March 12, 2026

SUBJECT: Industrial Pump #4 Motor Parts (PVSC CO-OP B454-18)

Industrial Pump #4 is one of 5 horizontal split-case pumps that convey water from the Little Falls Water Treatment Plant to the 180' gradient. These 5 pumps consist of two 18MGD pumps, and three 28MGD pumps. Industrial Pump #4 is one of three 28 MGD pumps in this lineup.

As of 02/01/2026 only one (Industrial Pump #5) of our three 28 MGD pumps is operational. Additionally, Industrial Pump #5 is currently running 24/7/365 to meet system demands, with no redundancy in the event of failure.

During the summer months our system often demands operation of two of the three 28 MGD pumps and one 18 MGD pump simultaneously, leaving one of the three 28MGD and one of two 18 MGD for redundancy and rotational purposes. With only one of these three currently operational, meeting peak demand as well as fire flow demand would pose significant operational challenges and risks, further stressing our system and our pumping station. At this point in time, we lack rotation and redundancy with this needed pumping capacity.

The parts have an estimated lead time of 22 weeks. Once the parts are at the shop, we will then receive a quote for the complete repair.

There are no quotes.

Industrial #4 Motor is in Universal's shop for an estimate, it would cost more money to put it back together and take it to get another quote.

PASSAIC VALLEY WATER COMMISSION
1525 MAIN AVENUE - P.O. BOX 230
CLIFTON, NEW JERSEY 07011
(973) 340-4300

Total Cost of repair is: \$65,306.00

Michael Marotta



Chief Operating Officer

PASSAIC VALLEY WATER COMMISSION
1525 MAIN AVENUE • P.O. BOX 230
CLIFTON, NEW JERSEY 07011
(973) 340-4300

EXHIBIT B

<< QUOTE >>



Universal Electric Motor Service, Inc.
 131 S Newman St.
 Hackensack, NJ 07601
 (201)-968-1000
 www.uemotor.com

PAGE 1
 QUOTE DATE 3/10/2026
 QUOTE NO 173632
 TOTAL DUE 65,306.00

S 150225
 O PASSAIC VALLEY WATER COMM.
 L PVSC CO-OP B454-18
 D 1525 MAIN AVENUE
 T ATTN: ACCOUNTS PAYABLE
 O CLIFTON, NJ 07011

S 000001
 H PASSAIC VALLEY WATER
 I ATTN: TOM
 P 800 UNION AVE
 RE: INDUSTRIAL PUMP MOTOR RECTIFIER &
 T DIODE WHEEL ASSEMBLY
 O LITTLE FALLS, NJ

SLS1	DUE DATE	DISC DUE DATE	ORDER NO	ORDER DATE	SHIP NO	
950	4/9/2026	3/10/2026	00181145	3/10/2026		
TERMS	DESCRIPTION	CUSTOMER PO NO	SHIP VIA		SHIP DATE	
NET 30		NEEDPO	Our Truck			
ITEM ID		UNITS	ORDERED	SHIPPED	UNIT PRICE	EXTENSION
EM/WEG		EA	1.00	0.00	45,686.00	45,686.00
RECTIFIER ASSEMBLY- REF (145C432G04) & S/N-2-72-1910-11 24 WEEK LEAD TIME PER MOTOR S/N- 1-72-1910-11						
EM/WEG		EA	1.00	0.00	12,920.00	12,920.00
RESISTOR MTG ASSEMBLY /FDR ASSEMBLY 10-12 WEEK LEAD TIME						
EM/WEG		EA	4.00	0.00	15.00	60.00
BOLT HEX UNC3/8-18 X 1 1/2" PT ZN ELECT G5 2 WEEK LEAD TIME						
EM/WEG		EA	4.00	0.00	15.00	60.00
WASHER SPLIT LOCK 3/8" STEEL 2 WEEK LEAD TIME						
EM/WEG		EA	4.00	0.00	15.00	60.00
WASHER FLAT 3/8" STEEL 2 WEEK LEAD TIME						
EM/WEG		EA	4.00	0.00	15.00	60.00
BOLT HEX UNC 5/16"-18 X 1" PT BLACK 12.9 2 WEEK LEAD TIME						
EM/WEG		EA	4.00	0.00	15.00	60.00
WASHER SPLIT LOCK 5/16" STEEL 2 WEEK LEAD TIME						
EM/WEG		EA	1.00	0.00	6,400.00	6,400.00
LEAD CONNCTION ASSEMBLY 4 WEEK LEAD TIME						

<< QUOTE >>



Universal Electric Motor Service, Inc.
 131 S Newman St.
 Hackensack, NJ 07601
 (201)-968-1000
 www.uemotor.com

PAGE 2
 QUOTE DATE 3/10/2026
 QUOTE NO 173632
 TOTAL DUE 65,306.00

S 150225
 O PASSAIC VALLEY WATER COMM.
 L PVSC CO-OP B454-18
 D 1525 MAIN AVENUE
 T ATTN: ACCOUNTS PAYABLE
 O CLIFTON, NJ 07011

S 000001
 H PASSAIC VALLEY WATER
 I ATTN: TOM
 P 800 UNION AVE
 T RE: INDUSTRIAL PUMP MOTOR RECTIFIER &
 O DIODE WHEEL ASSEMBLY
 LITTLE FALLS, NJ

SLS1	DUE DATE	DISC DUE DATE	ORDER NO	ORDER DATE	SHIP NO
950	4/9/2026	3/10/2026	00181145	3/10/2026	

TERMS DESCRIPTION	CUSTOMER PO NO	SHIP VIA	SHIP DATE
NET 30	NEEDPO	Our Truck	

ITEM ID	UNITS	ORDERED	SHIPPED	UNIT PRICE	EXTENSION
---------	-------	---------	---------	------------	-----------

TAXABLE	NONTAXABLE	FREIGHT	SALES TAX	MISC	TOTAL
0.00	65,306.00	0.00	0.00	0.00	65,306.00
TOTAL DUE					65,306.00

"Providing Outstanding Service since 1946"
MOTORS • PUMPS • VALVES • CONTROLS • VENTILATION

EXHIBIT C

OFFICE OF THE COMPTROLLER

CERTIFICATION OF AVAILABILITY OF FUNDS

It is hereby certified that subject to Commission approval of future Budgets, with respect to multi-budget year contracts, there are or will be sufficient available funds for expenditures to be incurred as a result of any contract or commitment to be entered into by Passaic Valley Water Commission as follows:

Description of Project or Contract: "Repair Parts for Motor for Industrial Pump #4 at the LFWTP" under the Passaic Valley Sewerage Commission Purchasing Cooperative, Contract B454-18
Universal Electric Motor Service

Amount of Project or Contract: \$65,306.00

1. Acct: # - 001-0901-419-95-36
CAPITAL – PUMP SYS IMPRVMT-PLANT
2. Specific Appropriation to which expenditures will be charged:
CAPITAL 2026

Date of Certification: March 25, 2026

Certified: \$65,306.00

Yitzchak Weiss
Comptroller and Chief Financial Officer

YW:lb

RESOLUTION NO. 26-053

PASSAIC VALLEY WATER COMMISSION

**RESOLUTION AUTHORIZING THE PVWC TO PROCURE
TWO (2) 2026 FORD RANGER 4X4 SUPERCREW TRUCKS
UTILIZING THE NEW JERSEY PURCHASING COOPERATIVE,
CONTRACT BC BID, 24-43**

DATE OF ADOPTION: MARCH 25, 2026

Introduced by Commissioner: **RON VAN RENSALIER**

Seconded by Commissioner: **RUBY N. COTTON**

WHEREAS, the Commission desires to procure two (2) 2026 Ford Ranger 4x4 SuperCrew Trucks to replace two (2) trucks that are nearing the end of their useful life; and

WHEREAS, the New Jersey Purchasing Cooperative, Contract BC BID, 24-43, (the "Co-op") shall be used for the procurement of the two (2) 2026 Ford Ranger 4x4 SuperCrew Trucks; and

WHEREAS, in accordance with N.J.S.A. 40A:11-12, PVWC may purchase goods or services under contracts entered into on behalf of the State by the Division of Purchase and Property in the Department of the Treasury; and

WHEREAS, PVWC has elected to procure the above-referenced vehicle from Route 23 Automall located in Butler, New Jersey (the "Awardee") under the "Co-op", in the amount of \$38,531.90 per truck for a price of \$77,063.80, a copy of the quotation number PVWCR4P3 is attached hereto as **Exhibit A**; and

WHEREAS, N.J.S.A. 40A:11-12 of the Local Public Contracts Law provides for the awarding of said contract to the Awardee; and

WHEREAS, PVWC's Chief Financial Officer has certified, with respect hereto, that funds are currently available for said purpose and a copy of the said certification is attached hereto and made a part hereof as **Exhibit B**.

NOW, THEREFORE, BE IT RESOLVED, by Passaic Valley Water Commission, in the County of Passaic, New Jersey;

1. That the Cooperative Pricing Agreement for procurement of the above-referenced two (2) 2026 Ford Ranger 4x4 SuperCrew Trucks is hereby awarded to the Awardee as set forth hereinabove; and
2. That the appropriate officers and employees of PVWC are hereby authorized and directed to perform such acts and execute such documents as are consistent herewith, with respect to the Cooperative Pricing Agreement as set forth hereinabove.

RECORD OF COMMISSION VOTE ON FINAL PASSAGE

	AYE	NAY	ABSTAIN	ABSENT
COTTON, R.	<u>X</u>	---	---	---
DEPADUA, C.	<u>X</u>	---	---	---
FRIEND, G.	<u>X</u>	---	---	---
LEVINE, J.	<u>X</u>	---	---	---
SANCHEZ, R.	<u>X</u>	---	---	---
VAN RENSA LIER, R.	<u>X</u>	---	---	---
RIZZI, D.	<u>X</u>	---	---	---

Adopted at a meeting of Passaic Valley Water Commission.

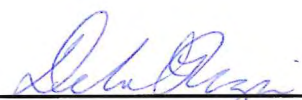

DEBORAH RIZZI
 President



RUBY N. COTTON
 Secretary

This Resolution, when adopted, must remain in the custody of the Administrative Secretary.

CERTIFICATION

I, LOUIS AMODIO, Administrative Secretary of the Passaic Valley Water Commission in the County of Passaic, and the State of New Jersey do hereby certify that the foregoing Resolution is a true copy thereof of the foregoing Resolution duly passed and adopted by a majority of a legal quorum of the full membership of the Passaic Valley Water Commission at its duly noticed and convened meeting of the said Commission on March 25, 2026.

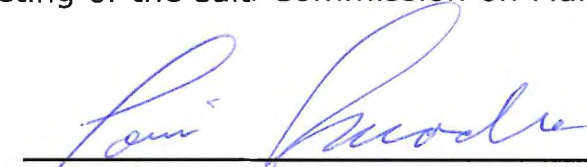

LOUIS AMODIO
 Administrative Secretary

EXHIBIT A

Prepared for: Mr. Mike Marotta, General Supervisor, Passaic Valley Water Commission
800 Union Boulevard
Totowa, NJ 07512
Office: 973-237-2028

2026 Ranger 4x4 SuperCrew 5' box 128.7" WB XL (R4P)
Price Level: 625



Client Proposal

Prepared by:
Dave Armiger
Office: 973-838-0800X122
Email: darmiger@23automall.com
Quote ID: PVWCR4P3
Date: 03/06/2026



ROUTE 23 AUTOMALL | NJ COOPERATIVE PURCHASING , COOPERATIVE, BC BID, 24-43
Office: 973-838-0800 | Fax: 973-838-5572

1



2026 Ranger 4x4 SuperCrew 5' box 128.7" WB XL (R4P)

Price Level: 625 | Quote ID: PVWCR4P3

Selected Equip & Specs

Dimensions

* Conventional Capacity: 7,500 lbs. * GCWR: 12,590 lbs. * Front brake diameter: 12.2" * Rear brake diameter: 12.1" * Cargo box length: 59.6" * Cargo box min width: 48.2" * Cargo box volume: 48.5 cu.ft. * Pickup box depth: 20.8" * Cargo box max width: 62.4" * Cargo box tailgate width: 55.6" * Cargo box length feet: 5.0 * Vehicle body length: 210.6" * Vehicle body width: 75.5" * Vehicle body height: 74.4" * Wheelbase: 128.7" * Vehicle turning radius: 21.2' * Front track: 63.8" * Rear track: 63.8" * Front bumper to back of cab: 143.2" * Total passenger volume: 98.3 cu.ft. * Headroom first-row: 41.0" * Headroom second-row: 38.3" * Leg room first-row: 43.2" * Leg room second-row: 34.6" * Shoulder room first-row: 57.1" * Shoulder room second-row: 56.7" * Hip room first-row: 55.9" * Hip room second-row: 54.1"

Powertrain

* Spark ignition system * EcoBoost 2.3L I-4 gasoline direct injection, DOHC, Ti-VCT variable valve control, intercooled turbo, engine with 270HP * Engine cylinders: I-4 * Horsepower: 270 HP@5500 RPM * Torque: 310 lb.-ft.@3000 RPM * Radiator * Auto stop-start engine * Driver selectable drivetrain mode * 10-speed automatic * Part-time 4WD * Four-wheel drive * Recommended fuel: regular unleaded * Easy Fuel capless fuel filler * All-speed ABS and driveline traction control * Electronic transfer case shift * Auto locking hub control

Fuel Economy and Emissions

* Fuel economy (city/highway/combined): 20 mpg/24 mpg/22 mpg * Fuel economy city: 20 mpg * Fuel economy combined: 22 mpg * Fuel economy highway: 24 mpg * Gasoline secondary fuel type * LEV3-SULEV30 emissions

Suspension and Handling

* Standard ride suspension * Gas-pressurized front shock absorbers * Gas-pressurized rear shock absorbers

Driveability

* 4-wheel disc brakes * Front ventilated disc brakes * 4-wheel antilock (ABS) brakes * Four channel ABS brakes * Electronic parking brake * Post Collision Braking automatic post-collision braking system * Brake assist system * Hill start assist * Independent front suspension * Short and long arm front suspension * Front anti-roll bar * Front coil springs * Rigid axle rear suspension * Leaf spring rear suspension * Speed sensitive power steering * Electric power-assist steering system * Rack-pinion steering * 2-wheel steering system

Body Exterior

* Trailer wiring harness * 4 doors * Drop-in pickup bed liner * Standard style pickup box * Pickup bed-rail protectors * Monotone paint * Grey wheel well trim * Black side window trim * Black door handles * Black windshield trim * Body-coloured front bumper * 2 front tow hooks * Black rear bumper * Rear bumper step * Body-coloured front bumper rub strip * Black grille * Standard style side mirrors * Black door mirrors * Conventional left rear passenger door * Conventional right rear passenger door * Tailgate * P255/70RS17 AT BSW front and rear tires * 17 x 7.5-inch front and rear silver aluminum wheels

Convenience

Prices and content availability as shown are subject to change and should be treated as estimates only. Actual base vehicle, package and option pricing may vary from this estimate because of special local pricing, availability or pricing adjustments not reflected in the dealer's computer system. See salesperson for the most current information.



2026 Ranger 4x4 SuperCrew 5' box 128.7" WB XL (R4P)

Price Level: 625 | Quote ID: PVWCR4P3

Selected Equip & Specs (cont'd)

• SYNC 4 911 Assist emergency SOS system via mobile device • Bluetooth handsfree wireless device connectivity • SYNC 4 AppLink/Apple CarPlay/Android Auto smart device wireless mirroring • FordPass App mobile app access • 4G Modem mobile hotspot internet access • 2 USB ports

Safety and Security

• Driver front impact airbag • Seat mounted side impact driver airbag • Safety Canopy System curtain first and second-row overhead airbags • Passenger front impact airbag • Seat mounted side impact front passenger airbag • Airbag occupancy sensor • 6 airbags • Rear seat center 3-point seatbelt • Front height adjustable seatbelts • Front seatbelt pretensioners • 2 seatbelt pre-tensioners • SecuriLock immobilizer • Vehicle tracker • Security system • Remote panic alarm • Lane Keeping Alert • Pre-Collision Assist with Automatic Emergency Braking (AEB) forward collision mitigation • Pedestrian impact prevention • Restricted driving mode • Reverse Camera rear mounted camera • AdvanceTrac w/Roll Stability Control electronic stability control system with anti-rollover • Manual rear child safety door locks

Dimensions

General Weights

Curb weight	4,462 lbs.	Rear curb weight	1,916 lbs.
GVWR	6,270 lbs.	Payload	1,763 lbs.

Trailing Weights

• Conventional capacity	7,500 lbs.	• GCWR	12,590 lbs.
-------------------------	------------	--------	-------------

Front Weights

Front curb weight	2,547 lbs.	GAWR front	3,130 lbs.
-------------------	------------	------------	------------

Rear Weights

GAWR rear	3,570 lbs.
-----------	------------

Off Road

Min ground clearance	9.3"	Loading floor height	34.7"
Approach angle	30.2	Departure angle	25.8

Exterior Measurements

Vehicle body length	210.6"	Vehicle body width	75.5"
Vehicle body height	74.4"	Wheelbase	128.7"
Front brake diameter	12.2"	Cargo box length	59.6"
Rear brake diameter	12.1"	Cargo box min width	48.2"
Cargo box volume	48.5 cu.ft.	Pickup box depth	20.8"
Cargo box max width	62.4"	Cargo box tailgate width	55.6"
Cargo box length feet	5.0	Front track	63.8"
Rear track	63.8"	Vehicle turning radius	21.2'
Front bumper to back of cab	143.2"		

Interior Volume

Total passenger volume	98.3 cu.ft.
------------------------	-------------

Prices and content availability as shown are subject to change and should be treated as estimates only. Actual base vehicle, package and option pricing may vary from this estimate because of special local pricing, availability or pricing adjustments not reflected in the dealer's computer system. See salesperson for the most current information.

Prepared for: Mr. Mike Marotta

General Supervisor, Passaic Valley Water Commission

Prepared by: Dave Arniger

ROUTE 23 AUTOMALL | NJ COOPERATIVE PURCHASING COOPERATIVE BC BID

03/06/2028

| 24-43



2026 Ranger 4x4 SuperCrew 5' box 128.7" WB XL (R4P)

Price Level: 625 | Quote ID: PVWCR4P3

Selected Equip & Specs (cont'd)

Third gear ratio	2.149	Fourth gear ratio	1.769
Fifth gear ratio	1.521	Sixth gear ratio	1.275
Reverse gear ratio	4.885	Seventh gear ratio	1
Eighth gear ratio	0.853	Ninth gear ratio	0.689
Tenth gear ratio	0.636	Selectable mode transmission	Selectable mode transmission
Sequential shift control	SelectShift Sequential shift control		
Drive Type			
4WD type	Part-time 4WD	Drive type	Four-wheel drive
Drivetrain			
Axle ratio	3.73		
Exhaust			
Tailpipe	Stainless steel single exhaust		
Fuel			
Fuel type	regular unleaded		
Fuel Tank			
Capless fuel filler	Easy Fuel capless fuel filler	Fuel tank capacity	17.99 gal.
Drive Feature			
Traction control	All-speed ABS and driveline traction control	Locking hub control	Auto locking hub control
Transfer case	Electronic transfer case shift		

Fuel Economy and Emissions

Fuel Economy

Secondary fuel type	Gasoline secondary fuel type	Fuel economy combined	22 mpg
Fuel economy city	20 mpg	Fuel economy highway	24 mpg
Fuel economy (city/highway/combined)	20 mpg/24 mpg/22 mpg	Fuel economy status	Previous year fuel economy status

Emissions

Emissions	LEV3-SULEV30 emissions	Emissions tiers	Tier 3 Bin 30 emissions
-----------	------------------------	-----------------	-------------------------

Green Values

Greenhouse gas score	5.00 GG	Energy Impact Score (Barrels per year)	13.5
Carbon FP / Tailpipe and upstream total GHG (CO2, tons per year)	8.0		

Suspension and Handling

Prices and content availability as shown are subject to change and should be treated as estimates only. Actual base vehicle, package and option pricing may vary from this estimate because of special local pricing, availability or pricing adjustments not reflected in the dealer's computer system. See salesperson for the most current information.

Prepared for: Mr. Mike Marotta

General Supervisor, Passaic Valley Water Commission

Prepared by: Dave Armiger

ROUTE 23 AUTOMALL | NJ COOPERATIVE PURCHASING COOPERATIVE BC BID

03/06/2026

| 24-43



2026 Ranger 4x4 SuperCrew 5' box 128.7" WB XL (R4P)

Price Level: 625 | Quote ID: PVWCR4P3

Selected Equip & Specs (cont'd)

Front Tires

Aspect	70	Diameter	17"
Sidewalls	BSW	Speed	S
Tread	AT	Type	P
Width	255mm		

Rear Tires

Aspect	70	Diameter	17"
Sidewalls	BSW	Speed	S
Tread	AT	Type	P
Width	255mm		

Body Exterior

Trailer

• Towing class	Class IV tow rating	• Towing hitch	Trailer hitch
• Towing wiring harness	Trailer wiring harness	Towing trailer sway	Trailer sway control

Exterior Features

Box style	Standard style pickup box	• Bed liner	Drop-in pickup bed liner
Number of doors	4 doors		

Body

Body panels Galvanized steel and aluminum body panels with side impact beams

Spare Tire

Spare tire	Full-size spare tire with steel wheel	Spare tire location	Crank-down spare tire
------------	---------------------------------------	---------------------	-----------------------

Convenience

Technology

Built-in virtual assistant SYNC 4 with Enhanced Voice Recognition (Alexa-Built-In) built-in virtual assistant

Door Locks

Door locks	Power door locks with 2 stage unlocking	Keyfob door locks	Keyfob activated door locks
All-in-one key	All-in-one remote fob and ignition key	Auto door locks	Auto-locking doors
Tailgate control	Power tailgate/rear door lock		

Cruise Control

Cruise control Cruise control with steering wheel mounted controls

Rear View Mirror

Day/Night rearview mirror Day/Night rearview mirror

Prices and content availability as shown are subject to change and should be treated as estimates only. Actual base vehicle, package and option pricing may vary from this estimate because of special local pricing, availability or pricing adjustments not reflected in the dealer's computer system. See salesperson for the most current information.

Prepared for: Mr. Mike Marotta

General Supervisor, Passaic Valley Water Commission

Prepared by: Dave Armiger
03/06/2026

ROUTE 23 AUTOMALL | NJ COOPERATIVE PURCHASING COOPERATIVE BC BID
| 24-43



2026 Ranger 4x4 SuperCrew 5' box 128.7" WB XL (R4P)

Price Level: 625 | Quote ID: PVWCR4P3

Selected Equip & Specs (cont'd)

Rear under seat ducts
Rear under seat climate control ducts

Headliner

Headliner material Cloth headliner material Headliner coverage Full headliner coverage

Floor Trim

Floor covering Full vinyl floor covering Floor coverage Full floor coverage

Second-Row Seat Trim

Rear seat upholstery Cloth rear seat upholstery Rear seatback upholstery Carpet rear seatback upholstery

Steering Wheel

Steering wheel material Urethane steering wheel Steering wheel telescopic Manual telescopic steering wheel

Steering wheel tilt Manual tilting steering wheel

Seats and Trim

Seat Capacity

Seating capacity 5

Front Seats

Driver seat direction Driver seat with 6-way directional controls Height adjustable driver seat Manual height adjustable driver seat

Driver seat fore/aft control Manual driver seat fore/aft control Passenger seat direction Front passenger seat with 6-way directional controls

Split front seats Bucket front seats Reclining passenger seat Manual reclining passenger seat

Height adjustable passenger seat Manual height adjustable control passenger seat Passenger seat fore/aft control Manual passenger seat fore/aft control

Front head restraints Height adjustable front seat head restraints Front head restraint control Manual front seat head restraint control

Armrests front center Front seat center armrest Reclining driver seat Manual reclining driver seat

Rear Seats

Bench seats Rear bench seat Rear seats fixed or removable Fixed rear seats

Folding second-row seats Full folding rear seats Rear seat direction Front facing rear seat

Rear seat folding position Fold-up rear seat cushion Rear head restraints Height adjustable rear seat head restraints

Rear head restraint control Manual rear seat head restraint control Number of rear head restraints 3 rear seat head restraints

Armrests rear Rear seat center armrest

Lumbar Seats

Prices and content availability as shown are subject to change and should be treated as estimates only. Actual base vehicle, package and option pricing may vary from this estimate because of special local pricing, availability or pricing adjustments not reflected in the dealer's computer system. See salesperson for the most current information.

Prepared for: Mr. Mike Marotta

General Supervisor, Passaic Valley Water Commission

Prepared by: Dave Armiger
03/06/2026

ROUTE 23 AUTOMALL | NJ COOPERATIVE PURCHASING COOPERATIVE BC BID
| 24-43



2026 Ranger 4x4 SuperCrew 5' box 128.7" WB XL (R4P)

Price Level: 625 | Quote ID: PVWCR4P3

Selected Equip & Specs (cont'd)

Oil pressure gauge	Oil pressure gauge	Transmission temperature gauge	Transmission fluid temperature gauge
Voltmeter	Voltmeter	Engine/electric motor temperature gauge	Engine/electric motor temperature gauge
Gauge cluster display size (inches)	8.00		

Instrumentation Warnings

Engine temperature warning	Engine temperature warning	Oil pressure warning	Oil pressure warning
Low fuel warning	Low fuel warning	Low washer fluid warning	Low washer fluid warning
Low brake fluid warning	Low brake fluid warning	Battery charge warning	Battery charge warning
Headlights on reminder	Headlights on reminder	Key in vehicle warning	Key in vehicle warning
Bulb warning	Bulb failure warning	Door ajar warning	Door ajar warning
Service interval warning	Service interval indicator	Low tire pressure warning	Tire specific low air pressure warning

Glass

Tinted windows	Deep tinted windows
----------------	---------------------

Headlights

Headlights	LED low and high beam headlights	Headlight type	Reflector headlights
Auto headlights	Autolamp auto on/off headlight control	Delay off headlights	Delay-off headlights
Auto high-beam headlights	Auto high-beam headlights	DRL preference setting	DRL preference setting

Front Windshield

Wipers	Variable intermittent front windshield wipers
--------	---

Interior Lighting

Illuminated entry	Illuminated entry	Variable panel light	Variable instrument panel light
Front reading lights	Front reading lights	Rear reading lights	Rear reading lights

Lights

Running lights	Daytime running lights	Interior courtesy lights	Fade interior courtesy lights
Fog lights	Front fog lights	High mount stop light	High mounted center stop light
Pickup box cargo light	Pickup box cargo light		

Technology and Telematics

Connectivity

Handsfree connectivity	Bluetooth handsfree wireless device	Smart device integration	SYNC 4 AppLink/Apple CarPlay/Android Auto smart device wireless mirroring
Emergency SOS system via mobile device	Emergency SOS SYNC 4 911 Assist emergency SOS system via mobile device		

Internet Access

Prices and content availability as shown are subject to change and should be treated as estimates only. Actual base vehicle, package and option pricing may vary from this estimate because of special local pricing, availability or pricing adjustments not reflected in the dealer's computer system. See salesperson for the most current information.

Prepared for: Mr. Mike Marotta

General Supervisor, Passaic Valley Water Commission

Prepared by: Dave Armiger

ROUTE 23 AUTOMALL | NJ COOPERATIVE PURCHASING COOPERATIVE BC BID

03/06/2026

| 24-43



2026 Ranger 4x4 SuperCrew 5' box 128.7" WB XL (R4P)

Price Level: 625 | Quote ID: PVWCR4P3

Warranty

Standard Warranty

Basic Warranty

Basic warranty

36 months/36,000 miles

Powertrain Warranty

Powertrain warranty

60 months/60,000 miles

Corrosion Perforation

Corrosion perforation warranty

60 months/unlimited

Roadside Assistance Warranty

Roadside warranty

60 months/60,000 miles

Prices and content availability as shown are subject to change and should be treated as estimates only. Actual base vehicle, package and option pricing may vary from this estimate because of special local pricing, availability or pricing adjustments not reflected in the dealer's computer system. See salesperson for the most current information.

15

Prepared for: Mr. Mike Marotta

General Supervisor, Passaic Valley Water Commission

Prepared by: Dave Armiger

ROUTE 23 AUTOMALL | NJ COOPERATIVE PURCHASING COOPERATIVE BC BID

03/06/2026

| 24-43



2026 Ranger 4x4 SuperCrew 5' box 128.7" WB XL (R4P)

Price Level: 625 | Quote ID: PVWCR4P3

As Configured Vehicle (cont'd)

Code	Description	MSRP
B	Cloth Front Bucket Seats <i>Includes 8-way manual adjustable driver including lumbar, 6-way manual adjustable passenger, driver and passenger manual reclining seats, flow-through console and floor shift.</i>	Included
Other Options		
128WB	128" Wheelbase	STD
PAINT	Monotone Paint Application	STD
STDRD	Radio: AM/FM Stereo <i>Includes 6 speakers and A and C USB ports.</i>	Included
	<i>Includes: - SYNC 4A Includes enhanced voice recognition communications and entertainment system, 10" center display, AppLink, 911 Assist and Apple CarPlay and Android Auto compatibility.</i>	
53R	Trailer Tow Package <i>Includes towing capability up to TBD lbs and 4-pin/7-pin wiring harness.</i>	\$535.00
	<i>Includes: - Class IV Trailer Hitch Receiver</i>	
86Q	Modular Drop-In Bedliner Ford accessory.	\$385.00
Exterior Color		
YZ_01	Oxford White	N/C
Interior Color		
BH_03	Ebony w/Cloth Front Bucket Seats	N/C
SUBTOTAL		\$37,770.00
Destination Charge		\$1,895.00
TOTAL		\$39,665.00

Prices and content availability as shown are subject to change and should be treated as estimates only. Actual base vehicle, package and option pricing may vary from this estimate because of special local pricing, availability or pricing adjustments not reflected in the dealer's computer system. See salesperson for the most current information.

Prepared for: Mr. Mike Marotta

General Supervisor, Passaic Valley Water Commission

Prepared by: Dave Armiger

ROUTE 23 AUTOMALL | NJ COOPERATIVE PURCHASING COOPERATIVE BC BID

03/06/2026

| 24-43



2026 Ranger 4x4 SuperCrew 5' box 128.7" WB XL (R4P)

Price Level: 625 | Quote ID: PVWCR4P3

Pricing Summary - Multiple Vehicles

Vehicle Quantity: 2

	MSRP
<i>Vehicle Pricing</i>	\$79,330.00
Subtotal	\$79,330.00

Pre-Tax Adjustments

Code	Description	MSRP
NJPA	NJ PURCHASING ALLIANCE	-\$2,266.20
Total		\$77,063.80

Customer Signature

Acceptance Date

Prices and content availability as shown are subject to change and should be treated as estimates only. Actual base vehicle, package and option pricing may vary from this estimate because of special local pricing, availability or pricing adjustments not reflected in the dealer's computer system. See salesperson for the most current information.

EXHIBIT B

OFFICE OF THE COMPTROLLER

CERTIFICATION OF AVAILABILITY OF FUNDS

It is hereby certified that subject to Commission approval of future Budgets, with respect to multi-budget year contracts, there are or will be sufficient available funds for expenditures to be incurred as a result of any contract or commitment to be entered into by Passaic Valley Water Commission as follows:

Description of Project or Contract: Procure "Two 2026 Ford Ranger 4x4 SuperCrew Trucks" through the NJ Cooperative Purchasing Agreement, Contract BC Bid 24-43
Route 23 Automall

Amount of Project or Contract: \$77,063.80

1. Acct: #- 001-0901-419-95-04
CAPITAL – VEHICLES
2. Specific Appropriation to which expenditures will be charged:
CAPITAL 2026

Comments: Cost per vehicle: \$38,531.90 for a total of \$77,063.80

Date of Certification: March 25, 2026

Certified: \$77,063.80

Yitzhak Weiss
Comptroller and Chief Financial Officer

YW:lb

RESOLUTION NO. 26-054

PASSAIC VALLEY WATER COMMISSION

**RESOLUTION AUTHORIZING THE PVWC TO PROCURE
TWO (2) 2026 FORD BRONCO SPORT 4 DOOR 4X4 BIG BEND TRUCKS
UTILIZING THE NEW JERSEY PURCHASING COOPERATIVE,
CONTRACT BC BID, 24-43**

DATE OF ADOPTION: MARCH 25, 2026

Introduced by Commissioner: **RON VAN RENSALEIR**

Seconded by Commissioner: **RUBY N. COTTON**

WHEREAS, the Commission desires to procure two (2) 2026 Ford Bronco Sport 4 Door 4X4 Big Bend Trucks to be to replace two (2) trucks that are nearing the end of their useful life; and

WHEREAS, the New Jersey Purchasing Cooperative, Contract BC BID, 24-43, (the "Co-op") shall be used for the procurement of the Bronco Sport 4 Door 4X4 Big Bend Trucks; and

WHEREAS, in accordance with N.J.S.A. 40A:11-12, PVWC may purchase goods or services under contracts entered into on behalf of the State by the Division of Purchase and Property in the Department of the Treasury; and

WHEREAS, PVWC has elected to procure the above-referenced vehicle from Route 23 Automall located in Butler, New Jersey (the "Awardee") under the "Co-op", in the amount of \$33,203.10 per truck for a price of \$66,406.20, a copy of the quotation number PVWCR9B is attached hereto as **Exhibit A**; and

WHEREAS, N.J.S.A. 40A:11-12 of the Local Public Contracts Law provides for the awarding of said contract to the Awardee; and

WHEREAS, PVWC's Chief Financial Officer has certified, with respect hereto, that funds are currently available for said purpose and a copy of the said certification is attached hereto and made a part hereof as **Exhibit B**.

NOW, THEREFORE, BE IT RESOLVED, by Passaic Valley Water Commission, in the County of Passaic, New Jersey;

1. That the Cooperative Pricing Agreement for procurement of the above-referenced two (2) 2026 Ford Bronco Sport 4 Door 4X4 Big Bend Trucks is hereby awarded to the Awardee as set forth hereinabove; and
2. That the appropriate officers and employees of PVWC are hereby authorized and directed to perform such acts and execute such documents as are consistent herewith, with respect to the Cooperative Pricing Agreement as set forth hereinabove.

RECORD OF COMMISSION VOTE ON FINAL PASSAGE

	AYE	NAY	ABSTAIN	ABSENT
COTTON, R.	<u>X</u>	---	---	---
DEPADUA, C.	<u>X</u>	---	---	---
FRIEND, G.	<u>X</u>	---	---	---
LEVINE, J.	<u>X</u>	---	---	---
SANCHEZ, R.	<u>X</u>	---	---	---
VAN RENSA LIER, R.	<u>X</u>	---	---	---
RIZZI, D.	<u>X</u>	---	---	---

Adopted at a meeting of Passaic Valley Water Commission.



DEBORAH RIZZI
 President



RUBY N. COTTON
 Secretary

This Resolution, when adopted, must remain in the custody of the Administrative Secretary.

CERTIFICATION

I, LOUIS AMODIO, Administrative Secretary of the Passaic Valley Water Commission in the County of Passaic, and the State of New Jersey do hereby certify that the foregoing Resolution is a true copy thereof of the foregoing Resolution duly passed and adopted by a majority of a legal quorum of the full membership of the Passaic Valley Water Commission at its duly noticed and convened meeting of the said Commission on March 25, 2026.

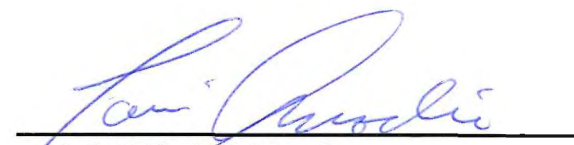

LOUIS AMODIO
 Administrative Secretary

EXHIBIT A

Prepared for: Mr. Mike Marotta, General Supervisor, Passaic Valley Water Commission
800 Union Boulevard
Totowa, NJ 07512
Office: 973-237-2028

2026 Bronco Sport 4dr 4x4 Big Bend (R9B)
Price Level: 630



Client Proposal

Prepared by:
Dave Armiger
Office: 973-838-0800X122
Email: darmiger@23automall.com
Quote ID: PVWCR9B
Date: 03/06/2026



ROUTE 23 AUTOMALL | NJ COOPERATIVE PURCHASING , COOPERATIVE, BC BID, 24-43
Office: 973-838-0800 | Fax: 973-838-5572

1

Prepared for: Mr. Mike Marotta

General Supervisor, Passaic Valley Water Commission

Prepared by: Dave Armiger
03/06/2026

ROUTE 23 AUTOMALL | NJ COOPERATIVE PURCHASING COOPERATIVE BC BID



| 24-43

2026 Bronco Sport 4dr 4x4 Big Bend (R9B)

Price Level: 630 | Quote ID: PVWCR9B

Table of Contents

Description	Page
Cover Page	1
Table of Contents	2
Selected Equip & Specs	3
Warranty	16
As Configured Vehicle	17
Pricing Summary - Single Vehicle	20
Pricing Summary - Multiple Vehicle	21

Prepared for: Mr. Mike Marotta

General Supervisor, Passaic Valley Water Commission

Prepared by: Dave Armiger

ROUTE 23 AUTOMALL | NJ COOPERATIVE PURCHASING COOPERATIVE BC BID

03/08/2026

| 24-43



2026 Bronco Sport 4dr 4x4 Big Bend (R9B)

Price Level: 630 | Quote ID: PVWCR9B

Selected Equip & Specs

Dimensions

• Conventional Capacity: 2,200 lbs. • GCWR: 6,305 lbs. • Vehicle body length: 172.7" • Vehicle body width: 74.3" • Vehicle body height: 70.2" • Wheelbase: 105.1" • Vehicle turning radius: 18.7" • Front track: 63.4" • Rear track: 62.8" • Interior rear cargo volume: 32.5 cu.ft. • Interior rear cargo volume with seats folded: 65.2 cu.ft. • Max interior rear cargo volume: 65.2 cu.ft. • Total passenger volume: 105.7 cu.ft. • Headroom first-row: 41.5" • Headroom second-row: 41.7" • Leg room first-row: 42.4" • Leg room second-row: 36.9" • Shoulder room first-row: 57.3" • Shoulder room second-row: 55.6" • Hip room first-row: 55.2" • Hip room second-row: 53.4"

Powertrain

• Spark ignition system • 1.5L I-3 port/direct injection, DOHC, variable valve control, intercooled turbo, engine with 181HP • Engine cylinders: I-3 • Horsepower: 181 HP@6000 RPM • Torque: 190 lb.-ft.@3000 RPM • Radiator • Auto stop-start engine • Terrain Management System driver selectable drivetrain mode • 8-speed automatic • Part and full-time 4WD • Four-wheel drive • Selectable Terrain Modes • Recommended fuel: regular unleaded • Easy Fuel capless fuel filler • All-speed ABS and driveline traction control • Electronic transfer case shift • Permanent locking hub control

Fuel Economy and Emissions

• Fuel economy (city/highway/combined): 25 mpg/30 mpg/27 mpg • Fuel economy city: 25 mpg • Fuel economy combined: 27 mpg • Fuel economy highway: 30 mpg • Gasoline secondary fuel type • LEV3-SULEV30 emissions

Suspension and Handling

• HOSS 1.0 off-road ride suspension • Gas-pressurized front shock absorbers • Gas-pressurized rear shock absorbers

Driveability

• 4-wheel disc brakes • Front ventilated disc brakes • 4-wheel antilock (ABS) brakes • Four channel ABS brakes • Electronic parking brake • Automatic brake hold • Brake assist system • Hill Start Assist • Independent front suspension • Strut front suspension • Front anti-roll bar • Front coil springs • Independent rear suspension • Rear anti-roll bar • Short and long arm rear suspension • Speed sensitive power steering • Electric power-assist steering system • Rack-pinion steering • Terrain Management System with G.O.A.T. Modes driver selectable steering effort • 2-wheel steering system

Body Exterior

• 4 doors • Roof rails • Monotone paint • Black bodyside cladding • Black wheel well trim • Black side window trim • Black door handles • Black front bumper • Black rear bumper • Grey grille • Standard style side mirrors • Black door mirrors • Conventional left rear passenger door • Conventional right rear passenger door • Liftgate rear cargo door • Active grille shutters • P225/65RH17 AS BSW front and rear tires • 17 x 7-inch front and rear grey aluminum wheels

Convenience

Price and content availability as shown are subject to change and should be treated as estimates only. Actual base vehicle, package and option pricing may vary from this estimate because of special local pricing, availability or pricing adjustments not reflected in the dealer's computer system. See salesperson for the most current information.

Prepared for: Mr. Mike Marotta

General Supervisor, Passaic Valley Water Commission

Prepared by: Dave Armiger

ROUTE 23 AUTOMALL | NJ COOPERATIVE PURCHASING COOPERATIVE BC BID

03/06/2026

| 24-43



2026 Bronco Sport 4dr 4x4 Big Bend (R9B)

Price Level: 630 | Quote ID: PVWCR08

Selected Equip & Specs (cont'd)

- Power door locks with 2 stage unlocking • Keyfob activated door locks • All-in-one remote fob and ignition key • Auto-locking doors • Intelligent Access proximity key with hands-free access and push button start • Power tailgate/rear door lock • Cruise control with steering wheel mounted controls • Adaptive Cruise Control with Stop-and-Go • Keyfob trunk control • Day/Night rearview mirror • Power first-row windows • Full floor console • Driver foot rest • Rear window defroster • Flip-up rear windshield • Yes rear windshield wipers • Front beverage holders • Standard glove box • 8 beverage holders • Driver and passenger door bins • Rear door bins • Rear beverage holders • Instrument panel bin • Retained accessory power • Trip computer • Over the air updates • PRND in IP

Comfort

- Automatic climate control • Cabin air filter • Rear under seat climate control ducts • Voice-activated climate control • Rear console climate control ducts • Cloth headliner material • Full headliner coverage • Full carpet floor covering • Carpet front floor mats • Full floor coverage • Cloth rear seat upholstery • Carpet rear seatback upholstery • Urethane steering wheel • Manual tilting steering wheel • Manual telescopic steering wheel

Seats and Trim

- Seating capacity: 5 • Bucket front seats • Driver seat with 6-way directional controls • Front passenger seat with 4-way directional controls • Height adjustable front seat head restraints • Manual front seat head restraint control • Front seat center armrest • Manual reclining driver seat • Manual height adjustable driver seat • Manual driver seat fore/aft control • Manual reclining passenger seat • Manual passenger seat fore/aft control • Fixed rear seats • Rear seats with manual fore and aft • Height adjustable rear seat head restraints • Rear bench seat • Rear seat center armrest • Cloth front seat upholstery

Entertainment Features

- 2 total number of 1st row displays • 13.2 inch primary display • Primary touchscreen display • SiriusXM with 360L AM/FM/Satellite radio • AM/FM/satellite • In-vehicle audio • AM radio • FM radio • SiriusXM with 360L satellite radio • Seek scan • Radio data system (RDS) • SYNC 4 external memory control • Internet radio capability • 3 month satellite trial subscription • Standard grade speakers • Speakers number: 6 • Steering wheel mounted audio controls • SYNC 4 voice activated audio controls • Speed sensitive volume • Bluetooth wireless audio streaming • Integrated roof audio antenna

Lighting, Visibility and Instrumentation

- Metal-look instrument panel insert • Digital/analog instrumentation display • Configurable instrumentation gauges • Trip odometer • Full gauge cluster screen • Digital clock • Compass • Exterior temperature display • Redundant digital speedometer • SmartGauge with EcoGuide ECO feedback display gauge • Driver information center • Tachometer • Engine/electric motor temperature gauge • Inclinometer • Gauge cluster display size (inches): 8.00 • Deep tinted windows • Projector beam headlights • LED low and high beam headlights • Autolamp auto on/off headlight control • Delay-off headlights • Auto High Beam auto high-beam headlights • DRL preference setting • Variable intermittent front windshield wipers • Speed sensitive wipers • Illuminated entry • Front reading lights • Rear reading lights • Variable instrument panel light • Illuminated ignition switch • LED daytime running lights • High mounted center stop light • LED brake lights • Fade interior courtesy lights

Technology and Telematics

Prices and content availability as shown are subject to change and should be treated as estimates only. Actual base vehicle, package and option pricing may vary from this estimate because of special local pricing, availability or pricing adjustments not reflected in the dealer's computer system. See salesperson for the most current information.

4



2026 Bronco Sport 4dr 4x4 Big Bend (R9B)

Price Level: 630 | Quote ID: PVWCR98

Selected Equip & Specs (cont'd)

• SYNC 4 911 Assist emergency SOS system via mobile device • Bluetooth handsfree wireless device connectivity • Apple CarPlay/Android Auto smart device wireless mirroring • Mobile app access • 5G Modem - Ford Connectivity Package mobile hotspot internet access • 4 USB ports

Safety and Security

• Driver front impact airbag • Seat mounted side impact driver airbag • Safety Canopy System curtain first and second-row overhead airbags • Passenger front impact airbag • Seat mounted side impact front passenger airbag • Airbag occupancy sensor • Driver side knee airbag • 7 airbags • Rear seat center 3-point seatbelt • Front height adjustable seatbelts • Front seatbelt pretensioners • 2 seatbelt pre-tensioners • SecuriLock immobilizer • FordPass Connect vehicle tracker • Security system • Remote panic alarm • Lane Centering hands-on cruise control • Lane-Keeping System • BLIS (Blind Spot Information System) • Pre-Collision Assist with Automatic Emergency Braking (AEB) forward collision mitigation • Rear Cross-Traffic Braking collision mitigation • Pre-Collision Assist with Pedestrian Detection • Driver Alert • Evasive Steering Assist evasion assist system • Level 2 - partial automation SAE Autonomy • Rear mounted camera • AdvanceTrac w/Roll Stability Control electronic stability control system with anti-rollover • Rear parking sensors • Manual rear child safety door locks • Tire mobility kit

Dimensions

General Weights

Curb weight	3,467 lbs.	GVWR	4,630 lbs.
-------------	------------	------	------------

Trailering Weights

Conventional capacity	2,200 lbs.	GCWR	6,305 lbs.
-----------------------	------------	------	------------

Off Road

Min ground clearance	7.8"	Max wading depth	17.7"
Approach angle	21.7	Departure angle	30.4

Exterior Measurements

Vehicle body length	172.7"	Vehicle body width	74.3"
Vehicle body height	70.2"	Wheelbase	105.1"
Front track	63.4"	Rear track	62.8"
Vehicle turning radius	18.7		

Interior Measurements

Interior rear cargo volume	32.5 cu.ft.	Max interior rear cargo volume	65.2 cu.ft.
Interior rear cargo volume with seats folded	65.2 cu.ft.		

Interior Volume

Total passenger volume	105.7 cu.ft.
------------------------	--------------

Headroom

Headroom first-row	41.5"	Headroom second-row	41.7"
--------------------	-------	---------------------	-------

Legroom

Leg room first-row	42.4"	Leg room second-row	36.9"
--------------------	-------	---------------------	-------

Prices and content availability as shown are subject to change and should be treated as estimates only. Actual base vehicle, package and option pricing may vary from this estimate because of special local pricing, availability or pricing adjustments not reflected in the dealer's computer system. See salesperson for the most current information.



2026 Bronco Sport 4dr 4x4 Big Bend (R9B)

Price Level: 630 | Quote ID: PVWCR9B

Selected Equip & Specs (cont'd)

Shoulder Room

Shoulder room first-row 57.3" Shoulder room second-row 55.6"

Hip Room

Hip room first-row 55.2" Hip room second-row 53.4"

Powertrain

Engine

Engine	1.5L I-3 port/direct injection, DOHC, variable valve control, intercooled turbo, engine with 181HP	Valves per cylinder	4
Engine cylinders	I-3	Engine location	Front mounted engine
Ignition	Spark ignition system	Engine mounting direction	Transverse mounted engine
Engine block material	Aluminum engine block	Cylinder head material	Aluminum cylinder head

Engine Specs

Displacement	1.5L	cc	91.4 cu.in.
Bore	3.31"	Stroke	3.54"
Compression ratio	11.0		

Engine Power

Horsepower	181 HP@6000 RPM	Torque	190 lb.-ft.@3000 RPM
------------	-----------------	--------	----------------------

Alternator

Alternator type Regular duty alternator

Battery

Battery type	Lead acid battery	Battery rating	760CCA
Battery run down protection	Battery run down protection		

Engine Extras

Radiator	Radiator	Start-stop engine	Auto stop-start engine
Drivetrain selectable	Terrain Management System driver selectable drivetrain mode		

Transmission

Transmission	8-speed automatic	Transmission electronic control	Transmission electronic control
Overdrive transmission	Overdrive transmission	Lock-up transmission	Lock-up transmission
First gear ratio	4.69	Second gear ratio	3.31
Third gear ratio	3.01	Fourth gear ratio	1.92
Fifth gear ratio	1.45	Sixth gear ratio	1
Reverse gear ratio	2.96	Seventh gear ratio	0.75

Prices and content availability as shown are subject to change and should be treated as estimates only. Actual base vehicle, package and option pricing may vary from this estimate because of special local pricing, availability or pricing adjustments not reflected in the dealer's computer system. See salesperson for the most current information.



2026 Bronco Sport 4dr 4x4 Big Bend (R9B)

Price Level: 630 | Quote ID: PVWCR9B

Selected Equip & Specs (cont'd)

Eighth gear ratio	0.62	Selectable mode transmission transmission	Selectable mode transmission
<i>Drive Type</i>			
4WD type	Part and full-time 4WD	Drive type	Four-wheel drive
<i>Drivetrain</i>			
Axle ratio	3.8		
<i>Exhaust</i>			
Tailpipe	Stainless steel quasi-dual exhaust		
<i>Fuel</i>			
Fuel type	regular unleaded		
<i>Fuel Tank</i>			
Capless fuel filler	Easy Fuel capless fuel filler	Fuel tank capacity	16.01 gal.
<i>Performance</i>			
Performance acceleration	8.25s	Performance quarter mile time	15.95s
Performance quarter mile speed	84.7 mph	Lateral acceleration (g)	.8g
Slalom speed	58.8 mph		
<i>Drive Feature</i>			
Traction control	All-speed ABS and driveline traction control	Locking hub control	Permanent locking hub control
Transfer case	Electronic transfer case shift		

Fuel Economy and Emissions

<i>Fuel Economy</i>			
Secondary fuel type	Gasoline secondary fuel type	Fuel economy combined	27 mpg
Fuel economy city	25 mpg	Fuel economy highway	30 mpg
Fuel economy (city/highway/combined)	25 mpg/30 mpg/27 mpg	Fuel economy status	Previous year fuel economy status
<i>Emissions</i>			
Emissions	LEV3-SULEV30 emissions	Emissions tiers	Tier 3 Bin 30 emissions
<i>Green Values</i>			
Greenhouse gas score	5.00 GG	Energy Impact Score (Barrels per year)	11.0
Carbon FP / Tailpipe and upstream total GHG (CO2, tons per year)	6.6		

Suspension and Handling

Suspension

Prices and content availability as shown are subject to change and should be treated as estimates only. Actual base vehicle, package and option pricing may vary from this estimate because of special local pricing, availability or pricing adjustments not reflected in the dealer's computer system. See salesperson for the most current information.



2026 Bronco Sport 4dr 4x4 Big Bend (R9B)

Price Level: 630 | Quote ID: PVWCR9B

Selected Equip & Specs (cont'd)

Suspension	HOSS 1.0 off-road ride suspension	Front shock absorbers	Gas-pressurized front shock absorbers
Rear shock absorbers	Gas-pressurized rear shock absorbers		

Driveability

Brakes

Brake type	4-wheel disc brakes	Ventilated brakes	Front ventilated disc brakes
ABS brakes	Four channel ABS brakes	Electronic parking brake	Electronic parking brake
ABS brakes	4-wheel antilock (ABS) brakes		

Brake Assistance

Hill start assist	Hill Start Assist	Brake assist system	Brake assist system
-------------------	-------------------	---------------------	---------------------

Front Suspension

Front anti-roll	Front anti-roll bar	Suspension ride type front	Independent front suspension
-----------------	---------------------	----------------------------	------------------------------

Suspension type front	Strut front suspension		
-----------------------	------------------------	--	--

Front Spring

Regular front springs	Regular front springs	Springs front	Front coil springs
-----------------------	-----------------------	---------------	--------------------

Rear Spring

Springs rear	Rear coil springs	Rear springs	Regular grade rear springs
--------------	-------------------	--------------	----------------------------

Rear Suspension

Rear anti-roll	Rear anti-roll bar	Suspension type rear	Short and long arm rear suspension
----------------	--------------------	----------------------	------------------------------------

Suspension ride type rear	Independent rear suspension		
---------------------------	-----------------------------	--	--

Steering

Steering	Electric power-assist steering system	Steering type	Rack-pinion steering
Speed sensitive steering	Speed sensitive power steering	Driver selectable steering effort	Terrain Management System with G.O.A.T. Modes driver selectable steering effort

Steering type number of wheels	2-wheel steering system		
--------------------------------	-------------------------	--	--

Exterior

Front Wheels

Front wheels diameter	17"	Front wheels width	7"
-----------------------	-----	--------------------	----

Rear Wheels

Rear wheels diameter	17"	Rear wheels width	7"
----------------------	-----	-------------------	----

Prices and content availability as shown are subject to change and should be treated as estimates only. Actual base vehicle, package and option pricing may vary from this estimate because of special local pricing, availability or pricing adjustments not reflected in the dealer's computer system. See salesperson for the most current information.

Prepared for: Mr. Mike Marotta

General Supervisor, Passaic Valley Water Commission

Prepared by: Dave Armiger

ROUTE 23 AUTOMALL | NJ COOPERATIVE PURCHASING COOPERATIVE BC BID

03/06/2026

| 24-43



2026 Bronco Sport 4dr 4x4 Big Bend (R9B)

Price Level: 630 | Quote ID: PVWCR9B

Selected Equip & Specs (cont'd)

Front And Rear Wheels

Appearance	grey	Material	aluminum
<i>Front Tires</i>			
Aspect	65	Diameter	17"
Sidewalls	BSW	Speed	H
Tread	AS	Type	P
Width	225mm		
<i>Rear Tires</i>			
Aspect	65	Diameter	17"
Sidewalls	BSW	Speed	H
Tread	AS	Type	P
Width	225mm		

Body Exterior

Exterior Features

Number of doors 4 doors

Body

Body panels Fully galvanized steel body panels with side impact beams

Convenience

Door Locks

Door locks	Power door locks with 2 stage unlocking	Fob engine controls	Intelligent Access proximity key with hands-free access and push button start
Keyfob door locks	Keyfob activated door locks	All-in-one key	All-in-one remote fob and ignition key
Auto door locks	Auto-locking doors	Tailgate control	Power tailgate/rear door lock

Cruise Control

Cruise control	Cruise control with steering wheel mounted controls	Adaptive cruise control	Adaptive Cruise Control with Stop-and-Go
----------------	---	-------------------------	--

Key Fob Controls

Keyfob cargo controls	Keyfob trunk control
-----------------------	----------------------

Rear View Mirror

Day/Night rearview mirror Day/Night rearview mirror

Exterior Mirrors

Door mirrors	Power door mirrors	Folding door mirrors	Manual folding door mirrors
Heated door mirrors	Heated driver and passenger side door mirrors		

Prices and content availability as shown are subject to change and should be treated as estimates only. Actual base vehicle, package and option pricing may vary from this estimate because of special local pricing, availability or pricing adjustments not reflected in the dealer's computer system. See salesperson for the most current information.



2026 Bronco Sport 4dr 4x4 Big Bend (R9B)

Price Level: 630 | Quote ID: PVWCR9B

Selected Equip & Specs (cont'd)

Front Side Windows

First-row windows Power first-row windows

Floor Console

Floor console Full floor console Floor console storage Covered floor console storage

Overhead Console

Overhead console Mini overhead console Overhead console storage Overhead console storage

Driver Visor

Visor driver mirror Driver visor mirror Visor illuminated driver mirror Illuminated driver visor mirror

Visor driver expandable coverage Driver visor with expandable coverage

Passenger Visor

Visor passenger mirror Passenger visor mirror Visor illuminated passenger mirror Illuminated passenger visor mirror

Visor passenger expandable coverage Passenger visor with expandable coverage

Power Outlets

12V power outlets 2 12V power outlets

Cargo Features

Cargo tie downs Cargo area tie downs Cargo light Cargo area light

Concealed cargo storage Cargo area concealed storage

Cargo Trim

Cargo floor type Carpet cargo area floor Trunk lid trim Plastic trunk lid trim

Pedals

Driver foot rest Driver foot rest

Rear Windshield

Rear window defroster Rear window defroster Rear windshield Flip-up rear windshield

Rear windshield wipers Yes rear windshield wipers

Storage

Door bins front Driver and passenger door bins Door bins rear Rear door bins

Number of beverage holders 8 beverage holders Beverage holders Front beverage holders

Beverage holders rear Rear beverage holders Glove box Standard glove box

Instrument panel storage Instrument panel bin

Windows Feature

Prices and content availability as shown are subject to change and should be treated as estimates only. Actual base vehicle, package and option pricing may vary from this estimate because of special local pricing, availability or pricing adjustments not reflected in the dealer's computer system. See salesperson for the most current information.

Prepared for: Mr. Mike Marotta

General Supervisor, Passaic Valley Water Commission

Prepared by: Dave Armiger

ROUTE 23 AUTOMALL | NJ COOPERATIVE PURCHASING COOPERATIVE BC BID

03/06/2026

| 24-43



2026 Bronco Sport 4dr 4x4 Big Bend (R9B)

Price Level: 630 | Quote ID: PVWCR9B

Selected Equip & Specs (cont'd)

One-touch down window Driver one-touch down window

Windows Rear Side

Second-row windows Power second-row windows Third-row windows Fixed third-row windows

Miscellaneous

Trip computer Trip computer PRND in IP PRND in IP
Accessory power Retained accessory power Over the air updates Over the air updates

Comfort

Climate Control

Climate control Automatic climate control Cabin air filter Cabin air filter
Voice activated climate control Voice-activated climate control Rear under seat ductsRear under seat climate control ducts
Rear console climate control ducts Rear console climate control ducts

Headliner

Headliner material Cloth headliner material Headliner coverage Full headliner coverage

Door Trim

Door panel insert Metal-look door panel insert

Floor Trim

Floor covering Full carpet floor covering Floor coverage Full floor coverage
Floor mats Carpet front floor mats

Second-Row Seat Trim

Rear seat upholstery Cloth rear seat upholstery Rear seatback upholstery Carpet rear seatback upholstery

Steering Wheel

Steering wheel material Urethane steering wheel Steering wheel telescopic Manual telescopic steering wheel
Steering wheel tilt Manual tilting steering wheel

Seats and Trim

Seat Capacity

Seating capacity 5

Front Seats

Driver seat direction Driver seat with 6-way directional controls Height adjustable driver seat Manual height adjustable driver seat

Prices and content availability as shown are subject to change and should be treated as estimates only. Actual base vehicle, package and option pricing may vary from this estimate because of special local pricing, availability or pricing adjustments not reflected in the dealer's computer system. See salesperson for the most current information.

Prepared for: Mr. Mike Marotta

General Supervisor, Passaic Valley Water Commission

Prepared by: Dave Armiger
03/06/2026

ROUTE 23 AUTOMALL | NJ COOPERATIVE PURCHASING COOPERATIVE BC BID



| 24-43

2026 Bronco Sport 4dr 4x4 Big Bend (R9B)

Price Level: 630 | Quote ID: PVWCR9B

Selected Equip & Specs (cont'd)

Driver seat fore/aft control Manual driver seat fore/aft control

Split front seats Bucket front seats

Passenger seat fore/aft control Manual passenger seat fore/aft control

Front head restraint control Manual front seat head restraint control

Reclining driver seat Manual reclining driver seat

Rear Seats

Bench seats Rear bench seat

Folding second-row seats 60-40 folding rear seats

Rear seat direction Front facing rear seat

Fore and aft seat Rear seats with manual fore and aft

Rear head restraint control Manual rear seat head restraint control

Armrests rear Rear seat center armrest

Front Seat Trim

Front seat upholstery Cloth front seat upholstery

Interior Accents

Interior accents Metal-look interior accents

Entertainment Features

Displays

Primary touchscreen display Primary touchscreen display

Primary display size 13.2 inch primary display

Radio Features

External memory SYNC 4 external memory control RDS Radio data system (RDS)

Speakers

Speakers Standard grade speakers

Audio Features

Steering mounted audio control Steering wheel mounted audio controls

Passenger seat direction Front passenger seat with 4-way directional controls

Reclining passenger seat Manual reclining passenger seat

Front head restraints Height adjustable front seat head restraints

Armrests front center Front seat center armrest

Rear seats fixed or removable Fixed rear seats

Reclining second-row rear seats Manual reclining rear seats

Rear seat folding position Fold forward rear seatback

Rear head restraints Height adjustable rear seat head restraints

Number of rear head restraints 3 rear seat head restraints

Front seatback upholstery Cloth front seatback upholstery

Number of first-row displays 2 total number of 1st row displays

Seek scan Seek scan
Internet radio capability Internet radio capability

Speakers number 6

Speed sensitive volume Speed sensitive volume

Prices and content availability as shown are subject to change and should be treated as estimates only. Actual base vehicle, package and option pricing may vary from this estimate because of special local pricing, availability or pricing adjustments not reflected in the dealer's computer system. See salesperson for the most current information.

Prepared for: Mr. Mike Marotta

General Supervisor, Passaic Valley Water Commission

Prepared by: Dave Armiger

ROUTE 23 AUTOMALL | NJ COOPERATIVE PURCHASING COOPERATIVE BC BID

03/06/2026

| 24-43



2026 Bronco Sport 4dr 4x4 Big Bend (R9B)

Price Level: 630 | Quote ID: PVWCR9B

Selected Equip & Specs (cont'd)

Voice activated audio controls	SYNC 4 voice activated audio controls	Wireless streaming streaming	Bluetooth wireless audio
--------------------------------	---------------------------------------	------------------------------	--------------------------

Lighting, Visibility and Instrumentation

Instrument Panel Trim

Panel insert	Metal-look instrument panel insert
--------------	------------------------------------

Instrumentation

Trip odometer	Trip odometer	Instrumentation display display	Digital/analog instrumentation display
---------------	---------------	---------------------------------	--

Configurable instrumentation gauges	Configurable instrumentation gauges
-------------------------------------	-------------------------------------

Instrumentation Displays

Speedometer	Redundant digital speedometer	Temperature display	Exterior temperature display
Driver information center	Driver information center	Clock	Digital clock
Compass	Compass	Eco feedback feedback display gauge	SmartGauge with EcoGuide ECO feedback display gauge

Instrumentation Gauges

Tachometer	Tachometer	Inclinometer	Inclinometer
Engine/electric motor temperature gauge	Engine/electric motor temperature gauge	Gauge cluster display size (inches)	8.00

Instrumentation Warnings

Engine temperature warning	Engine temperature warning	Oil pressure warning	Oil pressure warning
Low fuel warning	Low fuel warning	Low washer fluid warning	Low washer fluid warning
Low brake fluid warning	Low brake fluid warning	Battery charge warning	Battery charge warning
Headlights on reminder	Headlights on reminder	Key in vehicle warning	Key in vehicle warning
Bulb warning	Bulb failure warning	Door ajar warning	Door ajar warning
Trunk warning	Rear cargo ajar warning	Service interval warning	Intelligent Oil-Life Monitor service interval indicator
Low tire pressure warning	Tire specific low air pressure warning	Transmission fluid temperature warning	Transmission fluid temp warning

Glass

Tinted windows	Deep tinted windows
----------------	---------------------

Headlights

Headlights	LED low and high beam headlights	Headlight type	Projector beam headlights
Auto headlights	Autolamp auto on/off headlight control	Delay off headlights	Delay-off headlights
Auto high-beam headlights	Auto High Beam auto high-beam headlights	DRL preference setting	DRL preference setting

Prices and content availability as shown are subject to change and should be treated as estimates only. Actual base vehicle, package and option pricing may vary from this estimate because of special local pricing, availability or pricing adjustments not reflected in the dealer's computer system. See salesperson for the most current information.

Prepared for: Mr. Mike Marotta

General Supervisor, Passaic Valley Water Commission

Prepared by: Dave Armiger
03/06/2026

ROUTE 23 AUTOMALL | NJ COOPERATIVE PURCHASING COOPERATIVE BC BID



| 24-43

2026 Bronco Sport 4dr 4x4 Big Bend (R9B)

Price Level: 630 | Quote ID: PVWCR98B

Selected Equip & Specs (cont'd)

Front Windshield

Wipers Variable intermittent front windshield wipers Speed sensitive wipers Speed sensitive wipers

Interior Lighting

Illuminated entry Illuminated entry Illuminated ignition switch Illuminated ignition switch
Variable panel light Variable instrument panel light Front reading lights Front reading lights
Rear reading lights Rear reading lights

Lights

Running lights LED daytime running lights Interior courtesy lights Fade interior courtesy lights
LED brake lights LED brake lights High mount stop light High mounted center stop light

Technology and Telematics

Connectivity

Handsfree Bluetooth handsfree wireless device connectivity Smart device integration Apple CarPlay/Android Auto
Emergency SOS SYNC 4 911 Assist emergency SOS system via mobile device smart device wireless mirroring

Internet Access

Internet access 5G Modem - Ford Connectivity
Package mobile hotspot internet access

USB Ports

USB ports 4 USB ports

Safety and Security

Airbags

Front impact airbag driver Driver front impact airbag Number of airbags 7 airbags
Front impact airbag passenger Passenger front impact airbag Knee airbag Driver side knee airbag
Front side impact airbag driver Seat mounted side impact front passenger airbag
Occupancy sensor Airbag occupancy sensor Overhead airbags Safety Canopy System curtain first and second-row overhead airbags

Seatbelts

3-point seatbelt Rear seat center 3-point seatbelt Height adjustable seatbelts Front height adjustable seatbelts
Seatbelt pretensioners Front seatbelt pretensioners Seatbelt pretensioners number 2 seatbelt pretensioners

Security System

Immobilizer SecuriLock immobilizer Remote panic alarm Remote panic alarm

Prices and content availability as shown are subject to change and should be treated as estimates only. Actual base vehicle, package and option pricing may vary from this estimate because of special local pricing, availability or pricing adjustments not reflected in the dealer's computer system. See salesperson for the most current information.

Prepared for: Mr. Mike Marotta

General Supervisor, Passaic Valley Water Commission

Prepared by: Dave Armiger

ROUTE 23 AUTOMALL | NJ COOPERATIVE PURCHASING COOPERATIVE BC BID

03/06/2026

| 24-43



2026 Bronco Sport 4dr 4x4 Big Bend (R9B)

Price Level: 630 | Quote ID: PVWCR9B

Selected Equip & Specs (cont'd)

Vehicle tracker	FordPass Connect vehicle tracker	Security system	Security system
<i>Active Driving Assistance</i>			
Lane departure	Lane-Keeping System	Blind spot	BLIS (Blind Spot Information System)
Forward collision warning	Pre-Collision Assist with Automatic Emergency Braking (AEB) forward collision mitigation	Rear collision warning	Rear Cross-Traffic Braking collision mitigation
Pedestrian detection	Pre-Collision Assist with Pedestrian Detection	Driver attention monitor	Driver Alert
Evasion assist system	Evasive Steering Assist evasion assist system	Autonomous cruise control	Lane Centering hands-on cruise control
SAE Autonomy	Level 2 - partial automation SAE Autonomy		
<i>Cameras</i>			
Rear camera	Rear mounted camera		
<i>Traction Control</i>			
Electronic stability control	AdvanceTrac w/Roll Stability Control electronic stability control system with anti-rollover		
<i>Parking Sensors</i>			
Parking sensors	Rear parking sensors		
<i>Occupant Safety</i>			
Child door locks	Manual rear child safety door locks		

Prices and content availability as shown are subject to change and should be treated as estimates only. Actual base vehicle, package and option pricing may vary from this estimate because of special local pricing, availability or pricing adjustments not reflected in the dealer's computer system. See salesperson for the most current information.

Prepared for: Mr. Mike Marotta

General Supervisor, Passaic Valley Water Commission

Prepared by: Dave Armiger
03/06/2026

ROUTE 23 AUTOMALL | NJ COOPERATIVE PURCHASING COOPERATIVE BC BID
| 24-43



2026 Bronco Sport 4dr 4x4 Big Bend (R9B)

Price Level: 630 | Quote ID: PVWCR9B

Warranty

Standard Warranty

Basic Warranty

Basic warranty

36 months/36,000 miles

Powertrain Warranty

Powertrain warranty

60 months/60,000 miles

Corrosion Perforation

Corrosion perforation warranty

60 months/unlimited

Roadside Assistance Warranty

Roadside warranty

60 months/60,000 miles

Prices and content availability as shown are subject to change and should be treated as estimates only. Actual base vehicle, package and option pricing may vary from this estimate because of special local pricing, availability or pricing adjustments not reflected in the dealer's computer system. See salesperson for the most current information.

Prepared for: Mr. Mike Marotta
 General Supervisor, Passaic Valley Water Commission
 Prepared by: Dave Armiger
 03/06/2026



ROUTE 23 AUTOMALL | NJ COOPERATIVE PURCHASING COOPERATIVE BC BID
 | 24-43

2026 Bronco Sport 4dr 4x4 Big Bend (R9B)

Price Level: 630 | Quote ID: PVWCR9B

As Configured Vehicle

Code	Description	MSRP
Base Vehicle		
R9B	Base Vehicle Price (R9B)	\$31,845.00
Packages		
200A	Equipment Group 200A Standard Package <i>Includes:</i> - Engine: 1.5L EcoBoost Includes auto start-stop technology. - Transmission: 8-Speed Automatic Includes Terrain Management System with 5 G.O.A.T. Modes (normal, ECO, sport, slippery and off-road). - Tires: 225/65R17 102H All-Season BSW - Wheels: 17" Carbonized Gray Painted Aluminum High gloss. - Cloth w/Easy-to-Clean Front Bucket Seats Includes 6-way manual driver's (fore/aft, up/down, recline), 4-way manual passenger's (fore/aft with manual recline) seats and 2-way manually adjustable driver and front-passenger head restraints. - Radio: AM/FM Stereo Includes 6 speakers and speed-compensated volume. - Ford Connectivity Package (1-Year Included) Includes unlimited Wi-Fi hotspot, audio and video streaming, voice assistant and entertainment. Ford connectivity package included for one-year from warranty start date. Requires activation via Ford app with credit card authorization for auto-renewal; customer may cancel at any time. Evolving technology/cellular networks/vehicle capability may limit functionality and prevent operation of connected features. Ford may temporarily slow data speeds if such data usage reaches or exceeds 50GB within a 30-day period or due to network limitations. If a customer uses more than 50% of their data usage in a roaming country during a 60-day period, Ford may remove or limit the customer's data plan. - SiriusXM w/360L Includes a 3-month trial subscription for all new SiriusXM-equipped Ford vehicles. SiriusXM with 360L trial subscription; Service will automatically stop at the end of your trial subscription period unless you decide to continue service. Trial is non-transferable. If you do not wish to enjoy your trial, you can cancel by calling the number below. All SiriusXM services require a subscription, each sold separately by SiriusXM after the trial period. Service subject to the SiriusXM customer agreement and privacy policy, visit siriusxm.com for complete terms and how to cancel which includes online methods or calling 1-866-635-2349. Some services and features are subject to device capabilities and location availability. Satellite service not available in Alaska and Hawaii. Certain features and/or content may not be available in vehicles with SiriusXM with 360L unless an active data connection is enabled in the vehicle. Content varies by SiriusXM subscription plan. All fees, content and features are subject to change. SiriusXM and related logos are trademarks of Sirius XM Radio Inc. and its respective subsidiaries. - SYNC 4 w/Enhanced Voice Recognition Includes 13.2" center display, wireless Apple CarPlay and Android Auto compatibility, Alexa built-in, embedded apps, conversational voice command recognition, information on demand panel, over-the-air software updates, digital owner's manual and 911 Assist.	N/C
Powertrain		
99N	Engine: 1.5L EcoBoost <i>Includes auto start-stop technology.</i>	Included
448	Transmission: 8-Speed Automatic <i>Includes Terrain Management System with 5 G.O.A.T. Modes (normal, ECO, sport, slippery and off-road).</i>	Included

Prices and content availability as shown are subject to change and should be treated as estimates only. Actual base vehicle, package and option pricing may vary from this estimate because of special local pricing, availability or pricing adjustments not reflected in the dealer's computer system. See salesperson for the most current information.

Prepared for: Mr. Mike Marotta
 General Supervisor, Passaic Valley Water Commission
 Prepared by: Dave Armiger
 03/06/2026



ROUTE 23 AUTOMALL | NJ COOPERATIVE PURCHASING COOPERATIVE BC 81D
 | 24-43

2026 Bronco Sport 4dr 4x4 Big Bend (R9B)

Price Level: 630 | Quote ID: PVWCR98

As Configured Vehicle (cont'd)

Code	Description	MSRP
Wheels & Tires		
STDTR	Tires: 225/65R17 102H All-Season BSW	Included
STDWL	Wheels: 17" Carbonized Gray Painted Aluminum High gloss.	Included
Seats & Seat Trim		
Q	Cloth w/Easy-to-Clean Front Bucket Seats <i>Includes 6-way manual driver's (fore/aft, up/down, recline), 4-way manual passenger's (fore/aft with manual recline) seats and 2-way manually adjustable driver and front-passenger head restraints.</i>	Included
Other Options		
PAINT	Monotone Paint Application	STD
105WB	105.1" Wheelbase	STD
STDRD	Radio: AM/FM Stereo <i>Includes 6 speakers and speed-compensated volume.</i>	Included
	<p><i>Includes:</i></p> <ul style="list-style-type: none"> - Ford Connectivity Package (1-Year Included) <i>Includes unlimited Wi-Fi hotspot, audio and video streaming, voice assistant and entertainment. Ford connectivity package included for one-year from warranty start date. Requires activation via Ford app with credit card authorization for auto-renewal; customer may cancel at any time. Evolving technology/cellular networks/vehicle capability may limit functionality and prevent operation of connected features. Ford may temporarily slow data speeds if such data usage reaches or exceeds 50GB within a 30-day period or due to network limitations. If a customer uses more than 50% of their data usage in a roaming country during a 60-day period, Ford may remove or limit the customer's data plan.</i> - SiriusXM w/360L <i>Includes a 3-month trial subscription for all new SiriusXM-equipped Ford vehicles. SiriusXM with 360L trial subscription: Service will automatically stop at the end of your trial subscription period unless you decide to continue service. Trial is non-transferable. If you do not wish to enjoy your trial, you can cancel by calling the number below. All SiriusXM services require a subscription, each sold separately by SiriusXM after the trial period. Service subject to the SiriusXM customer agreement and privacy policy, visit siriusxm.com for complete terms and how to cancel which includes online methods or calling 1-866-635-2349. Some services and features are subject to device capabilities and location availability. Satellite service not available in Alaska and Hawaii. Certain features and/or content may not be available in vehicles with SiriusXM with 360L unless an active data connection is enabled in the vehicle. Content varies by SiriusXM subscription plan. All fees, content and features are subject to change. SiriusXM and related logos are trademarks of Sirius XM Radio Inc. and its respective subsidiaries.</i> - SYNC 4 w/Enhanced Voice Recognition <i>Includes 13.2" center display, wireless Apple CarPlay and Android Auto compatibility, Alexa built-in, embedded apps, conversational voice command recognition, information on demand panel, over-the-air software updates, digital owner's manual and 911 Assist.</i> 	
Emissions		

Prices and content availability as shown are subject to change and should be treated as estimates only. Actual base vehicle, package and option pricing may vary from this estimate because of special local pricing, availability or pricing adjustments not reflected in the dealer's computer system. See salesperson for the most current information.

Prepared for: Mr. Mike Marotta

General Supervisor, Passaic Valley Water Commission

Prepared by: Dave Armiger
03/06/2026

ROUTE 23 AUTOMALL | NJ COOPERATIVE PURCHASING COOPERATIVE BC BID
| 24-43



2026 Bronco Sport 4dr 4x4 Big Bend (R9B)

Price Level: 630 | Quote ID: PVWCR9B

As Configured Vehicle (cont'd)

Code	Description	MSRP
425	50-State Emissions System <small>Automatically added to orders from dealers located in the following California emissions states: California, Massachusetts, New York, Oregon, Pennsylvania, Vermont and Washington. Available option for dealers located in federal/non-California emissions border states for stock orders: Arizona, Connecticut, Delaware, Idaho, Maine, Maryland, Montana, New Hampshire, New Jersey, Nevada, Ohio, Rhode Island and West Virginia. Available option for dealers located in all states for retail orders. Available option for dealers located in all states for commercial/rental fleet orders. Available option for dealers located in all states for government fleet orders with ship-to addresses in California emissions states.</small>	N/C
Exterior Color		
YZ_01	Oxford White	N/C
SUBTOTAL		\$31,845.00
Destination Charge		\$1,995.00
TOTAL		\$33,840.00

Prices and content availability as shown are subject to change and should be treated as estimates only. Actual base vehicle, package and option pricing may vary from this estimate because of special local pricing, availability or pricing adjustments not reflected in the dealer's computer system. See salesperson for the most current information.

Prepared for: Mr. Mike Marotta

General Supervisor, Passaic Valley Water Commission

Prepared by: Dave Armiger

ROUTE 23 AUTOMALL | NJ COOPERATIVE PURCHASING COOPERATIVE BC BID

03/06/2026

| 24-43



2026 Bronco Sport 4dr 4x4 Big Bend (R9B)

Price Level: 630 | Quote ID: PVWCR9B

Pricing Summary - Single Vehicle

		MSRP
<i>Vehicle Pricing</i>		\$33,840.00
Subtotal		\$33,840.00
 <i>Pre-Tax Adjustments</i>		
Code	Description	MSRP
NJPA	NJ PURCHASING ALLIANCE	-\$636.90
Total		\$33,203.10

Customer Signature

Acceptance Date

Prices and content availability as shown are subject to change and should be treated as estimates only. Actual base vehicle, package and option pricing may vary from this estimate because of special local pricing, availability or pricing adjustments not reflected in the dealer's computer system. See salesperson for the most current information.

20

Prepared for: Mr. Mike Marotta

General Supervisor, Passaic Valley Water Commission

Prepared by: Dave Armiger

ROUTE 23 AUTOMALL | NJ COOPERATIVE PURCHASING COOPERATIVE BC BID

03/06/2026

| 24-43



2026 Bronco Sport 4dr 4x4 Big Bend (R9B)

Price Level: 630 | Quote ID: PVWCR9B

Pricing Summary - Multiple Vehicles

Vehicle Quantity: 2

	MSRP
<i>Vehicle Pricing</i>	\$67,680.00
Subtotal	\$67,680.00
<i>Pre-Tax Adjustments</i>	
Code	MSRP
NJPA	NJ PURCHASING ALLIANCE
	-\$1,273.80
Total	\$66,406.20

Customer Signature

Acceptance Date

Prices and content availability as shown are subject to change and should be treated as estimates only. Actual base vehicle, package and option pricing may vary from this estimate because of special local pricing, availability or pricing adjustments not reflected in the dealer's computer system. See salesperson for the most current information.

21

EXHIBIT B

OFFICE OF THE COMPTROLLER

CERTIFICATION OF AVAILABILITY OF FUNDS

It is hereby certified that subject to Commission approval of future Budgets, with respect to multi-budget year contracts, there are or will be sufficient available funds for expenditures to be incurred as a result of any contract or commitment to be entered into by Passaic Valley Water Commission as follows:

Description of Project or Contract: Procure "Two 2026 Ford Sport 4 Door 4x4 Big Bend Trucks" through the NJ Cooperative Purchasing Agreement, Contract BC Bid 24-43
Route 23 Automall

Amount of Project or Contract: \$66,406.20

1. Acct: #- 001-0901-419-95-04
CAPITAL – VEHICLES
2. Specific Appropriation to which expenditures will be charged:
CAPITAL 2026

Comments: Cost per vehicle: \$33,203.91 for a total of \$66,406.20

Date of Certification: March 25, 2026

Certified: \$66,406.20

Yitzhak Weiss
Comptroller and Chief Financial Officer

YW:lb

RESOLUTION NO. 26-055

PASSAIC VALLEY WATER COMMISSION

**RESOLUTION FOR BUDGET AMENDMENT, CHANGE ORDER NO. 2
FOR CONTRACT NO. 25-V-01 ENTITLED "FURNISH AND DELIVER
THICKENING AID POLYMER"**

DATE OF ADOPTION: MARCH 25, 2026

Introduced by Commissioner: **RON VAN RENSALIER**

Seconded by Commissioner: **RUBY N. COTTON**

WHEREAS, PVWC awarded Contract No. 25-V-01 entitled "Furnish and Deliver Thickening Aid Polymer (the "Contract") to Polydyne, Inc., of Riceboro, Georgia at PVWC's Commission Meeting on February 26, 2025, for a period one-year in the amount \$55,200.00 under Resolution No. 25-018; and

WHEREAS, PVWC approved Change Order No. 1 on February 25, 2026, by way of Resolution No. 26-026 to cover the cost of 6 additional totes of chemical that were required for operations; and

WHEREAS, Proposed Change Order No. 2 is required to pay for additional quantities of thickening aid polymer that was required due to the surge in use due to continued upset to the Little Falls Water Treatment System, with a total increase of five (5) totes at a cost of \$2,760.00 per tote, which brings the total adjusted Contract Price up to \$85,560.00. **Exhibit A** is a memorandum from the Water Superintendent, describing the conditions that led to the need for an increase in chemical; and

WHEREAS, PVWC's Chief Financial Officer has certified, with respect hereto, that funds are currently available for said purpose and a copy of the said certification is attached hereto and made a part hereof as **Exhibit B**.

NOW, THEREFORE, BE IT RESOLVED, by Passaic Valley Water Commission, in the County of Passaic, New Jersey:

1. That PVWC hereby authorizes and awards Change Order No. 2 to the terms as set forth hereinabove; and
2. That an appropriate official of PVWC, on behalf of PVWC, is hereby authorized and directed to execute this Change Order as set forth hereinabove and implement the terms of this Change Order in accordance with this Resolution and the submissions provided in connection herewith, and the Secretary of PVWC to attest to this Change Order No. 2 and such other officers, employees and officials of PVWC are hereby authorized to perform such acts and execute such documents as are necessary to implement the terms and intentions of this Resolution; and
3. That this matter shall be advertised as required by New Jersey law, in accordance with an appropriate form of notice, and a copy of this Resolution shall be placed on file and made available for public inspection at the office of the Administrative Secretary of Passaic Valley Water Commission.

RECORD OF COMMISSION VOTE ON FINAL PASSAGE

	AYE	NAY	ABSTAIN	ABSENT
COTTON, R.	<u>X</u>	---	---	---
DEPADUA, C.	<u>X</u>	---	---	---
FRIEND, G.	<u>X</u>	---	---	---
LEVINE, J.	<u>X</u>	---	---	---
SANCHEZ, R.	<u>X</u>	---	---	---
VAN RENSA LIER, R.	<u>X</u>	---	---	---
RIZZI, D.	<u>X</u>	---	---	---

Adopted at a meeting of Passaic Valley Water Commission.

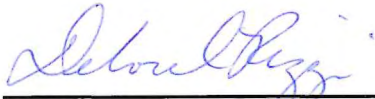

DEBORAH RIZZI
President



RUBY N. COTTON
Secretary

This Resolution, when adopted, must remain in the custody of the Administrative Secretary.

CERTIFICATION

I, LOUIS AMODIO, Administrative Secretary of the Passaic Valley Water Commission in the County of Passaic, and the State of New Jersey do hereby certify that the foregoing Resolution is a true copy thereof of the foregoing Resolution duly passed and adopted by a majority of a legal quorum of the full membership of the Passaic Valley Water Commission at its duly noticed and convened meeting of the said Commission on March 25, 2026.

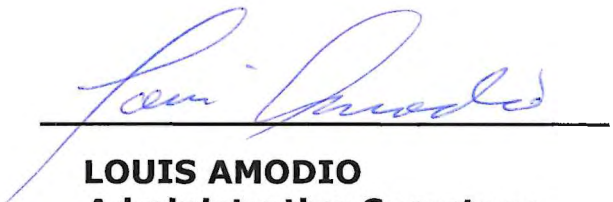

LOUIS AMODIO
Administrative Secretary

EXHIBIT A



Executive Director
James Mueller, PE

Commissioners
Deborah Rizzi, President, Clifton
Carmen DePadua, Vice President, Paterson
Ronald Van Rensalier, Treasurer, Passaic
Ruby N. Cotton, Secretary, Paterson
Gerald Friend, Commissioner, Clifton
Jeffrey Levine, Commissioner, Paterson
Rigo Sanchez, Commissioner, Passaic

To: Commissioners

From: Wendy Simone, Water Superintendent, Lab Manager

Cc: Lisa Bresemann, Purchasing Agent

Re: Clarifloc A-210P

All 3 chemicals (A-210P), (A333P), (Residual Trucks) are interrelated due to the following problems that are occurring within the treatment plant.

We are experiencing different water quality due to Wanaque South pumping (168mgd) the Pompton River and much colder temperatures. Higher organics which lead to a much higher ferric dose throughout the winter, normally the average dose is at 30ppm and we are averaging 50ppm. We are also experiencing much higher flows, the average is 52mgd for winter months and we are pumping close to 70mgd. This increases the amount of sludge produced. The sludge mound in sludge tank 3 is growing which limits the capacity of liquid sludge that can be maintained within the tank (tank size is getting smaller each year). More trucks are needed before the sludge reaches the overflow much faster. Our sludge pumps are leaking water into tank 3 which also limits our capacity within the tank. Many Thickener upsets within the last few months which increases the height of tank 3 and more residual trucks are needed to maintain the level in tank 3. There are many factors contributing to this increase in chemicals and trucks and it is hard to know how to compensate for the chemicals / loads needed in advance.

Thank you,

Wendy Simone

PASSAIC VALLEY WATER COMMISSION
1525 MAIN AVENUE • P.O. BOX 230
CLIFTON, NEW JERSEY 07011
(973) 340-4300

EXHIBIT B

OFFICE OF THE COMPTROLLER

CERTIFICATION OF AVAILABILITY OF FUNDS

It is hereby certified that subject to Commission approval of future Budgets, with respect to multi-budget year contracts, there are or will be sufficient available funds for expenditures to be incurred as a result of any contract or commitment to be entered into by Passaic Valley Water Commission as follows:

Description of Project or Contract: Contract No. 25-V-01 – Change Order No. 2
Entitled “Furnish and Deliver Thickening Aid
Polymer”
Polydyne, Inc.

Amount of Project or Contract:

Initial Amount: \$55,200.00
Change Order No. 1 Increase to \$71,760.00
Change Order No. 2 Increase of \$13,800.00 to \$85,560.00

1. Acct: # 001-1002-421-70-11
BUDGET/CHEMICALS
2. Specific Appropriation to which expenditures will be charged:
BUDGET: 2026

Other comments: Change Order No.2 Increase of \$13,800.00
for a new Not to Exceed of \$85,560.00 (Total Increase of 55%)

Date of Certification: March 25, 2026 Amount Certified: \$85,560.00

Yitzchak Weiss
Comptroller and Chief Financial Officer

YW:lb

RESOLUTION NO. 26-056

PASSAIC VALLEY WATER COMMISSION

**RESOLUTION FOR BUDGET AMENDMENT, CHANGE ORDER NO. 1
FOR CONTRACT NO. 25-V-05 ENTITLED "FURNISH AND DELIVER
FLOCCULATION AID DRY POLYMER"**

DATE OF ADOPTION: MARCH 25, 2026

Introduced by Commissioner: **RON VAN RENSALIER**

Seconded by Commissioner: **RUBY N. COTTON**

WHEREAS, PVWC awarded Contract No. 25-V-05 entitled "Furnish and Deliver Flocculation Aid Dry Polymer (the "Contract") to Polydyne, Inc., of Riceboro, Georgia at PVWC's Commission Meeting on April 23, 2025, for a period one-year in the amount \$93,000.00 under Resolution No. 25-055; and

WHEREAS, Proposed Change Order No. 1 is required to pay for additional quantities of flocculation aid dry polymer that was required due to the surge in use due to a major upset to the Little Falls Water Treatment System, with a total increase of 6,000 pounds at a cost of \$1.55 per pound for a shortfall of \$9,300.00. The addition of \$9,300.00 to the contract brings the total adjusted Contract Price up to \$102,300.00. **Exhibit A** is a memorandum from the Water Superintendent dated, describing the conditions that led to the need for an increase in chemical; and

WHEREAS, PVWC's Chief Financial Officer has certified, with respect hereto, that funds are currently available for said purpose and a copy of the said certification is attached hereto and made a part hereof as **Exhibit B**.

NOW, THEREFORE, BE IT RESOLVED, by Passaic Valley Water Commission, in the County of Passaic, New Jersey:

1. That PVWC hereby authorizes and awards Change Order No. 1 to the terms as set forth hereinabove; and

2. That an appropriate official of PVWC, on behalf of PVWC, is hereby authorized and directed to execute this Change Order as set forth hereinabove and implement the terms of this Change Order in accordance with this Resolution and the submissions provided in connection herewith, and the Secretary of PVWC to attest to this Change Order No. 1 and such other officers, employees and officials of PVWC are hereby authorized to perform such acts and execute such documents as are necessary to implement the terms and intentions of this Resolution; and
3. That this matter shall be advertised as required by New Jersey law, in accordance with an appropriate form of notice, and a copy of this Resolution shall be placed on file and made available for public inspection at the office of the Administrative Secretary of Passaic Valley Water Commission.

RECORD OF COMMISSION VOTE ON FINAL PASSAGE

	AYE	NAY	ABSTAIN	ABSENT
COTTON, R.	<u>X</u>	---	---	---
DEPADUA, C.	<u>X</u>	---	---	---
FRIEND, G.	<u>X</u>	---	---	---
LEVINE, J.	<u>X</u>	---	---	---
SANCHEZ, R.	<u>X</u>	---	---	---
VAN RENSA LIER, R.	<u>X</u>	---	---	---
RIZZI, D.	<u>X</u>	---	---	---

Adopted at a meeting of Passaic Valley Water Commission.



DEBORAH RIZZI
President



RUBY N. COTTON
Secretary

This Resolution, when adopted, must remain in the custody of the Administrative Secretary.

CERTIFICATION

I, LOUIS AMODIO, Administrative Secretary of the Passaic Valley Water Commission in the County of Passaic, and the State of New Jersey do hereby certify that the foregoing Resolution is a true copy thereof of the foregoing Resolution duly passed and adopted by a majority of a legal quorum of the full membership of the Passaic Valley Water Commission at its duly noticed and convened meeting of the said Commission on March 25, 2026.

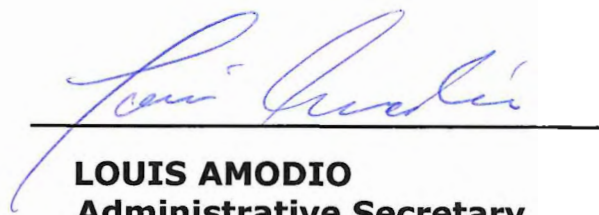

LOUIS AMODIO
Administrative Secretary

EXHIBIT A



Executive Director
James Mueller, PE

Commissioners
Deborah Rizzi, President, Clifton
Carmen DePadua, Vice President, Paterson
Ronald Van Rensalier, Treasurer, Passaic
Ruby N. Cotton, Secretary, Paterson
Gerald Friend, Commissioner, Clifton
Jeffrey Levine, Commissioner, Paterson
Rigo Sanchez, Commissioner, Passaic

To: Commissioners

From: Wendy Simone, Water Superintendent, Lab Manager

Cc: Lisa Bresemann, Purchasing Agent

Re: Clarifloc A333P

All 3 chemicals (A-210P), (A333P), (Residual Trucks) are interrelated due to the following problems that are occurring within the treatment plant.

We are experiencing different water quality due to Wanaque South pumping (168mgd) the Pompton River and much colder temperatures. Higher organics which lead to a much higher ferric dose throughout the winter, normally the average dose is at 30ppm and we are averaging 50ppm. We are also experiencing much higher flows, the average is 52mgd for winter months and we are pumping close to 70mgd. This increases the amount of sludge produced. The sludge mound in sludge tank 3 is growing which limits the capacity of liquid sludge that can be maintained within the tank (tank size is getting smaller each year). More trucks are needed before the sludge reaches the overflow much faster. Our sludge pumps are leaking water into tank 3 which also limits our capacity within the tank. Many Thickener upsets within the last few months which increases the height of tank 3 and more residual trucks are needed to maintain the level in tank 3. There are many factors contributing to this increase in chemicals and trucks and it is hard to know how to compensate for the chemicals / loads needed in advance.

Thank you,

Wendy Simone

PASSAIC VALLEY WATER COMMISSION
1525 MAIN AVENUE • P.O. BOX 230
CLIFTON, NEW JERSEY 07011
(973) 340-4300

EXHIBIT B

OFFICE OF THE COMPTROLLER

CERTIFICATION OF AVAILABILITY OF FUNDS

It is hereby certified that subject to Commission approval of future Budgets, with respect to multi-budget year contracts, there are or will be sufficient available funds for expenditures to be incurred as a result of any contract or commitment to be entered into by Passaic Valley Water Commission as follows:

Description of Project or Contract: Contract No. 25-V-05 – Change Order No. 1
Entitled “Furnish and Deliver Flocculation Aid Dry
Polymer”
Polydyne

Amount of Project or Contract:

Initial Amount: \$93,000.00
Change Order No. 1 Increase of \$9,300.00
Change Order No. 1 Not to Exceed: \$102,300.00

1. Acct: # 001-1002-421-70-11
BUDGET/CHEMICALS
2. Specific Appropriation to which expenditures will be charged:
BUDGET: 2026

Other comments: Change Order No. 1 Increase of \$9,300.00
For a new Not to Exceed of \$102,300.00

Date of Certification: March 25, 2026 Amount Certified: \$102,300.00

Yitzhak Weiss
Comptroller and Chief Financial Officer

YW:lb

RESOLUTION NO. 26-057

PASSAIC VALLEY WATER COMMISSION

RESOLUTION RESCINDING PVWC RESOLUTION 26-018

DATE OF ADOPTION: MARCH 25, 2026

Introduced by Commissioner: **RON VAN RENSA LIER**

Seconded by Commissioner: **RUBY N. COTTON**

WHEREAS, on January 21, 2026, the Board approved Resolution No. 26-018, attached hereto as Exhibit A, authorizing the repair of a 4-State 1000 HP Booster Pump located at the Morris County Pump House in the amount of \$153,128.00; and

WHEREAS, since the approval of Resolution No. 26-018, it was determined that the cost of a new pump, utilizing a purchasing cooperative was less than the cost of the repairs; and

WHEREAS, for cost efficiency it is requested that we rescind Resolution No. 26-018; and

NOW, THEREFORE, BE IT RESOLVED, by Passaic Valley Water Commission, in the County of Passaic, New Jersey.

1. That Resolution No. 26-018 is hereby rescinded; and
2. That the appropriate officers and employees of PVWC are hereby authorized to perform such acts and execute such documents as are necessary to implement the terms and intentions of this Resolution.
3. That this matter shall be advertised as required by New Jersey law, in accordance with an appropriate form of notice, and a copy of this Resolution shall be placed on file and made available for public inspection at the office of the Administrative Secretary of Passaic Valley Water Commission.

RECORD OF COMMISSION VOTE ON FINAL PASSAGE

	AYE	NAY	ABSTAIN	ABSENT
COTTON, R.	<u>X</u>	—	—	—
DEPADUA, C.	<u>X</u>	—	—	—
FRIEND, G.	<u>X</u>	—	—	—
LEVINE, J.	<u>X</u>	—	—	—
SANCHEZ, R.	<u>X</u>	—	—	—
VAN RENSA LIER, R.	<u>X</u>	—	—	—
RIZZI, D.	<u>X</u>	—	—	—

Adopted at a meeting of Passaic Valley Water Commission.



DEBORAH RIZZI
President



RUBY N. COTTON
Secretary

This Resolution, when adopted, must remain in the custody of the Administrative Secretary.

CERTIFICATION

I, LOUIS AMODIO, Administrative Secretary of the Passaic Valley Water Commission in the County of Passaic, and the State of New Jersey do hereby certify that the foregoing Resolution is a true copy thereof of the foregoing Resolution duly passed and adopted by a majority of a legal quorum of the full membership of the Passaic Valley Water Commission at its duly noticed and convened meeting of the said Commission on March 25, 2026.

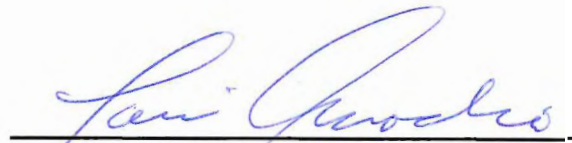

LOUIS AMODIO
Administrative Secretary

EXHIBIT A

RESOLUTION NO. 26-018

PASSAIC VALLEY WATER COMMISSION

RESOLUTION AUTHORIZING THE REPAIR OF A 4-STAGE 1,000 HP BOOSTER PUMP LOCATED AT THE MORRIS COUNTY PUMP HOUSE UTILIZING THE NEW JERSEY COOPERATIVE CONTRACT #B454-17

DATE OF ADOPTION: JANUARY 21, 2026

Introduced by Commissioner: **RIGO SANCHEZ**

Seconded by Commissioner: **RUBY N. COTTON**

WHEREAS, it was discovered that the impellers in a 4-Stage 1,000 HP Boster Pump located in the Morris County Pump Station were damaged and inoperable. This pump serves the Morris County Pump line and is crucial to our operations providing 8 million gallons per day to its customers; and

WHEREAS, Chief Operating Officer Michael Marotta prepared a Memorandum dated January 20, 2026 (the "Memorandum") describing the immediate need for repair of the pump and impellers and the costs associated with these repairs (See **Exhibit A**); and

WHEREAS, A.C. Schultes, Inc. originally estimated the cost of the repairs to be \$51,500 and we issued a purchase order no. 235648, however, after inspection more damage was discovered for an additional cost of \$153,128.00 for a total of \$204,628.00. The pump and impellers are currently disassembled and in need of immediate repair. A copy of the estimate from A.C. Shultes is attached hereto as **Exhibit B**; and

WHEREAS, in the opinion of the Supervising Engineer and the Executive Director, the necessity of replacing this broken pump constitutes an emergency affecting the immediate health, safety or welfare of the public, and required an immediate performance of services and procurement of necessary goods and services as a result of the emergency; and

WHEREAS, it was necessary, in accordance with N.J.S.A. 40A:11-6, to proceed with the performance of services and procurement of necessary goods and materials as necessary to perform all recovery and repairs, and a

purchase order was issued without public advertisement for bids pursuant to the above Statute; and

WHEREAS, in accordance with N.J.S.A. 40A:11-12, PVWC may purchase goods or services under contracts entered into on behalf of the State by the Division of Purchase and Property in the Department of the Treasury; and

WHEREAS, PVWC has elected to procure the above-referenced services from A.C. Schultze, Inc. of Woodbury Heights, New Jersey (the "Awardee") utilizing the New Jersey Cooperative (the "Co-op"), Contract #B454-17, in the amount of \$153,128.00, as described in **Exhibit B**; and

WHEREAS, the Chief Engineer's formal certification signed and dated January 20, 2026 (the "Formal Certification") of the emergency (and which has been filed by the Director of Engineering and endorsed by the Executive Director in support of this resolution) is attached hereto and made a part hereof as **Exhibit C**; and

WHEREAS, PVWC's Chief Financial Officer has certified, with respect hereto, that funds are currently available for said purpose and a copy of the said certification is attached hereto and made a part hereof as **Exhibit D**.

NOW, THEREFORE, BE IT RESOLVED that in accordance with the provisions of N.J.S.A. 40A:11-6, Passaic Valley Water Commission, in the County of Passaic, New Jersey;

1. Authorizes and/or ratifies the action taken by the Engineer Department and the Executive Director, based on the documentation incorporated herein, confirming the existence of an emergency within the meaning and contemplation of the Local Public Contracts Law; and
2. Hereby approve and/or ratifies actions taken by officers and employees of the Passaic Valley Water Commission to implement the terms and intentions of this Resolution, and hereby authorizes the appropriate officers and employees of the Passaic Valley Water Commission to perform such additional acts and execute such

additional documents as are necessary to implement the terms and intention of this Resolution; and

3. That the Purchasing Cooperative for procurement of the above-referenced services is hereby awarded to the Awardee as set forth hereinabove; and
4. That this matter shall be advertised as required by New Jersey law, in accordance with an appropriate form of notice, and a copy of this Resolution shall be placed on file and made available for public inspection at the office of the Administrative Secretary of Passaic Valley Water Commission.

RECORD OF COMMISSION VOTE ON FINAL PASSAGE

	AYE	NAY	ABSTAIN	ABSENT
COTTON, R.	<u>X</u>	—	—	—
DEPADUA, C.	<u>X</u>	—	—	—
FRIEND, G.	<u>X</u>	—	—	—
LEVINE, J.	<u>X</u>	—	—	—
SANCHEZ, R.	<u>X</u>	—	—	—
VAN RENSALIER, R.	<u>X</u>	—	—	—
RIZZI, D.	<u>X</u>	—	—	—

Adopted at a meeting of Passaic Valley Water Commission.



DEBORAH RIZZI
President



RUBY N. COTTON
Secretary

This Resolution, when adopted, must remain in the custody of the Administrative Secretary.

CERTIFICATION

I, LOUIS AMODIO, Administrative Secretary of the Passaic Valley Water Commission in the County of Passaic, and the State of New Jersey do hereby certify that the foregoing Resolution is a true copy thereof of the foregoing Resolution duly passed and adopted by a majority of a legal quorum of the full membership of the Passaic Valley Water Commission at its duly noticed and convened meeting of the said Commission on January 21, 2026.



LOUIS AMODIO
Administrative Secretary

EXHIBIT A

5

8



Executive Director
James Mueller, PE

Commissioners
Rigo Sanchez, President, Passaic
Gerald Friend, Vice President, Clifton
Carmen DePadua, Treasurer, Paterson
Ruby N. Cotton, Secretary, Paterson
Jeffrey Levine, Commissioner, Paterson
Deborah Rizzi, Commissioner, Clifton
Ronald Van Renssaler, Commissioner, Passaic

MEMORANDUM

To: Lisa Bresemann
From: Michael Marotta
Date: January 20, 2026
Subject: Repair Assessment for 4-Stage Pump 1000 HP Booster Pump/North Jersey Cooperative Contract #B454-17

Following the recent dispatch of the 4-stage pump for repair, the service provider has completed their inspection and determined that all four impellers require comprehensive repair. The details and total estimated cost for these repairs are below.

- > Rework existing 20" - 4 stage bowl assembly, including:
 - o Replace (5) bronze bowl bearings
 - o True (4) impeller wear rings
 - o Install (4) new bronze bowl wear rings
 - o Furnish (1) new 416SS pump shaft
 - o Epoxy pump exterior
- > Reassemble unit complete
- > Deliver back to Passaic Valley Water Commission job site

Original Repair cost per Purchase Order #235648: \$51,500.00
 Additional cost to apply (2) coats of Belzona 1341 NSF to all (4) impellers: \$8,000.00
 Additional cost to replace (4) impellers with new: @ \$36,282/each \$145,128.00
 Total added cost of Additional repair: **\$153,128.00**

Morris County Pump 1 does approximately 8 million gallons per day and generates approximately \$1,152,000.00 per year in annual revenue. The Morris County Pump Station located in LPWTP serves our wholesale customer which include NJ American Water, North Caldwell, West Caldwell, Fairfield, Verona and Southeast Morris Water.

There are four (4) vertical pumps located in the Morris County Connection Pump Station at the Commission's Little Falls Plant. They are numbered MCC Pump-1 through MCC Pump-3 and Transfer Pump-3 starting with No. 1 located closest to the door.

PASSAIC VALLEY WATER COMMISSION
1525 MAIN AVENUE • P.O. BOX 230
CLIFTON, NEW JERSEY 07011
(973) 340-4300

Vertical Pumps Nos. MCC Pump-1, 2, and 3 are Johnston Pump Model Number 20CC - 4 Stage pumps capable of delivering 5787 GPM at 558 Ft of Head. Each pump is driven by a 1,000 HP electric motor.

Thank you,



Michael Marotta

Chief Operating Officer

PASSAIC VALLEY WATER COMMISSION
1525 MAIN AVENUE • P.O. BOX 230
CLIFTON, NEW JERSEY 07011
(973) 340-4300

EXHIBIT B

8

11



664 S. Evergreen Ave.
Woodbury Heights, NJ 08097
24 Hour Service
(856) 845-5656 Office
ausiv@acschultes.com
www.acschultes.com

January 15, 2026

Passaic Valley Water Commission
1525 Main Street
Clifton, NJ 07011

Attention: Mike Nigro
Email: MNigro@pwwc.com

Reference: 1000 HP Booster Pump – PO #235648
ACS Job #P31597-18

Dear Sir:

A.C. Schultes, Inc. has disassembled and inspected the above referenced pump we recently picked up from your facility. With the exception of the pump impellers, the unit was in fair condition. A complete overview of the necessary work required to return the pump to proper operation is as follows:

- Pick up pump at Passaic Valley Water Commission job site
- Disassemble and inspect
- Sandblast and epoxy coat interior and exterior of 20" discharge head
- Replace 442-26 Chesterton split mechanical seal
- Install new bronze stuffing box bearing
- Sandblast and epoxy coat 20" x 58 1/4" flanged top column with built in bracket
- Sandblast and epoxy coat (1) 20" x 70" flanged column with built in bracket
- Sandblast and epoxy coat (1) 20" x 16" x 70" flanged column with built in bracket
- Replace (3) rubbers in column brackets
- Replace 2-11/16" 416SS shafting with couplings
- Replace all hardware with new stainless steel
- Rework existing 20" - 4 stage bowl assembly, including:
 - Replace (5) bronze bowl bearings
 - True (4) impeller wear rings
 - Install (4) new bronze bowl wear rings
 - Furnish (1) new 416SS pump shaft
 - Epoxy pump exterior
- Reassemble unit complete
- Deliver back to Passaic Valley Water Commission job site

MOTOR & PUMP SALES & SERVICE • WELLS • WATER WASTEWATER SYSTEM CONSTRUCTION & MAINTENANCE

1000 HP Booster Pump – PO #235648
ACS Job #P31597-18
Page 2

Repair cost as detailed above: \$42,860.00
Additional cost to apply (2) coats of Belzona 1341 NSF to all (4) impellers: \$8,000.00
Additional cost to replace (4) impellers with new: @ \$36,282/each \$145,128.00

Pricing is based on North Jersey Cooperative Contract #8454-17.

Please note we did not receive a coupling for the motor or the vortex suppressor.

Please contact this office and let us know how you would like us to proceed or if you have any additional questions regarding this project.

Sincerely,

A.C. SCHULTES, INC.

Peter W. Schultes

Peter W. Schultes, P.E.
Project Manager

PWS/dk/j: JOB #/ P31597-18/011526

EXHIBIT C

11

14

**Certification of Patrick Porcero, PE,
Director of Engineering
Passaic Valley Water Commission**

I, Patrick Porcero, PE certify to the following statements:

I am the Director of Engineering for the Passaic Valley Water Commission (PVWC). I make this Certification in support of the use of emergency procurement procedures for repair services related to the 4-Stage 1,000 HP Booster Pump under North Jersey Cooperative Contract #B454-17 to A.C. Schuttas, Inc. of Woodbury Heights, New Jersey.

Following the recent dispatch of MCC Pump No. 1 for repair, the service provider completed an inspection and determined that all four impellers require comprehensive repair. The scope of work includes rebuilding and reassembling the existing 20-inch - 4 stage bowl assembly, bowl bearings, impeller wear rings, bowl wear rings, raw pump shaft, epoxy pump exterior and replacement of all impellers. The original repair cost per Purchase Order #236648 was \$61,500.00. The additional cost for these repairs is \$163,128.00, bringing the total estimated repair cost to \$204,628.00.

Similar maintenance and inspection will be required for MCC Pumps No. 2 and 3, as well as Transfer Pump No. 3. Work will be scheduled later in 2028 to minimize impacts to wholesale customers following the repair of MCC Pump No. 1.

Emergency procurement was necessary under N.J.S.A. § 40A:11-6 to protect public health, safety, and ensure uninterrupted water service. A formal bidding process would have delayed repairs and exacerbated the risk of service disruption.

Patrick Porcero

Date: 1/20/2026

Patrick Porcero, PE
Director of Engineering
Passaic Valley Water Commission

EXHIBIT D

13

16

OFFICE OF THE COMPTROLLER

CERTIFICATION OF AVAILABILITY OF FUNDS

It is hereby certified that subject to Commission approval of future Budgets, with respect to multi-budget year contracts, there are or will be sufficient available funds for expenditures to be incurred as a result of any contract or commitment to be entered into by Passaic Valley Water Commission as follows:

Description of Project or Contract: Procure Repairs Services for of 4-State 1,000 HP
Booster Pump Located at the Morris County Pump
House Utilizing the North Jersey Cooperative
Contract #B454-17
A.C. Shultes, Inc.

Amount of Project or Contract: \$204,628.00

1. Acct: # 001-0901-419-95-37
PUMP STATION IMPROVEMENT-REMOTE
2. Specific Appropriation to which expenditures will be charged:
CAPITAL: 2026

Other comments:

Date of Certification: January 21, 2026 Amount Certified: \$204,628.00

Yitzchak Weiss
Comptroller and Chief Financial Officer

YW:lb